

RTMe - Rope Tension Meter

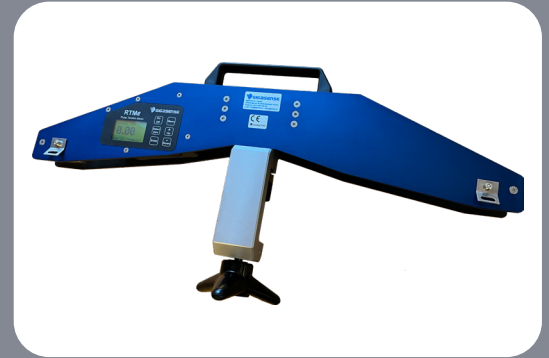

Foto: Teracon



The RTMe can be used in applications where accurate measurement in pre loaded wire ropes is required.

Typical applications can be guy wires, suspension ropes, catenary ropes etc.

The RTMe is applied directly to the rope and the measured tension value is presented in the display.

This is an updated version that replaces RTM-D. RTMe has many advantages, such as larger display, possibility of saving up to 20 different ropes, save multipoint measured values, easily toggle between readout in kN, tonne, lbs, DaN, USt and more.



RTMe Rope Tension Meter

Range of application

The RTMe was designed to swiftly and accurately measure the tension in fixed, stationary ropes or cables i.e. guy wires for masts and/or towers or other guyed constructions. The RTMe will also be very useful in determining the tension in overhead suspension ropes for railway catenaries.

The RTMe can be used to measure tension forces up to 20 metric ton and for wire ropes with a diameter up to 38 mm, up to 20 different wire rope dimensions/types can be stored in the memory.

Function

The RTMe is very simple and handy to use. Attach the RTMe to the rope and tighten the tightening screw, read the measured value directly in the display.



Multipoint measuring – easy to store up to six values for quick overview.

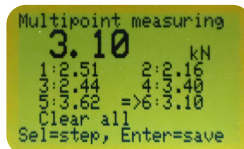

Easily toggle between readout in kN, tonne, lbs, DaN or USt.

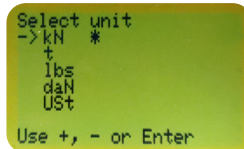

Safety

Can temporarily be overloaded with 100% of its nominal capacity without affecting the accuracy.

The RTMe is delivered in a robust and light weight transport case (760 x 400 x 170 mm) for easy handling and protection of the instrument.

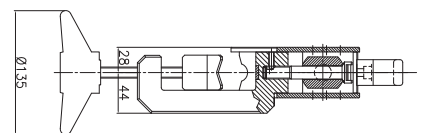
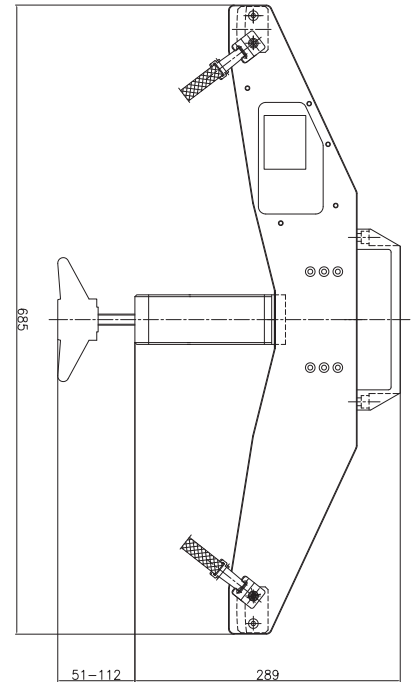

Technical Data

Capacity, Measurement range

5 ton
20 ton

Rope diameters

From 6 mm up to 38 mm.

Numbers of ropes to be stored
Up to 20 (factory programmed).

Inaccuracy

(dependent on wire rope type and characteristics)
Up to maximum $\pm 2\%$ for steel ropes and $\pm 6\%$ for copper ropes.

Display

Simple digital reading of measured values in LCD screen.

Battery

Rechargeable 1-cell lithium-ion battery, 3.7 V 850 mAh.

Operating time

60 hours at full charge.

Material

Corrosion and weather resistant, side plates of anodised aluminium.

Dimension

135x 380 x 685 mm.

Weight

6 kg.

Temperature range

-20 to +60 degrees Centigrade.

Protection class

IP 65

CHECKLINE
ELECTROMATIC EQUIPMENT

175 Vincent Ave., Lynbrook, NY 11563
web: checkline.com • tel: 516-295-4300