



## Features and benefits:

- Rounded edges to cheek plates maintain low rope abrasion when rope is fed 'unfair'
  - Upper sheave opens via a threaded locking axle for added security
  - Thrust surfaces increase tolerance to external loading of spindle and anchor pin
  - Lightweight attachment sling facilitates hauling of block, sling and rope to the climber and helps with handling, in tree stowage and workshop storage
  - Direct connection to cordage, the anchor slings helps ensure correct neighbour component compatibility
  - 100m or 328ft Bluetooth range range enabling operator to stand at safe distance
  - No easily broken external antennae
  - High waterproof resistance to IP67 or NEMA6 for all weather use
  - Massive battery life of 1200 hrs operational time
  - Handheld display or data logging software options for all applications
- 
- Supplied with a free HHP App for iOS and Android

**The safest choice for the working Arborist. Manufactured in partnership with DMM, the Impact Block has been designed to deliver the best performance in terms of alignment, resistance and appeal.**

The aesthetic curves of the Impact Block combine beauty, strength and durability to ensure a rope-friendly surface.

Coupled with wireless dynamic load monitoring electronics, and strain gauge technology from Straightpoint, it provides real-time data to either the handheld controller, or logging via their INSIGHT software to a tablet or laptop. It is easy to see why this is one of the most sought-after products in the industry.

During development, the Straightpoint Impact Block has gone through a thorough dynamic and static validation testing regime.

The end result is a highly functional product with an impressive strength to weight ratio.

## Applications:

- Tree care – dismantling ops and speed lines
- Forestry
- Winching operations
- Rescue
- Rigging
- Entertainment industry

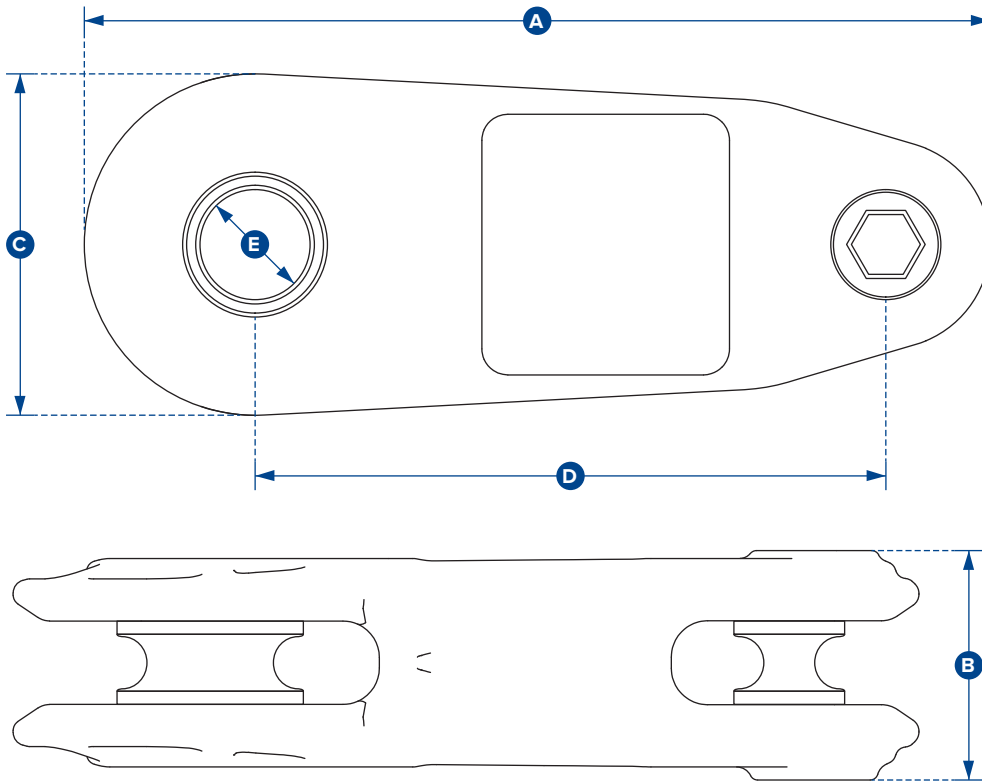

Part Numbers	
SP	WIB6T
Crosby	2789150
Capacity	60kN
Resolution	0.1kN
Units	kN
Weight	6kg
	13.2lb
Safety Factor	5:1
Battery Type	4 x AA Alkaline
Battery Life	1200 hours continuous (500hrs if Bluetooth)
Operating Temp	-10°C to +50°C or 14°F to 122°F
Accuracy	±0.1% of full scale
Frequency	2.4 GHz
System Range	100 metres or 328 feet
Data Rate	50Hz - up to 200Hz can be ordered for dynamic load monitoring applications
Protection	IP67 or NEMA6
Max Rope Ø	20mm
	0.75"
Dimension A	348
	13.7"
Dimension B	89
	3.5"
Dimension C	131
	5.16"
Dimension D	242
	9.53"
Dimension ØE	27
	1.06"