

# CableSafe

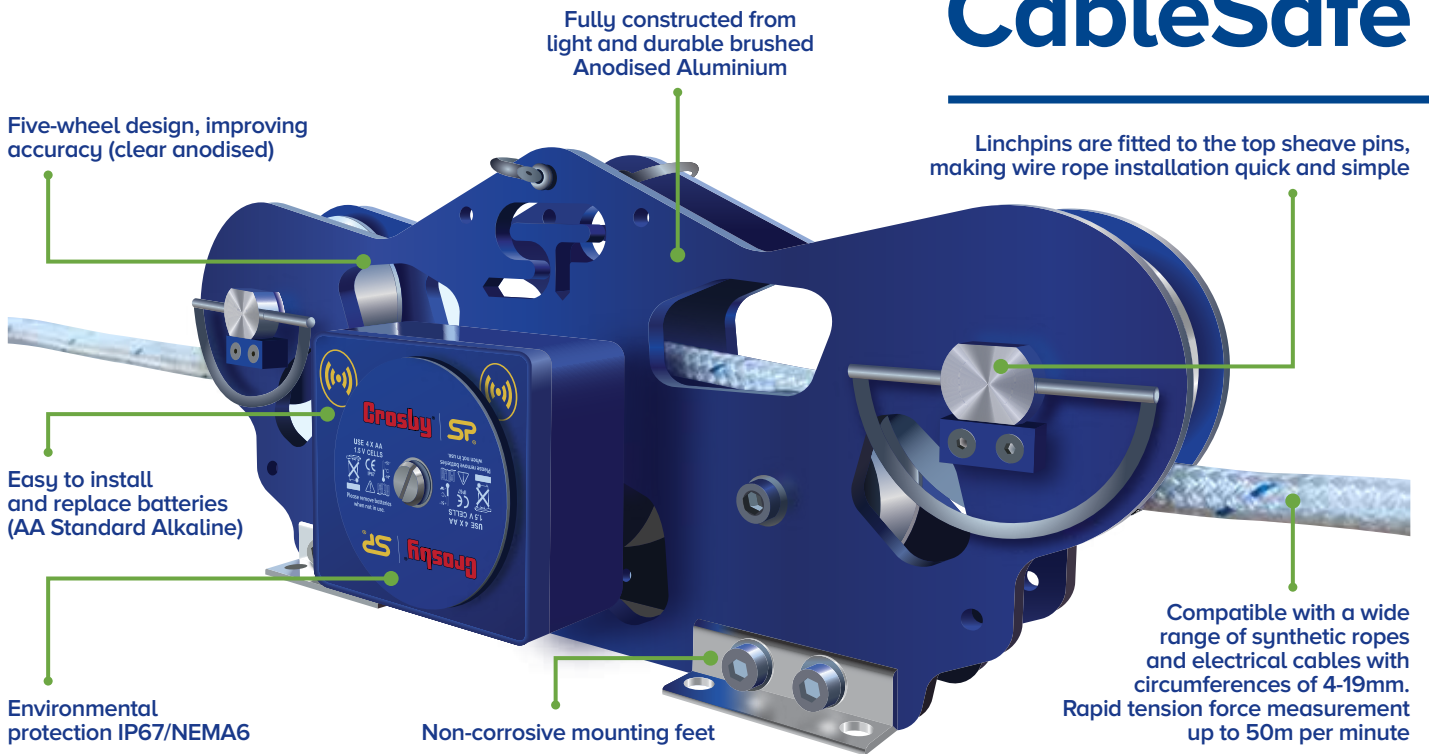

**In addition to the TIMH range, the CableSafe is the continued evolution of Straightpoint's running line tensiometers. When used in the field, it will allow the user to monitor tension with exceedingly high levels of accuracy, which ensures rope/cables do not become overstretched or break.**

When using a capstan winch to unwind electrical cable from a reel/spool, you will be able to integrate the CableSafe within this set-up to ensure that it is being pulled at a safe tension level. This helps the line maintain its transmissions capability, prevent it becoming a fire hazard risk, and it also stops the need of furthering work in order to remove and replace it. The contractor is gifted with decreased liability, dramatically increasing peace of mind. Using CableSafe on cable pulls reduces liabilities on cable installations, making it ideal for the following applications:

- Measure tension when pulling electrical cables – protect against fractures or elongation
- Measuring tension on synthetic rope when erecting delicate structures using gin poles and capstan winch

Another example of best use is during the installation of cell phone towers or similar delicate structures. The product helps ensure structure-to-ground ropes which are connected to a gin pole and pully system. Do not exceed maximum tension whilst lifting sections of the tower to the top because there can be the possibility of the rope becoming snagged, causing greater tension to be loaded upon the system. With heavy materials being lifted to great heights; this would create a major safety hazard leading to a catastrophic failure, endangering lives. Avoid the unknown through accurate monitoring, especially when risks are high.

What distinguishes it, apart from previous versions of this type, is the developed lightweight design, allowing easy transportation and usage. Providing up to 500 hours battery life, you can be assured there will not be any loss of power before your work day has ended. High level IP67/NEMA6 ingress protection allows it to be used in a variety of heavy weather conditions and dusty environments. These features, as a collective, means that it will be an invaluable and reliable tool in your work-related armoury.

The five-wheel design and gravity catches, with top sheave pins, allows for fast and simple rope attachment set-up. The accuracy is further improved over three-wheel alternatives.

When used with a cable/rope pulling device, you can remotely monitor the tension on the line using your smart handheld device via a Bluetooth connection\*. With the operator locating themselves up to 100m/328ft away from the Cable Safe, it will allow them to survey job progress at a safe distance.

*\*The 'HHP' app is available to download for free (Android/iOS) and is compatible with all SP wireless products.*

## Applications:

- Fibre-optic cable pulling using turret winches
- Water gates for dams
- Offshore rescue and retrieval
- Capstan rope/cable winding
- Broadcast and telecommunications
- Erecting towers (maintaining structural capacity)
- Service and maintenance of cell towers

## Features and benefits:

- Simple to use and set up
- Remote monitoring using smart phone via Bluetooth
- Rapid tension force measurement - Up to 50m/164ft per minute
- Able to be used in all weather and air quality conditions
- Easy to install and replace batteries (4 x AA standard Alkaline)
- Fully constructed from light and durable hard Anodised Aluminium
- Five wheel design improving accuracy (clear anodised)
- Linchpins are fitted to the top sheave pins making wire rope installation quick and simple
- Maintenance free heavy duty needle bearings
- Compatible with a wide range of rope circumferences – 4-19mm/0.16"- 0.75"
- Design validated by F.E.A.
- IP67 ingress protection / NEMA6 – heavy protection against dust and rain

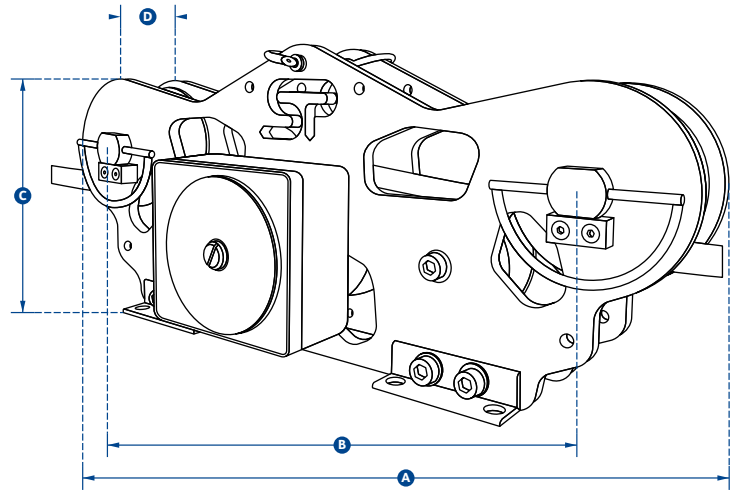

Part Number	CS10T
Capacity	10te
	22,000lb
Resolution	0.01te
	20lb
Rope Ø	4-19mm
	5/32" - 3/4"
Weight	4.5kg
	10lb
Battery Type	4 x AA Alkaline
Battery Life	500hrs
Operating Temp	-10°C to +50°C / 14°F to 122°F
Accuracy	±2% of full scale
Range	Bluetooth 100m / 328ft
Protection	IP67/NEMA6
Maximum Speed	50m per minute / 164ft per minute
Dimension A	422mm
	16.60"
Dimension B	330mm
	13"
Dimension C	152mm
	6"
Dimension D	36mm
	1.4"