

SHIMPO

TRC Series

DIGITAL TORQUE CHECKER Series

Operation Manual

Read the manual thoroughly prior to operation.

Use the instrument only after reading the complete manual.

Follow all safety precautions.



Safety Precautions

Be sure to read the entire instruction manual thoroughly before initial set-up, operation and maintenance. The instruction manual provides three grades of safety precautions: "Danger", "Warning" and "Caution". Follow these precautions.



indicates possible death, severe injury or fire



"Warning" marking indicates possibility of a serious injury if the user does not follow the instruction.



"Caution" marking indicates possibility of severe bodily or object damage if operated improperly.

The following marks indicate the sort of contents which are completed with.

This mark indicates a warning.

This mark indicates a prohibited operation.



















This mark indicates a note for this warning.

Warning



Heavy! Pay close attention to location and conditions around TRC. Dropping the TRC may cause damage or serious injury.

 **Caution**

 <p>Never exceed torque ratings. May damage sensor and other parts. May cause damage or injury.</p>	 <p>Place TRC in a location maintenance and check are easy.</p>
 <p>Do not carry TRC by AC power cable. May cause electric shock, fire and/or injury.</p>	 <p>Fix object securely. May cause damage or injury.</p>
 <p>Confirm the specified AC voltage. Other than specified voltage may cause damage, electric shock, fire and/or injury</p>	 <p>Do not damage AC cable. May cause electric shock, fire and/or injury.</p>
 <p>Do not substitute AC adapter. Use only the adapter supplied with the unit. Use of other than specified ac adapter may cause damage, electric shock, fire and/or injury.</p>	 <p>Do not use except with 115VAC. May cause electric shock, fire and/or injury.</p>
 <p>Insert AC connector into outlet securely. May cause electric shock, fire and/or injury</p>	 <p>Do not insert plug into AC outlet if hands are wet or moisture present. May cause electric shock, fire and/or injury.</p>
 <p>Do not alter, repair or dispose of TRC or batteries improperly. May cause damage, accidents and void warranty.</p>	 <p>Do not pull out the AC plug by the only. Carefully pull on plug cable. Pulling on cable may cause electric shock.</p>
 <p>Do not use with AC power in an area where there is dust. An electrical spark may cause fire.</p>	 <p>Do not use in the following: Direct sunshine, condensation, dust or caustic chemicals, combustible gases, oils, water, salts.</p>
 <p>To clean, gently wipe with a soft cloth. No volatile chemicals such as usage of Benzene, Thinner, or Alcohol are to be used to clean TRC</p>	 <p>Operate within 32-104° F (0-40° C) Outside specified temperature range may alter operation of TRC.</p>
 <p>Check operation of TRC and calibrate periodically.</p>	 <p>Humidity range 35 - 85%RH (Not condensation) Operation outside humidity range may alter operation of TRC.</p>

Contents

1	Feature	1
2	Confirmation of Product Packing	1
3	Names and Functions of Components	2
3.1	Mainframe	2
3.2	Operation Panel	3
3.3	Main Display	4
3.3.1	Main Display/Setup Values	4
3.3.2	Unit/Status Indicators	4
3.3.3	Battery Indicator	5
4	Parameters	5
4.1	Function Setting	5
4.1.1	Function Mode	5
4.1.2	Operation	5
4.2	High/Low Limit Setting for Comparator	8
4.2.1	Pattern No. Setting	8
4.2.2	Operation	9
5	Measurement Mode	10
5.1	Peak Mode	10
5.2	Mean Mode	10
6	Comparator Function	11
7	Measuring	12
7.1	Measurement of Torque Wrenches	12
7.2	Measurement of Electric Screwdrivers/Torque Drivers	12
7.3	Zero Adjustment	13
7.4	Measuring	13
7.5	Mounting Bracket	14
8	Memory Function	14
8.1	Saving Data in Memory	14
8.2	Display Memory Data	15
8.3	Clearing Stored Data (Latest Memory Data)	16
8.4	Clearing Stored Data (Each Pattern No.)	16
8.5	Clearing Stored Data (All Memory Data)	16
9	DigiTorq_TRC	17
9.1	Feature of DigiTorq_TRC	17
9.2	Download DigiTorq_TRC	17
9.3	Battery Life and USB	17
10	Support	17
10.1	Repair and Calibration	17
10.2	Warranty	17
11	Specifications and Dimensions	18
11.1	Specification	18
11.2	Dimensions	19

1 Feature

- Two measurement modes: Mean, Peak
- Peak hold & Auto reset of peak display
- Go/No Go judgment by comparator functions (LED indicator and Buzzer)
- Available 10 patterns of High/Low torque limits for judgment
- 300 data memories for each pattern (Total: 3,000 data)
- USB communication to PC (with “DigiTorq_TRC” operation software:)
- Selectable units: lb-in, N-m, N-cm, kg-cm
- Selectable Measurement periods: 1, 2, 4, or 8 times/sec

2 Confirmation of Product Packing

1. Mainframe (1)



2. Adapter for torque driver (1)



3. AC adapter/charger (1)



4. USB cable (1)



5. Mounting Bracket (1)



6. Bolt M6x15 for mounting bracket (2)



7. Operation manual

8. Warranty card (1)

3 Names and Functions of Components

3.1 Mainframe

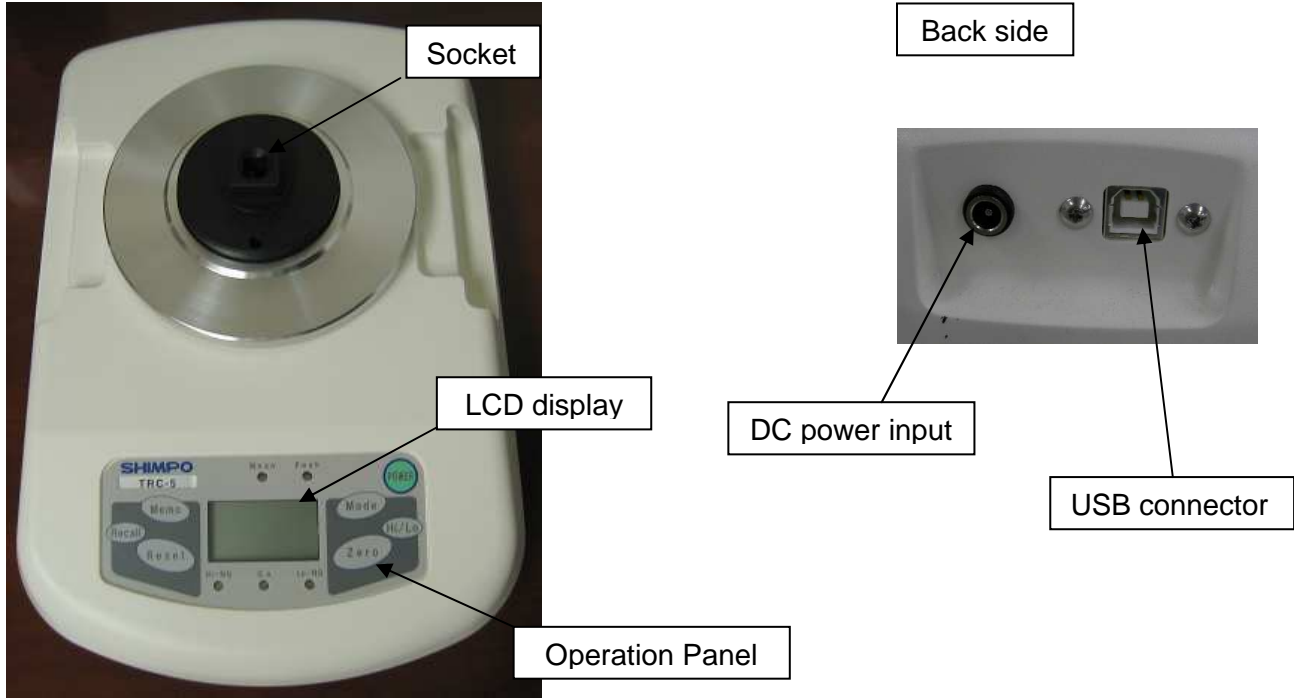

Socket	Insert torque wrench or torque driver adapter
Operation Panel	LCD display, Keys, LED indicators
USB Connector	USB communication (B type)
DC Power Input	Insert AC adapter/charger when AC power supply is used or battery is being charged.

3.2 Operation Panel

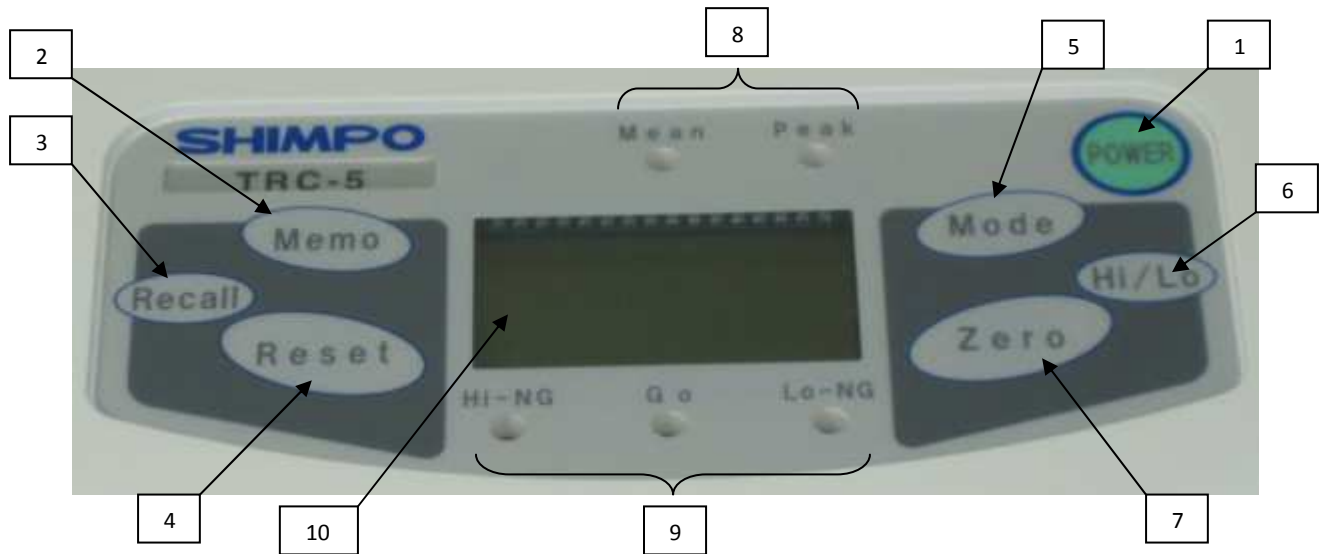

1	POWER key	Power the unit on or off.
2	Memo key	When in Peak mode, data is stored. Note: In "Mean" mode, Memo key has no function.
3	Recall key	Recall the peak data stored in "Peak" mode. Note: In "Mean" mode, Recall key has no function.
4	Reset key	Peak reset function in "Peak" mode.
5	Mode key	Select "Mean" or "Peak" mode of operation
6	Hi/Lo key	Sets the high/low limit values.
7	Zero key	Sets Zero in "Mean" and "Peak" mode.
8	Mode LED's	Indicates which mode is selected: "Mean" or "Peak".
9	Comparator LED's	When the high/low limit values are enabled, the LED indicates: Hi-NG or Go or Lo-NG is ON. When the high/low limit values are disabled, all LED's are off.
10	Main display	Displays measured values and status indicators. Includes units of measure, battery status and function status.

3.3 Main Display

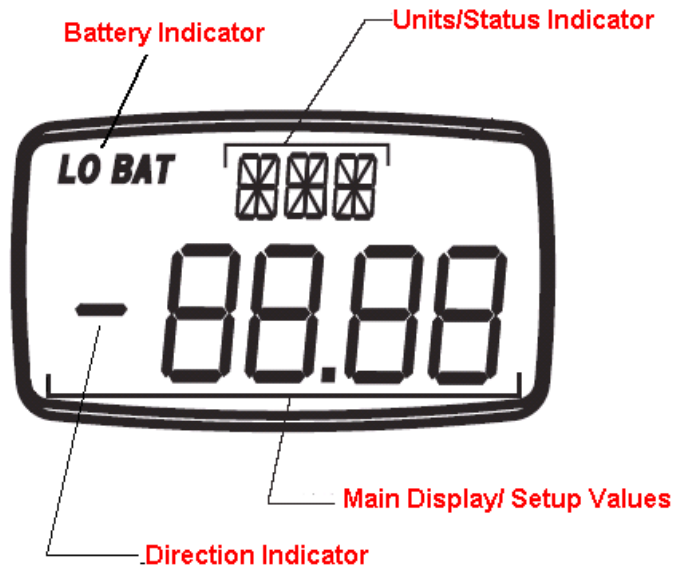

3.3.1 Main Display/Setup Values

Main display shows four digits including decimal point.

The + sign means CW direction torque, the – sign means CCW direction torque in Mean mode.

IMPORTANT NOTE: In the case of Peak mode selection, the sign is always +.

3.3.2 Unit/Status Indicators

Located on the upper part of display, this shows the unit of measure selected.

It also serves as a sub display under function mode or status. The example display is shown in below.

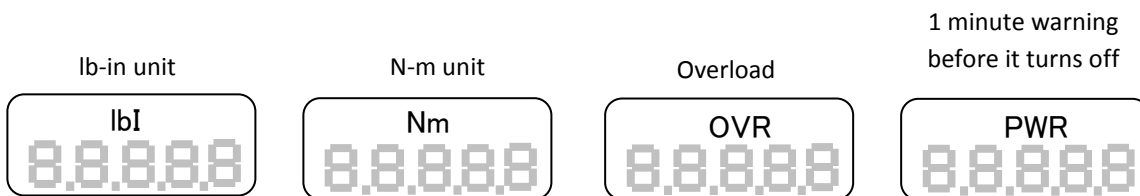

3.3.3 Battery Indicator

Displayed according to battery status.



“LO BAT” blinking:
Battery diminished.
Connect AC adapter/charger for charge.



“BAT”:
Charging by AC adapter/charger.

4 Parameters

4.1 Function Setting

4.1.1 Function Modes

Function modes are as follows.

Item	Sub Display	Setting Contents	Initial setting
Auto reset	F01	OFF/1/2/5 sec	OFF
Unit of torque	F02	lb-in/N-m/N-cm/kg-cm	lb-in
Display update time	F03	1/2/4/8 [times/sec]	4
Auto power off	F04	OFF/10 [minutes]	10
Unit No.	F05	0-99	0

4.1.2 Operation

With power off, press and hold Zero key then press POWER key.

Hold Zero key until the display shows “F01”.



Next page

4.1.3 <Auto Reset Selection>

The Auto Reset function automatically resets Peak after each setting period.

The Peak Reset function operates the same as pressing Reset key.

(Current setting is displayed first.)

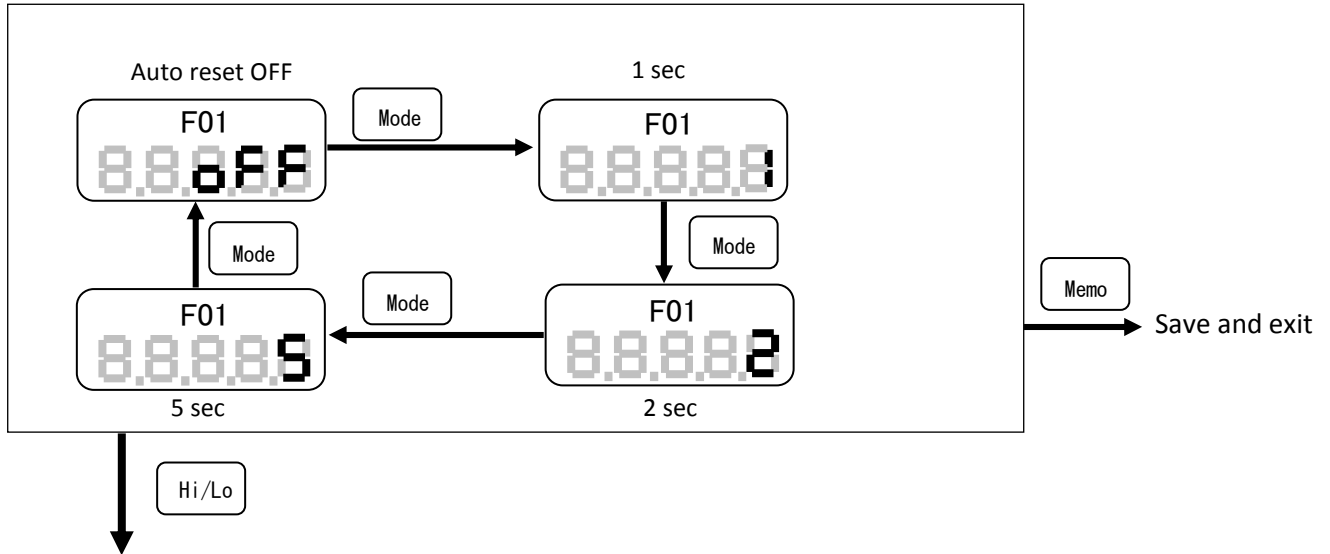

4.1.4 <Units of measure selection>

The torque units are selectable: lb-in, N-m, N-cm and kg-cm.

(Current setting is displayed first.)

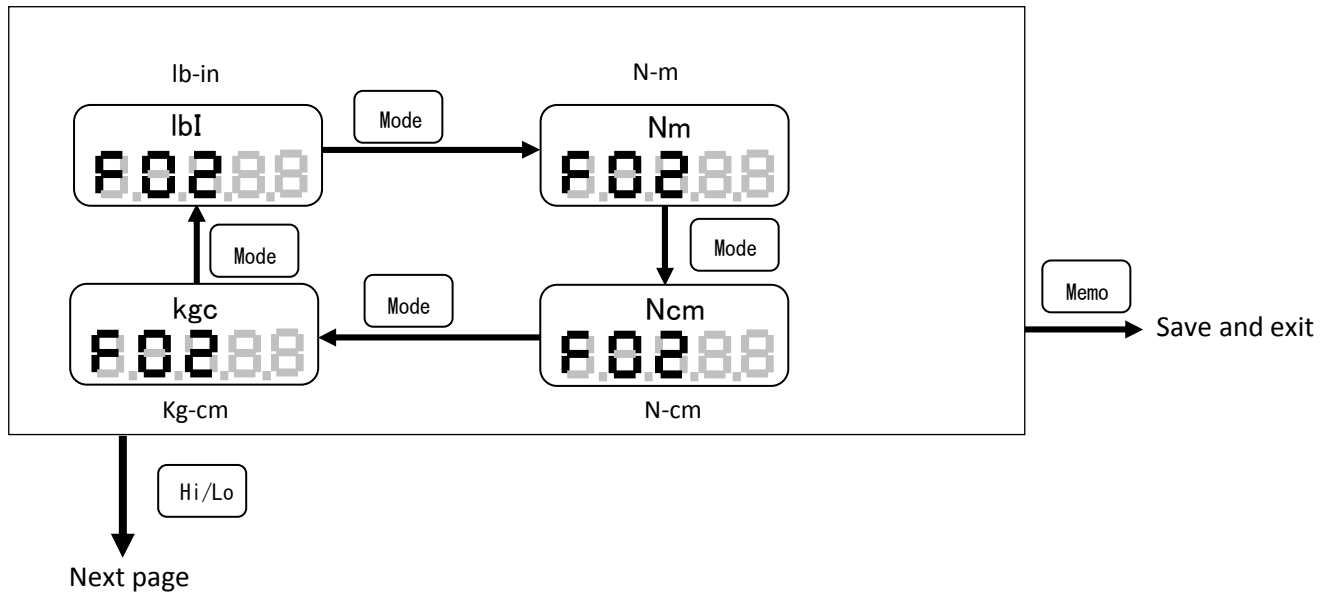

4.1.5 <Display Update Time Setting>

Display update time is selectable from 1/2/4 or 8 times/sec.

(Current setting is displayed first.)

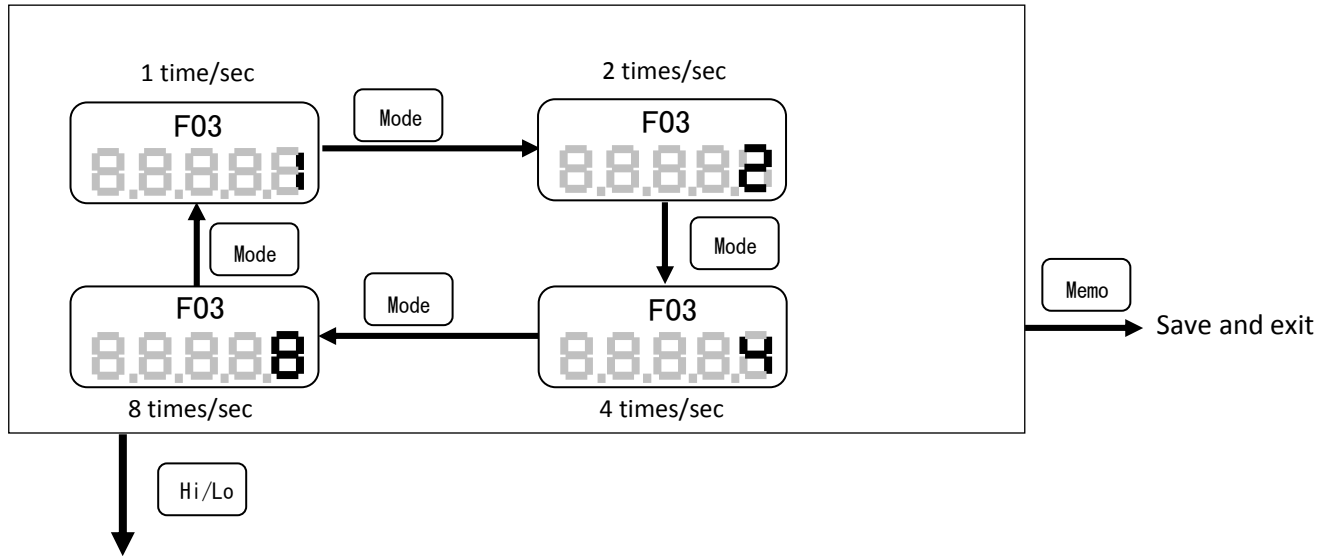

4.1.6 <Auto Power Off Setting>

If the TRC is on battery power and there is no activity for 10 minutes, the TRC automatically powers off to conserve battery power. This option may be disabled. Auto Off is disabled when connected to AC adapter/charger.

Auto Off time defaults to 10 minutes. No other time is available.

(Current setting is displayed first.)

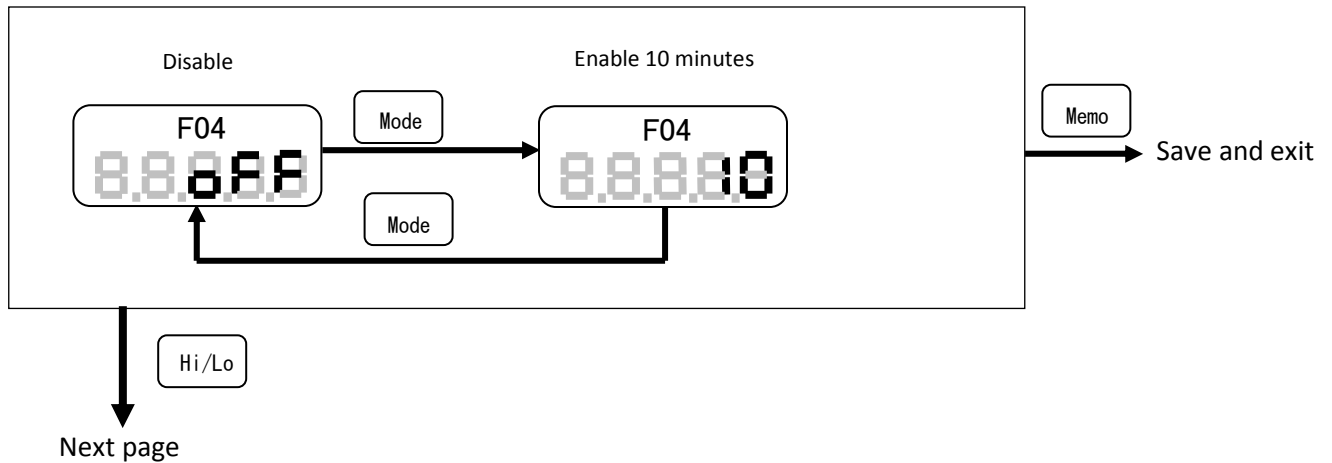

4.1.7 <Unit No. Setting>

The ID No. can be individually applied.

(Current setting is displayed first.)

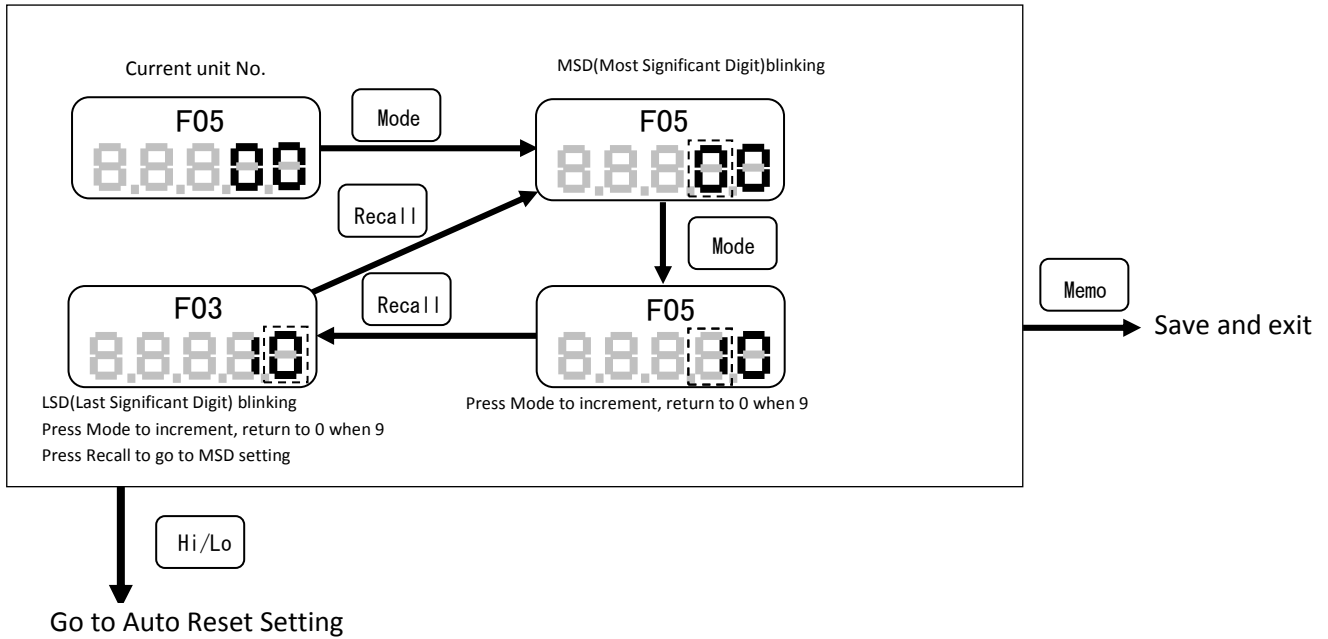

4.2 Comparator settings for High/Low Limits

4.2.1 Pattern No. Setting

The TRC can store up to 10 patterns of High/Low torque limits.

This section describes how to set the pattern No.

The pattern No. is from 0 to 9.

When a torque unit of measure is displayed, the Comparator function may be disabled.

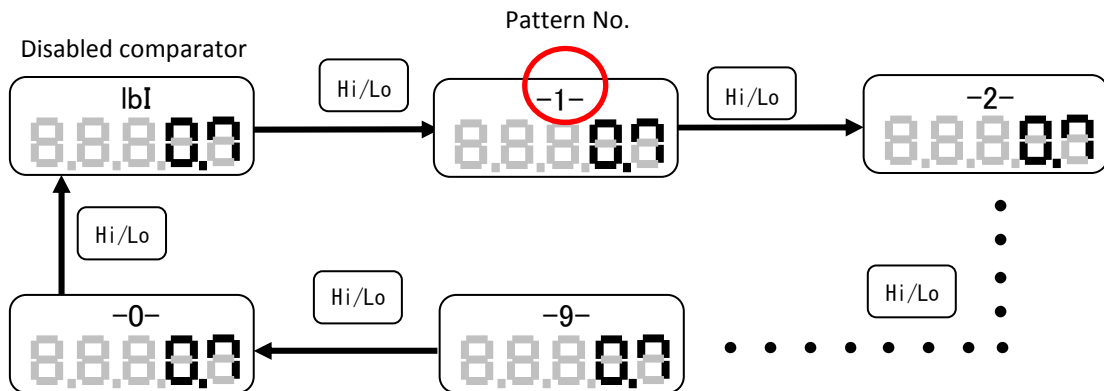

4.2.2 Operation

Select the pattern number according to above Section 4.2.1. Pattern No. Setting.

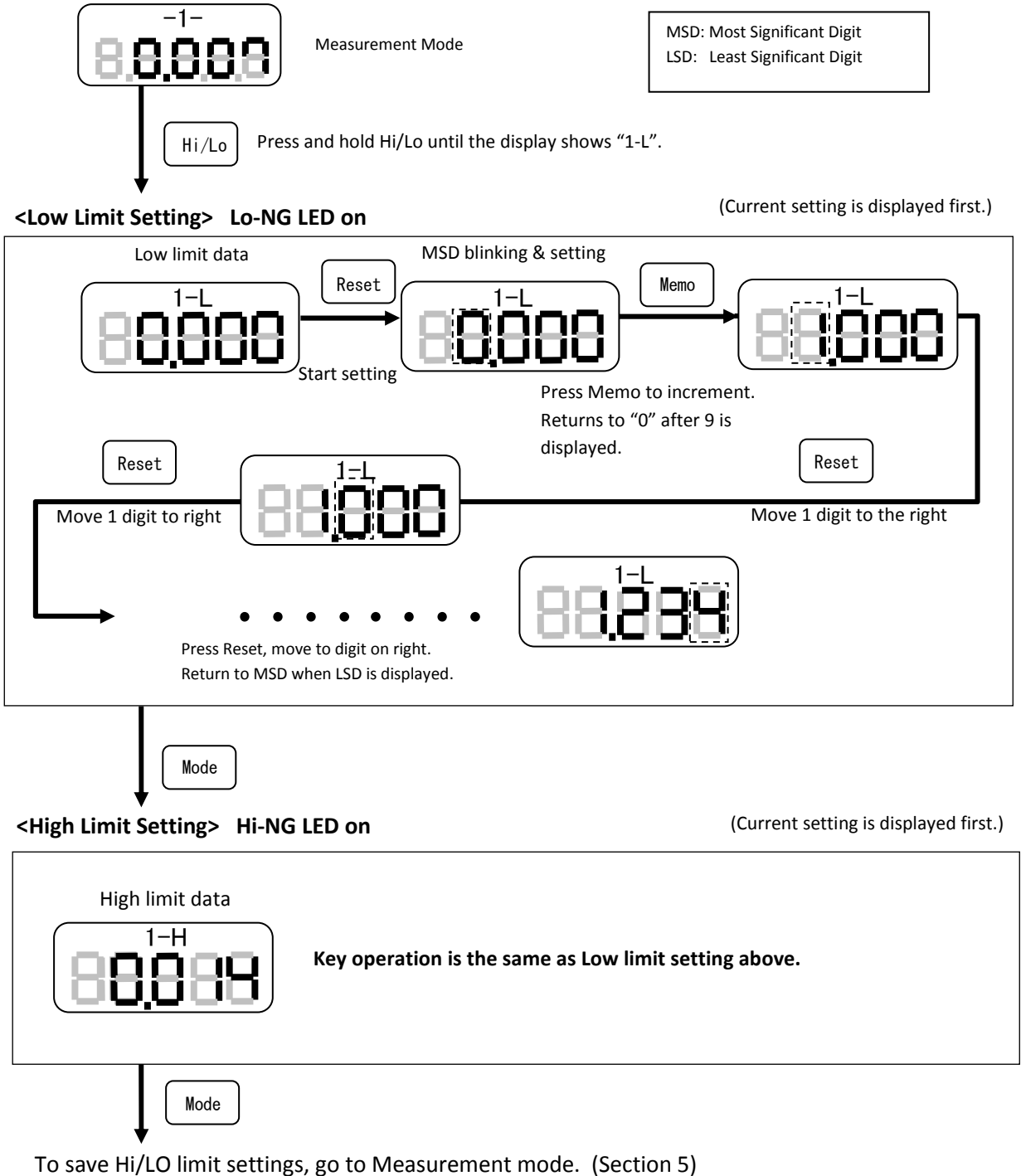

Note: Low limit value must be smaller than High limit value. If the setting data is incorrect, all digits will be blinking. Turn TRC off and reset limits.

5 Measurement Modes

Peak, Mean Measurement modes are available on the TRC:

To select the measuring mode required for testing, follow the settings below.

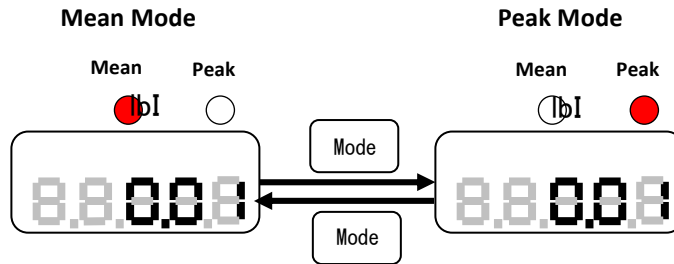

5.1 Peak Mode

The Peak value displayed on the TRC is measured at 1,000 times per second. (1000Hz)

The Peak value is reset by pressing the Reset key or activating the Auto reset function (refer to 4.1.3 Auto Reset Setting).

Set zero by pressing Zero key.

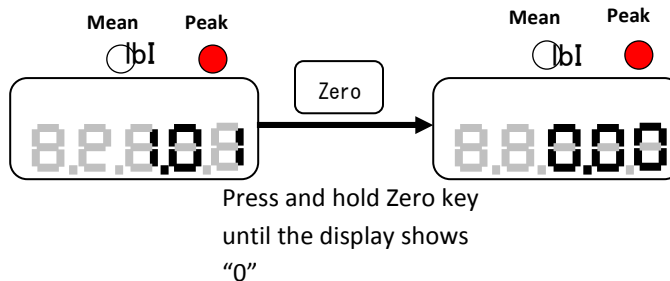

5.2 Mean Mode

The mean mode is the real time value based on the average data captured in 1,000 samples per second. (1000Hz)

F03	Display Update time	Average
1	1 time/sec	Displays the average of 1,000 measuring data by 1msec sampling
2	2 times/sec	Displays the average of 500 measuring data by 1msec sampling
4	4 times/sec	Displays the average of 250 measuring data by 1msec sampling
8	8 times/sec	Displays the average of 125 measuring data by 1msec sampling

6 Comparator Function

- This function compares the High/Low limits and measured data (Mean Mode) or peak data (Peak Mode) or memory data. The result is displayed by Comparator LED indicators.
 - If both High and Low limits are set to 0, the Comparator function is deactivated. Refer to 4.2.2 Operation.
 - The buzzer sounds and the “Go” LED illuminates when the displayed data is between the High and Low limits.
 - In Peak mode, the buzzer sounds when the peak value is fixed.
 - In Mean mode, the buzzer sounds every 1 sec.
- Note: When the displayed value is less than 1% of the torque rating, the buzzer does not activate.
- Comparison is used with all completed data.

<Example of comparator function>

High limit = 100, Low limit = 50

Measurement of CW direction

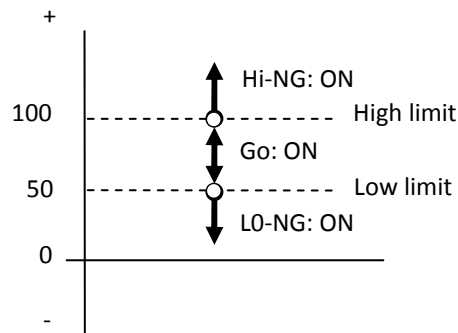

Measurement of CCW direction

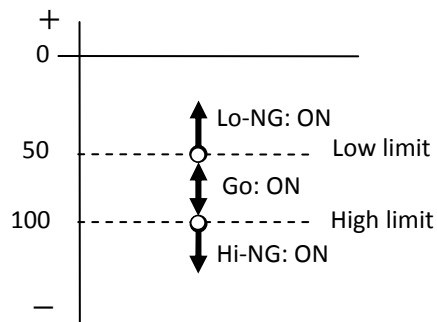

7 Measuring

7.1 Torque Wrench - torque measurement

To measure torque, insert the torque wrench square drive into the TRC socket attachment.

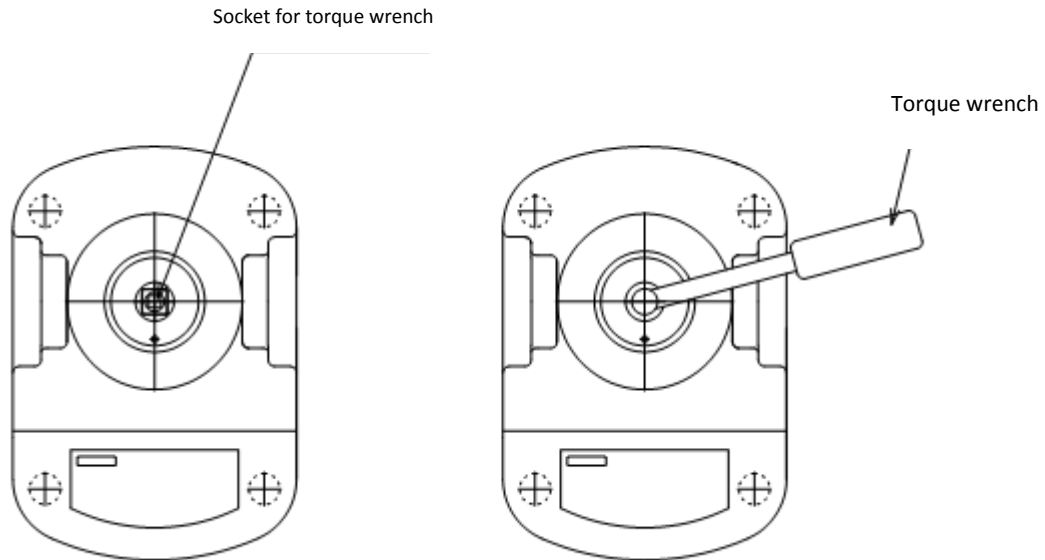

7.2 Electric Screwdrivers/Torque Driver - torque measurement

To measure torque, insert the adapter into the attachment of the TRC as shown below.

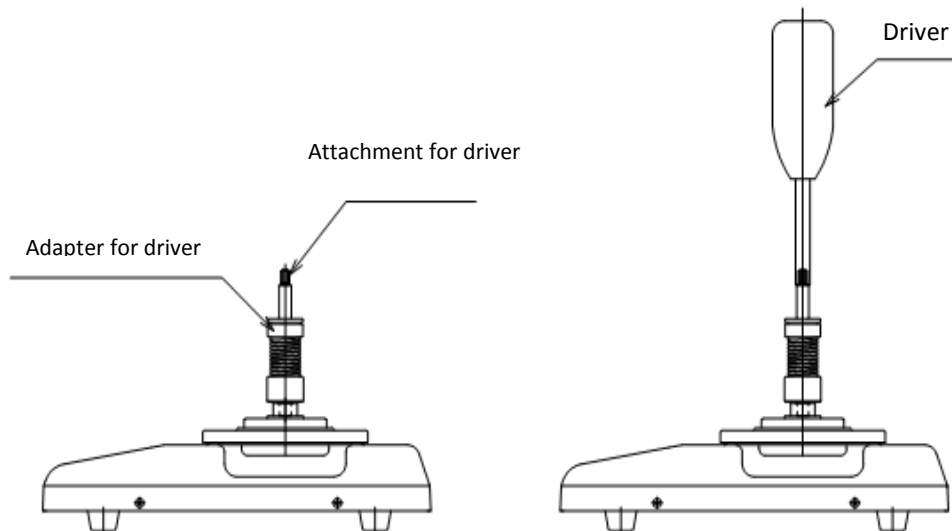

The torque driver adapter is designed to measure in only the CW (tightening) direction.

Note:

The adapter is a consumable product.

Replace the adapter when it is impossible to perform a repeatable measurement.

Tighten (CW direction)

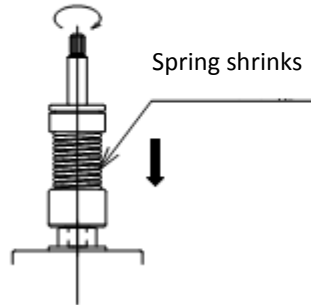

Loosen (CCW direction)

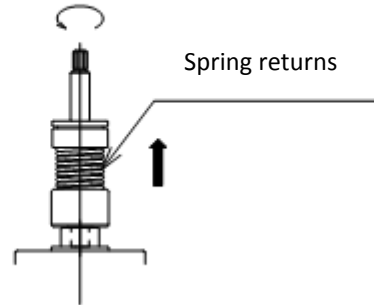

7.3 ***Zero Adjustment***

In "Mean" mode, press the Zero key when the display does not display "0" and no torque is applied.

In "Peak" mode, press the Zero key when the display does not display "0" if the automatic peak reset function is not activated.

7.4 ***Measuring***

The measured torque data is displayed with a given torque test.

When the TRC is in "Peak" mode, press Reset key to reset the Peak function before the next torque test.

NOTE: Peak reset cannot operate while torque is applied.

7.5 Set Mounting Bracket

Secure the TRC to a work bench or other suitable surface by using the mounting bracket accessory if the TRC moves during measurements.

Procedure to mount the mounting bracket:

1. Prepare the mounting bracket (1) and bolts M6x15 (2) of accessories.
2. Set the mounting bracket to the bottom of the unit by the bolts as shown below.
3. Set the unit to worktable using two holes (diameter 7mm).

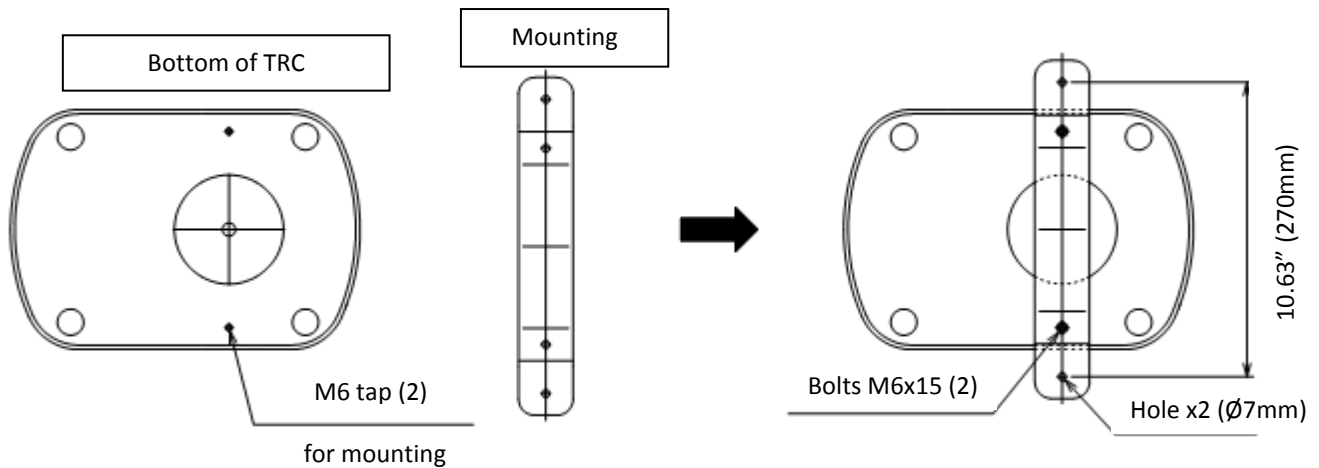

8 Memory Function

8.1 Saving Data in Memory

Measuring torque data can be stored in the unit by pressing Memo key.

The feature is only available in Peak mode.

The unit is able to store 300 data for each pattern of High/Low limits.

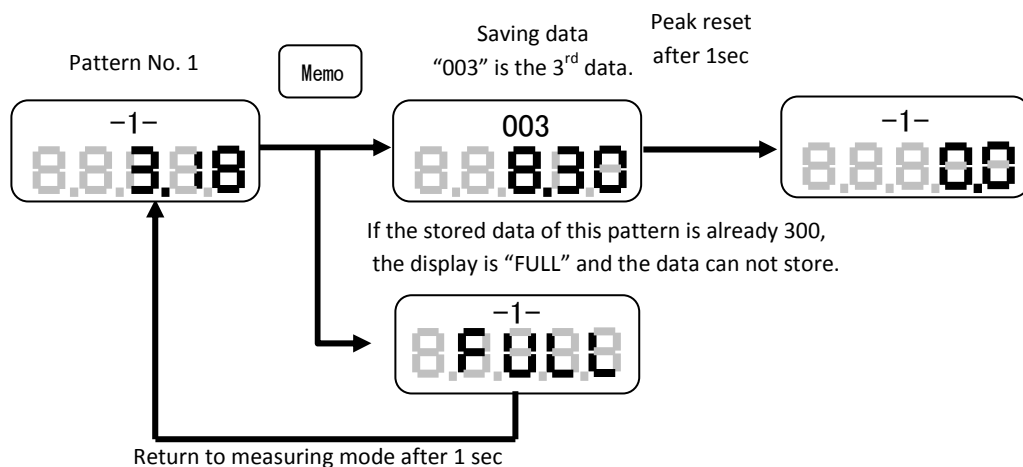

8.2 Display Memory Data

Select Peak mode, press the Recall key and the TRC display will indicate the number of data stored in the memory.

The Memory data is displayed from the last number stored.

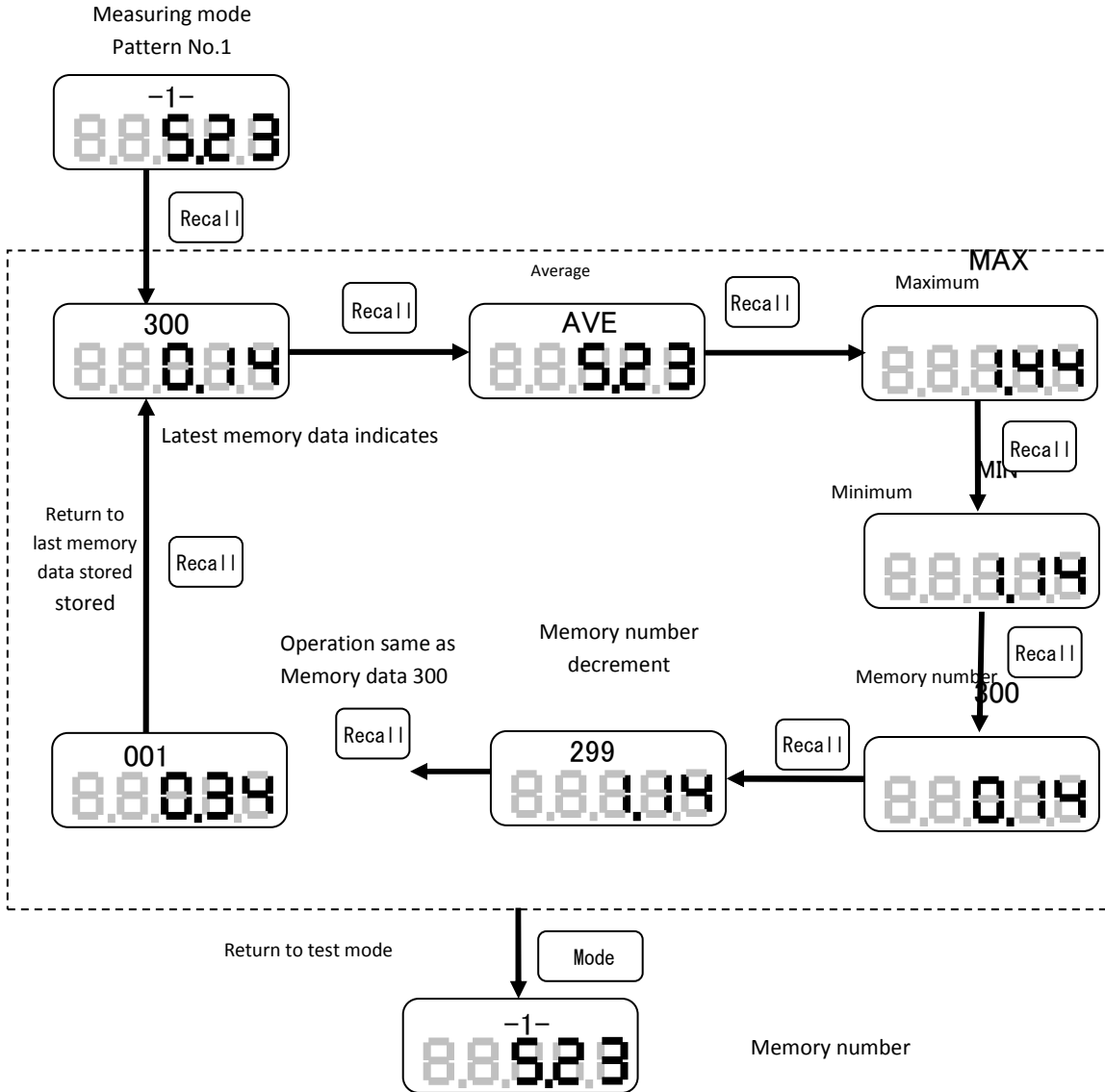

8.3 Clearing Stored Data (Latest Memory Data)

When the latest memory data is displayed, press and hold the Zero key until “Clr” is shown in the display.

Press and hold until clear display

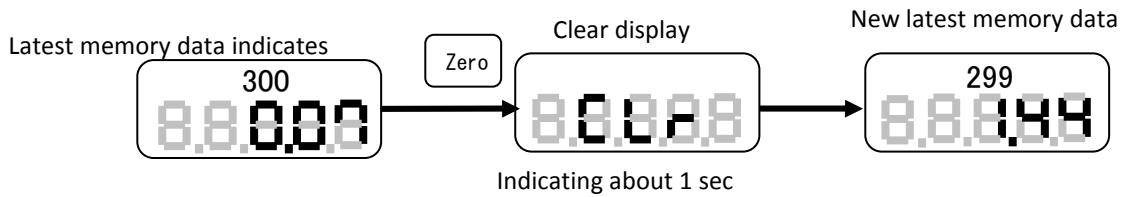

In case of latest memory number = 001:

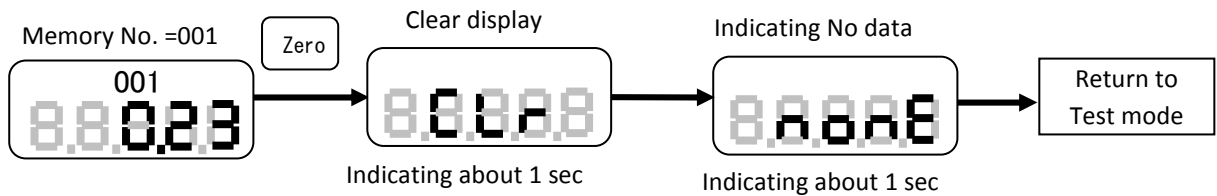

8.4 Clearing Stored Data (Each Pattern No.)

When the pattern No. is displayed, press and hold the Memo key and the Zero key until “Clr” is shown in display.

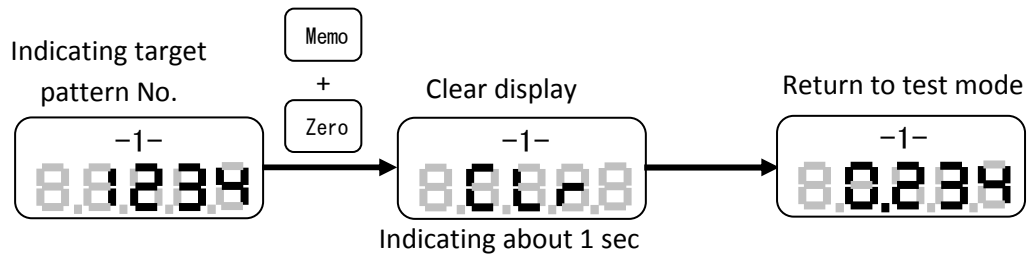

8.5 Clearing Stored Data (All Memory Data)

Power off. Press and hold the Memo key and power on. Continue to hold the Memo key until “All Clr” is shown in the display.

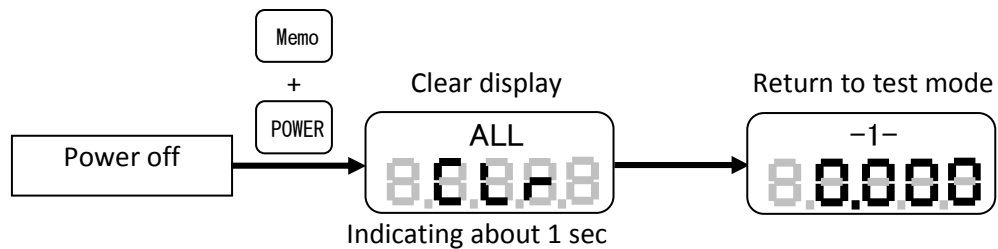

9 DigiTorq_TRC

When you connect the TRC to a PC with the USB cable, your PC is able to obtain test data from the TRC. Installation of the DigiTorq_TRC application software is required.

9.1 Feature of DigiTorq_TRC

DigiTorq_TRC is an add-in software for MS Excel^{®*}

The measurement data and the memory data of the unit can be directly sent to an Excel spreadsheet where graphing and data analysis is easy.

*Excel is a registered trademark of Microsoft Corp.

9.2 Download DigiTorq_TRC

The DigiTorq_TRC is available for free at the following web address:

<http://www.shimpoinst.com/software.php>

The manual is included with the software download, and is available separately.

9.3 Battery Life and USB

Leaving the USB cable connected to the TRC will drain battery power at a faster rate. Only connect the TRC USB cable when communicating or use the AC adapter/charger.

10 Support

10.1 Repair and Calibration

Please contact your Shimpo dealer for information regarding the repair and calibration of your TRC.

10.2 Warranty

Nidec-Shimpo Corp. warrants, to the original purchaser of new products only, that this product shall be free from defects on workmanship and materials under normal use and proper maintenance for one year from the date of original purchase. See warranty card.

11 Specifications and Dimensions

11.1 Specification

TRC Series Digital Torque Checker				
TRC Models		TRC-2	TRC-5	TRC-10
Measuring Units		N-m, N-cm, lb-in, kg-cm		
Measuring Range		0.020-2.000 N-m	0.050-5.000 N-m	0.10-10.00 N-m
		2.0-200.0 N-cm	5.0-500.0 N-cm	10-1000 N-cm
		0.18-17.7 lb-in	0.45-44.25 lb-in	0.89-88.50 lb-in
		0.21-20.39 kg-cm	0.51- 50.99 kg-cm	0.1-102.0 kg-cm
Display	Main Display	4-digit LCD display, Character height 12mm		
	Sub Display	3-digit LCD display, Character height 7mm		
	Mode Display	Mean, Peak (red LED indicators)		
	Comparator Display	Hi-NG, Go, Lo-NG (green and red indicator)		
Buzzer		Available (Result of comparator, completing to measure, etc.)		
Accuracy		+/- 0.5% Full Scale		
Measuring	Mean Mode	Measuring real time torque		
	Peak Mode	Measuring peak torque		
Display Update Time		Select from 0.125sec (8 times/sec), 0.25sec (4 times/sec), 0.5sec (2 times/sec), 1 sec (1 time/sec).		
Sampling Rate		100 times/sec (10msec)		
Memory	Memory data number	Total 3,000 data (300 data/ each pattern [Total 10 patterns])		
	Statistical Process	Average value, Maximum value, Minimum value		
Data Output		USB1.1		
PC Software		DigiTorq_TRC(free download from web site: www.shimpoinst.com)		
Standard Accessories		Torque adapter for driver, AC adapter/charger, USB cable, Mounting bracket, bolts for mounting bracket (2 pcs)		
Power	Battery	Built in nickel metal hydride battery (NiMHd)		
	AC adapter/charger	100-240VAC input/ 9VDC 300mA		
Dimensions DxHxW inch(mm)		12.60"x3.82"x8.66" (320x97x220mm)		
Shipping Weight		18lb (8kg)		
Operation Environment		32-104° F (0 – 40° C)/ 35-85% RH (non condensation)		
Battery Type/ Battery Life		Ni-MH / 8 hours after full charge		
Battery Recharger Time		Maximum 16 hours		

11.2 Dimensions

