

Model SC-PM4

Operating Instructions

Valid as of: 01.10.2016 • Please keep the manual for future reference!

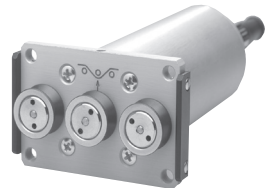

Contents

1	Warranty and Liability	3
1.1	Notices within the Operating Instructions	3
1.2	Responsibilities of the Operating Company	3
1.3	Responsibilities of the Personnel	3
1.4	Informal Safety Measures	4
1.5	Training of the Personnel	4
1.6	Intended Use	4
1.7	Dangers in Handling the Device	4
1.8	Copyright	4
1.9	Declaration of Conformity, RoHs II and WEEE Registration	4
2	General Information	5
2.1	Specifications	5
2.2	Pin Assignments of connectors and cable	6
2.3	Connecting the SC-PM4	7
2.3.1	Connecting by the USB interface	7
2.3.2	Connecting by the RS 422 interface	8
2.4	Delivery Includes	9
2.5	Optional Accessories	9
2.6	Unpacking	9
3	Operation	10
3.1	Operating Elements	10
3.1.1	Switch-On	10
3.1.2	Switch-Off	10
3.2	Operating Procedure	11
3.3	Settings	11
3.3.1	Calculation of the damping factor	12
3.3.2	Sub menu calibration	13
3.4	Sensor Calibration	13
3.4.1	ZERO and GAIN Adjustment	14
4	ANALOG Interfaces	16
5	Online Sensor Specifications	17
5.1	TS, FS and MZ Series	17
5.2	SF Series	17
6	Service and Maintenance	18
7	Cleaning	18
8	Correspondence	18
9	Repairs	18

1 Warranty and Liability

In principle, the supply of the device is subject to our “General Conditions of Sale and Delivery.” These have been provided to the operating company on conclusion of the contract, at the latest.

Warranty:

- SCHMIDT display units are warranted for 12 months.

Parts subject to wear, electronic components and measuring springs are not covered by the warranty. No warranty or liability will be accepted for bodily injury or property damage resulting from one or several of the following causes:

- Misuse or abuse of the device.
- Improper mounting, commissioning, operation and maintenance of the device (e.g. verification interval).
- Operation of the device if any safeguards are defective or if any safety and protection precautions are not properly installed or not operative.
- Failure to comply with the notices in the Operating Instructions regarding transport, storage, mounting, commissioning, operation, maintenance and setup of the device.
- Any unauthorized structural alteration of the device.
- Insufficient inspection of device components that are subject to wear.
- Opening the device or improper repair work.
- Disasters caused by the effects of foreign objects or by force majeure.

1.1 Notices within the Operating Instructions

The fundamental prerequisite for the safe handling of this device and its troublefree operation is the knowledge of the basic safety notices and safety instructions.

These Operating Instructions contain the most important notices for the safe operation of the device.

These Operating Instructions, in particular the safety notices, must be observed by any person who works with the device. In addition, the local valid rules and regulations for the prevention of accidents must be complied with.

The representations within the Operating Instructions are not true to scale.

The dimensions given are not binding.

General indications of direction, such as FRONT, REAR, RIGHT, LEFT apply when viewing the front of the device.

1.2 Responsibilities of the Operating Company

In compliance with the EC Directive 89/655/EEC, the operating company agrees to only permit persons to work with the device who:

- are familiar with the basic regulations on industrial safety and accident prevention and who have been trained in handling the device.
- have read and understood the chapter on safety and the warning notices in these Operating Instructions and have confirmed this with their signatures.
- are examined regularly on their safe and conscientious working method.

1.3 Responsibilities of the Personnel

All persons who work with the device agree to perform the following duties before starting work:

- to observe the basic regulations on industrial safety and accident prevention.
- to read the chapter on safety and the warning notices in these Operating Instructions and to confirm with their signatures that they have understood them.

1.4 Informal Safety Measures

The Operating Instructions must always be kept on hand where the device is operated. Apart from the Operating Instructions, the general and local valid regulations on accident prevention and environmental protection must be provided and complied with.

1.5 Training of the Personnel

Only trained and instructed personnel is permitted to work with the device. The responsibilities of the personnel must be clearly defined for mounting, commissioning, operation, setup, maintenance, and repair. Trainees may only work with the device under the supervision of experienced personnel.

1.6 Intended Use

The device is intended exclusively for displaying tension values measured by the online sensors from HANS SCHMIDT & CO GMBH. Any use with sensors from other manufacturers or any use exceeding this intention will be regarded as misuse. Under no circumstances shall HANS SCHMIDT & Co GmbH be held liable for damage resulting from misuse.

The intended use also includes:

- Complying with all notices included in the Operating Instructions and observing all inspection and maintenance works.

1.7 Dangers in Handling the Device

The device was designed according to the state of the art and the approved safety standards. Nevertheless, its use may cause serious or fatal injury to the user or third persons, and/or an impairment of the device or of other material assets.

The device may only be applied:

- For its intended use in a faultless condition with regard to the safety requirements.
- Malfunctions that could impair safety must be remedied immediately.
- Personal protective equipment must be used according to the EC Directive 89/686/EEC.



The device must not be operated in potential explosive areas and must not come into contact with aggressive substances.

1.8 Copyright

The copyright on these Operating Instructions remains with the company HANS SCHMIDT & Co GmbH.

These Operating Instructions are intended for the operating company and its personnel only. They contain instructions and notices that may only be reproduced on the prior written permission of HANS SCHMIDT & Co GmbH and under indication of the complete reference data. Violations will be prosecuted.

1.9 Declaration of Conformity, RoHs II and WEEE Registration

In compliance with the EU Directives 2014/30/EU and 2011/65/EU



HANS SCHMIDT & CO GmbH is registered in compliance with the German Electrical and Electronic Equipment Act (ElektroG) under WEEE Reg. No. DE 48092317.

2 General Information

2.1 Specifications

Digital Display:	LCD with backlight
Units of Measure:	cN, daN, g, kg, lb or oz (selectable)
Damping (f_g):	9-step adjustable
Output Signal:	Analog signal: 0 - 10 V DC ($R_{Load} \geq 5K \text{ Ohm}$)
Alarm Limits:	High / Low (selectable), with output signal open collector max. 30 V DC, 10 mA
Digital Output Signal (optional):	USB, RS 422 (19200, 8, N, 1)
Calibration	4 characteristic curves can be saved
Voltage Output for Sensor:	Yes
Power Supply:	15 - 24 V DC
Current Consumption:	0.300 A
Temperature Range:	10 - 45° C
Air Humidity:	85% RH, max.
Housing:	Plastic
Dimensions:	110 x 90 x 90 mm
Required Cutout:	91.5 x 91.5 mm
Weight, net (gross):	Approx. 300 g (approx. 1000 g)

2.2 Pin Assignments of connectors and cable

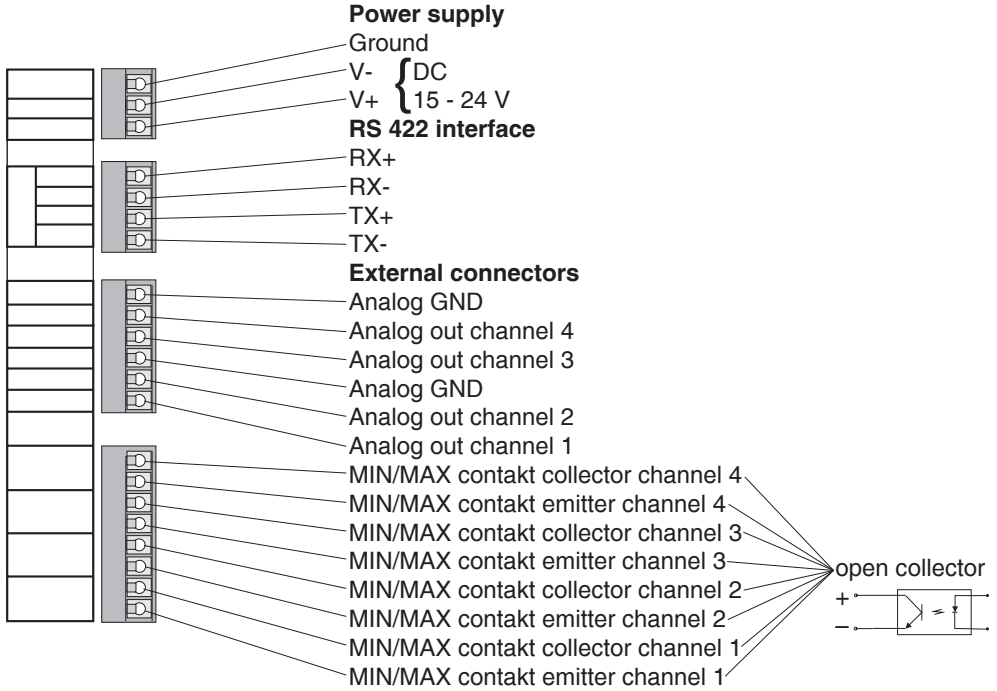

Connecting the sensors

channel 4

- 1 = Signal - In / - Signal from sensor
- 2 = Signal + In / + Signal from sensor
- 3 = Excitation - / - Sensor power supply
- 4 = Excitation + / + Sensor power supply

channel 3

- 1 = Signal - In / - Signal from sensor
- 2 = Signal + In / + Signal from sensor
- 3 = Excitation - / - Sensor power supply
- 4 = Excitation + / + Sensor power supply

channel 2

- 1 = Signal - In / - Signal from sensor
- 2 = Signal + In / + Signal from sensor
- 3 = Excitation - / - Sensor power supply
- 4 = Excitation + / + Sensor power supply

channel 1

- 1 = Signal - In / - Signal from sensor
- 2 = Signal + In / + Signal from sensor
- 3 = Excitation - / - Sensor power supply
- 4 = Excitation + / + Sensor power supply

2.2 Pin Assignments of connectors and cable

	TS Series	FS Series	MZ Series	SF Series
Signal - in [1]	white	blue	grey	white
Signal + in [2]	grey	grey	yellow	green
Excitation - [3]	rose	brown/black	brown	brown
Excitation + [4]	yellow	white	white	yellow



The cable connecting the sensor with the display unit must be shielded. The shield of the connecting cable must be connected to the metal housing of the connecting plug.

Connect only sensors which comply with the specifications given in Chapter 5.

To avoid random noise and malfunctions, make sure the cable connecting the SC-PM4 with the sensor does not run parallel to power lines or highly loaded signal lines, regardless of the type of voltage.



The requirements of the CE specification are only complied with if the SC-PM4 is equipped and operated with sensors and connecting cables supplied by HANS SCHMIDT & Co GmbH. Certification to the CE specification does not extend to, and shall be invalid for any other combination. Under no circumstances shall HANS SCHMIDT & Co GmbH be held liable for any damage resulting from the use of non-SCHMIDT sensors or cables.

2.3 Connecting the SC-PM4

2.3.1 Connecting by the USB interface



Up to 4 sensors can be connected with a PC by using the USB interface of the display unit.

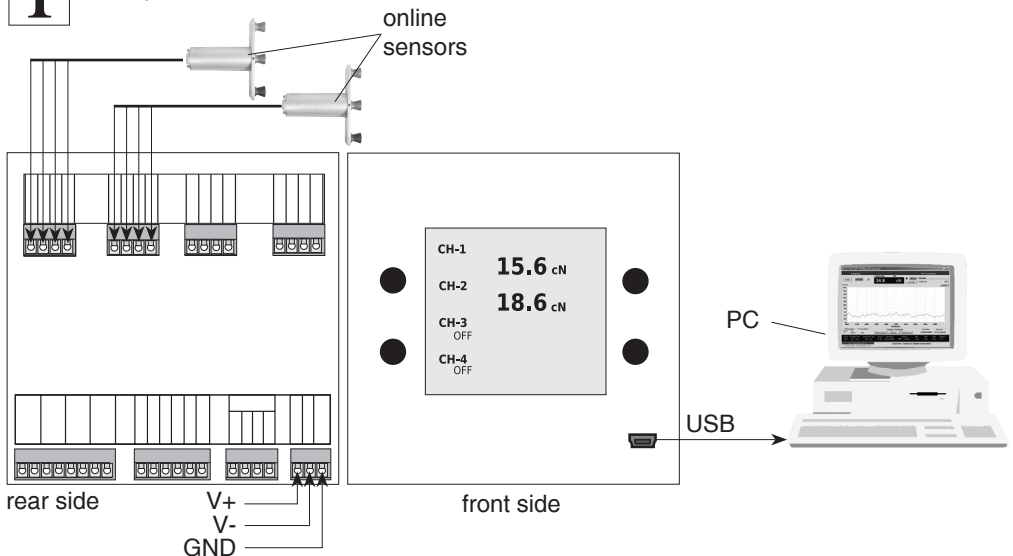

2.3.2 Connecting by the RS 422 interface

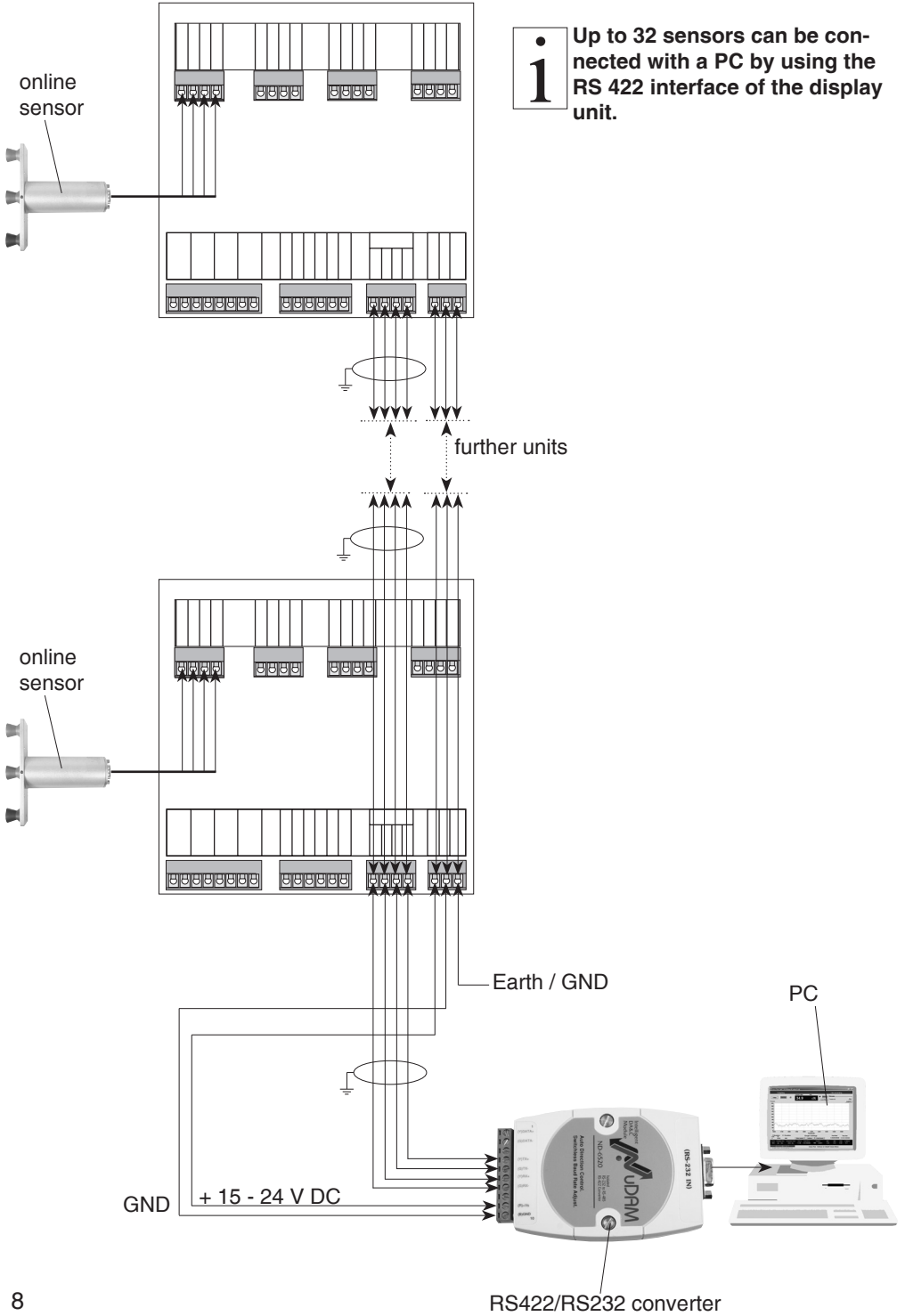

2.4 Delivery Includes

SC-PM4 display unit
USB connecting cable
1 Operating Instructions

2.5 Optional Accessories

EK0612 Connecting cable for TS sensor with 1 diode plug and open ends, length 3 m
EK0614 Connecting cable for TS sensor with 1 diode plug and open ends, length 5 m
EK0615 Connecting cable for TS sensor with 1 diode plug and open ends, length 10 m
EK0620 Connecting cable for FS sensor with 1 sub-miniatur connector and open ends, length 2 m
EK0621 Connecting cable for FS sensor with 1 sub-miniatur connector and open ends, length 5 m
EK0622 Connecting cable for FS sensor with 1 sub-miniatur angle connector and open ends, length 2 m
EK0623 Connecting cable for FS sensor with 1 sub-miniatur angle connector and open ends, length 5 m
EK0660 Connecting cable for RS 232 interface for connection to PC, length 2 m
EBK800 Converter from RS 422 to RS 232
EK0643 Connecting cable to connect the converter to PC, length 2 m
SW-TI3 Software "Tension Inspect 3" for displaying and saving readings on a PC (Win XP and higher)

2.6 Unpacking

Unpack the display unit and inspect it for any shipping damage. Notices of defect must be filed immediately, in writing, at the latest within 10 days on receipt of the goods.

3 Operation

3.1 Operating Elements

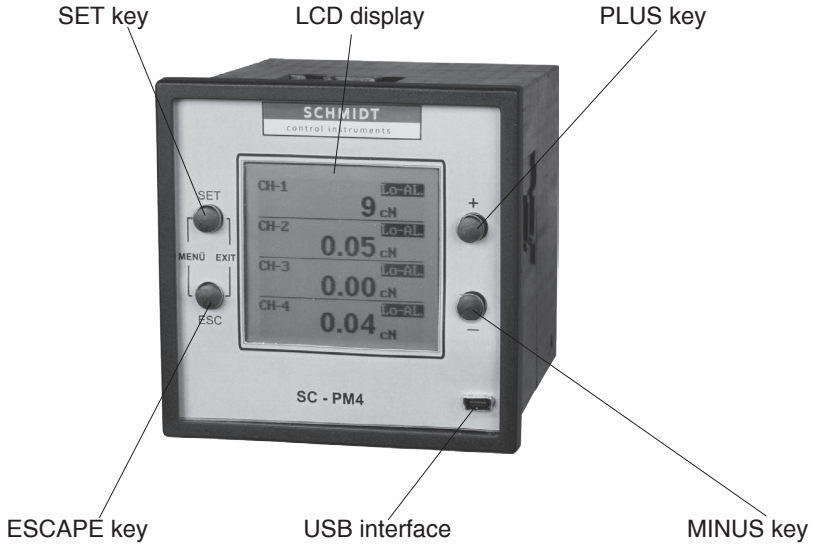

3.1.1 Switch-On

Requirements:

- Install the sensor at the desired measuring location.
- Connect the external power supply.
- Connect the SC-PM to the supplied sensor with one of the optional available cables.



In no event shall HANS SCHMIDT & Co GmbH take over any warranty coverage for, or shall be held liable for, any damage resulting from self-made cables.

To switch on the SC-PM4:

- Switch on the external power supply.

The LCD shows the model designation of the display unit, as well as software and hardware version. Afterwards the display unit changes in the measuring mode.

3.1.2 Switch-Off

- Switch off the external power supply.

3.2 Operating Procedure



Have you read and understood the Operating Instructions, in particular Chapter 1 “Basic Safety Notices”? You are not permitted to operate the device before doing so.

Before working with the device you must put on your personal protective clothing, if necessary. For example, eye protectors, gloves, etc.



The ID plate with the CE mark and the serial number as well as the calibration label (optional) and the SCHMIDT Quality Seal are provided on the surface of the instrument.

- Switch on the instrument as described in Chapter 3.1.1.
- Select the desired tension range and tension unit as described in Chapter 3.3.2. (Only necessary when using the unit for the first time or after a sensor change.)
- Allow approx. 10 minutes for thermal stabilization of the instrument.
- If the material path is other than vertical or if the process material deviates significantly from the SCHMIDT calibration material, you need to carry out **ZERO** and **GAIN adjustment** as described in Chapter 3.4.1 before starting measurement.
- Thread the process material through the measuring and guide rollers, following the red material path symbol on the front of the sensor.

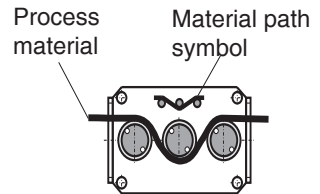

The LCD now shows 39.5 cN the measured line tension.



If the line tension drops below the low alarm limit set according to Chapter 3.3, the display shows **MIN-AL**.

If the line tension exceeds the high alarm limit set according to Chapter 3.3, the display shows **MAX-AL**.

3.3 Settings

The defaults for the display unit have been set to the requirements of the particular measurement

Requirement:

- Instrument switched on.

To change the settings:

- Press the „SET“ and „ESC“ key simultaneously to enter the main menu.
- Press the „+“ or „-“ key to select the different items in the main, sub and setting menus.
- Press set to enter the selected menu
- The settings can be chosen in the setting menu by pressing the „+“ or „-“ key. The particular digits can be interconnected and saved by pressing the „SET“ key. Quit the menu without save by pressing the „ESC“ key
- Press the „SET“ and „ESC“ key simultaneously to go back from the main menu to the measuring mode.

3.3 Settings (Cont.)

Main menu	Sub menu	Setting menu	Description
Display	—	[numeric] [Bargraph]	<ul style="list-style-type: none"> • Readings are displayed as number. • Readings are displayed as number and bar graph
Damping	—	[1 - 9]	For adjusting the damping (Kap. 3.3.1)
Alarm	—	[on], [off]	For activate or deactivate the adjusted alarm limits
CH1 - CH4 setup	Channel	[on], [off]	For activate or deactivate the measuring of the selected channel
	Cal.space	[1 - 4]	For selecting one of the 4 saved calibrations
	Hi-Alarm	[1 - 9999]	For adjusting the max. alarm limit. MAX-AL is displayed when exceeding.
	Lo Alarm	[1 - 9999]	For adjusting the min. alarm limit. MIN-AL is displayed when underrun.
	Calibration		Chapter 3.3.2
Settings	Backlite	[0 - 3]	For adjusting the light intensity
	Contrast	[1 - 10]	For adjusting the contrast
	Language	[DE], [EN]	English and german can be selected
	Password	[0000 - 9999]	The password has 4 digits.
	RS422 address	[1 - 4], [2 - 5,] up to [21 - 24]	Four sequent addresses can be selected, if several units are connected in line,

3.3.1 Calculation of the damping factor

The damping factor can be modified in 9 steps from 01 = low damping:

1 old value + 8 new values

9

to 09 = high damping:

8 old values + 1 new value

9

i The settings you made remain stored in the SC-PM4 memory even after the instrument is switched off.

Only one damping factor is adjustable for the 4 channels.

3.3.2 Sub menu calibration

Sub menu	Calibration settings	Setting menu	Description
Calibration	Name	Characters, Numbers, Special characters	To insert a name for the calibration, selected in Cal.space
	Adjust	[GAIN], [ZERO]	See chapter 3.4
	Range	[5.00], [10.00], [20.00], [50.0], [100.0], [200.0], [500], [1000], [2000]	For adjusting the tension range of the sensor that is connected to the selected channel.
	Unit	[cN], [N], [dN], [g], [kg], [oz], [lb]	For adjusting the measuring unit, the connected sensor is calibrated.
	Analog gain	[0000 - 9999]	See chapter 4

3.4 Sensor Calibration

All tension meters are calibrated with standard materials - such as polyamide monofilament (PA) - according to the SCHMIDT factory procedure; the material path is vertical. Any difference in process material size and rigidity from the standard material may cause a deviation of the accuracy. In 95% of all industrial applications, the SCHMIDT calibration has been proven to provide the best results and is used for comparative purposes. If required you can also operate the sensor with a material path other than vertical. Should the process material differ significantly from the SCHMIDT calibration material in size, rigidity or shape, we recommend special calibration using customer supplied material. If a different material path (e.g. horizontal) or special calibration using customer supplied material is required, you need to carry out static **ZERO** and **GAIN adjustment** as described in Chapter 3.4.1.



Since **ZERO** and **GAIN** adjustments are always performed statically, the readings may differ under dynamic load.

3.4.1 ZERO and GAIN Adjustment

You can save up to four different calibrations.



The calibration take always place for the material, that ist selected under Cal.Space (see chapter 3.3)

Requirements:

- Two weights, one corresponding to 10% and one to 90% of the selected tension range, must be provided. Pay attention to the selected unit of measure (cN or kg).
- Sensor installed at measuring location.
- Instrument switched on as described in chapter 3.1.1.
- Allow approx. 10 minutes for thermal stabilization of the instrument.

To carry out the calibration

- Select the calibration curve, for that the calibration should carried out (see chap. 3.3.1).
- Go to the menu item adjust (chap. 3.3.2).

ZERO adjustment:

- Thread the process material through the measuring and guide rollers, following the red material path symbol on the front of the sensor.
- Hang a weight that corresponds to 10% of the tension range from the process material, vertically, as shown in fig. 3.4.1.(Always use a fresh portion of the material to be measured.)
- Press and hold the the ESC key.
- Press the + or – key repeatedly until the tension value on the LCD is equal to the value of the suspended weight.

For example: Sensor model TS1 - 200
Weight 20 cN =

LCD display 20.0 cN

- Release the ESC key.
- The set value is saved to the calibration

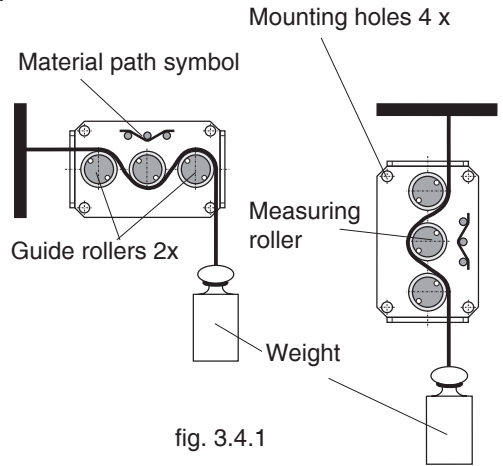

3.4.1 ZERO and GAIN Adjustment

GAIN adjustment:

Requirement:

ZERO adjustment carried out.

To carry out GAIN adjustment:

- Hang a weight that corresponds to e.g. 90% of the tension range (pay attention to the correct unit of measure) from the process material, vertically, as shown in fig. 3.4.1.
- Press and hold the SET key.
- Press the + or – key repeatedly until the tension value on the LCD is equal to the value of the suspended weight.

For example: Sensor model TS1 - 200

Weight 180 cN = Display

180.0 cN

- Release the SET key.
The set value is saved to the calibration curve
- Check the adjustments with a fresh portion of the process material and repeat the procedure if necessary.

or

- Press the SET and ESC simultaneously to quit the menu adjust to go back as described in chapter 3.3 to the measuring mode.

4 ANALOG Interfaces

The analog interface is provided for customer signal processing or for connecting a line recorder which conforms to the current industrial standard.

Please refer to Chapter 2.1 for the specifications.



CAUTION The analog interface
must be calibrated only by
qualified electrical personnel.



GAIN adjustment:

Requirement:

- Connect a volt meter to the ANALOG interface.
- Switch on the instrument as described in chapter 3.1.1.
- Allow approx. 10 minutes for thermal stabilization of the instrument.

GAIN adjustment:

- Thread the process material through the measuring and guide rollers.
- Go to the menu item "ANALOGWERT" as described in chapter 3.3.2

Adjusting

- Press the + or – key repeatedly until the display of the volt meter connected to the ANALOG interface (10 V) reads the desired value.

Check the setting and repeat the procedure if necessary.

Change to the measuring mode as described in chapter 3.3

5 Online Sensor Specifications

5.1 TS, FS and MZ Series

TS series (Models TS1, TSP, TSH, TSL, TSF, TSW, TSR, TSB1, TSB2)

FS series (Models FS1, FSP, FSH, FSL, FSB1, FSR)

MZ series (Models MAZD, MBZD, MAZF, MBZF, MBZB)

Calibration: According to SCHMIDT factory procedure

Accuracy: For 10 % to 100 % of range:

TS: ± 1 % Full Scale

FS: ± 1.5 % Full Scale

MZ: ± 2 % Full Scale Remainder of Range and

Other Calibration Material: ± 3 % full scale or better

Overload Protection: 100% of range

Measuring Principle: Strain gauge bridge

Measuring Roller Deflection: 0.5 mm max.

Signal Processing: Analog

Output Signal: 0 - 1 V DC (standard)

Damping (f_d): Standard: 30 Hz (other values on request)

Temperature Coefficient: Gain: less than ± 0.05 % full scale / °C

Temperature Range: 10 - 45 °C

Air Humidity: 85% RH, max.

Power Supply: Standard: + 15 bis + 24 V DC (21 mA, regulated)

Further technical details are provided in the Operating Instructions for the sensors.

5.2 SF Series

Models SFD, SFZ and SFK

Accuracy: 0.5 % full scale

Max. applied Force: 160 % full scale, overload protection afterwards

Overload Protection: SFZ: 10 times of nominal load, max. 3200 N

SFD, SFK: 10 times of nominal load, max. 2000 N

Lateral force at the axis: max. 100 % nominal load

Measuring Principle: Strain gauge bridge

Output Signal: SFD: 1 mV/V

SFZ: 5 - 20 N: 1 mV/V, from 50 N: 1.5 mV/V

SFK: 1.5 mV/V

Temperature Range: 10 - 70 °C

Power Supply: 10 V DC

Further technical details are provided in the Operating Instructions for the sensors.

6 Service and Maintenance

The display unit is maintenance-free.

7 Cleaning

For cleaning the unit, do not use any



AGGRESSIVE SOLVENTS

such as trichloroethylene or similar chemicals.



NO WARRANTY OR LIABILITY

shall be accepted for damage resulting from improper cleaning.

8 Correspondence

Should you have any questions regarding the instrument or Operating Instructions, or their use, please indicate above all the following details which are given on the ID plate:

- 1.) Model
- 2.) Serial number

9 Repairs

Shipping instructions:

We kindly ask for return free of charge for us, if possible by airmail parcel. All occurring charges, if any (such as freight, customs clearance, duty etc.), will be billed to customer. For return from foreign countries, we ask you to include a proforma invoice with a low value for customs clearance only, e.g. 50 Euro, each and to advise the shipment in advance by fax or eMail.



To avoid unnecessary follow-up questions, and the resulting loss of time or possible misunderstandings, please return the unit with a detailed fault description to our service department. Please indicate in your order whether you require an Inspection Certificate 3.1 according to DIN EN 10204.

Notizen:



Tension Meter



Force Gauge



Torque Meter



Tachometer



Speed- and Lengthmeter



Electronic Lengthmeter



Stroboscope



Screen Printing Tension Meter



Thickness Gauge



Yarn Package Durometer and Shore Durometer



Sample Cutter



Balance



Moisture Meter



Leak Tester



Softometer

CHECK•LINE®—PRECISION QUALITY CONTROL INSTRUMENTS

Electromatic Equipment Co., Inc.
600 Oakland Ave.
Cedarhurst, NY 11516—USA

Tel: (800) 645-4330 (USA & Canada)
Tel: (516) 295-4300
Fax: (516) 295-4399

Email: info@checkline.com
Website: www.checkline.com

For additional information or to place an order CALL TOLL FREE 1-800-645-4330

Check•Line is a registered trademark of Electromatic Equipment Company Inc.