MODEL DTS

DIGITAL TENSION METER



Operating Manual

TABLE OF CONTENTS

1.0	Introduction.....	2
2.0	Overview of Operating And Display Elements	3
3.0	Set-up	6
3.1	Charging the battery	
3.2	Turning the tension meter ON and OFF	
4.0	Tension Meter Settings	7
4.1	Procedure	
4.2	Setting chart	
4.3	Material menu	
4.4	Password	
4.5	Factory Reset	
5.0	Operation	10
5.1	Requirements	
5.2	Material thickness compensator	
5.3	Zero adjustment of the measurement position	
5.4	Inserting and removing the maaterial to be measured	
5.5	Damping	
5.6	ALARM function	
5.7	Cal. adjustment	
5.8	Peak Value	
6.0	Creating a Material Characteristic	16
6.1	Calibration procedure	
6.2	Verifying the calibration	
6.3	Memory functions	
6.4	Save data	
6.5	Displaying the saved measured values	
6.6	Deleting the saved measured values	
7.0	Specifications	21
7.1	General specifications	
7.2	Available models	
7.3	Guide rollers	
8.0	Maintenance and Cleaning	23
8.1	Maintenance	
8.2	Cleaning	
9.0	Warranty.....	24



WARNING: Tensions that exceed the tension range of the instrument by more than 100% may cause permanent damage to the measuring spring and must be avoided under any circumstances.

1.0 INTRODUCTION

The DTS is supplied as a complete kit that includes:

- (1) Tension meter with accumulator and AC adapter with country adapters (EU, US, UK)
- (1) Certificate of compliance with the order 2.1 under EN 10204
- (1) Operating Instructions
- (1) Carrying case

NOTE: Unpack the tension meter and inspect it for shipping damage. Notices of defect must be filed, in writing, at the latest within 10 days on receipt of the goods.

2.0 OVERVIEW OF OPERATING AND DISPLAY ELEMENTS

FIG. 1

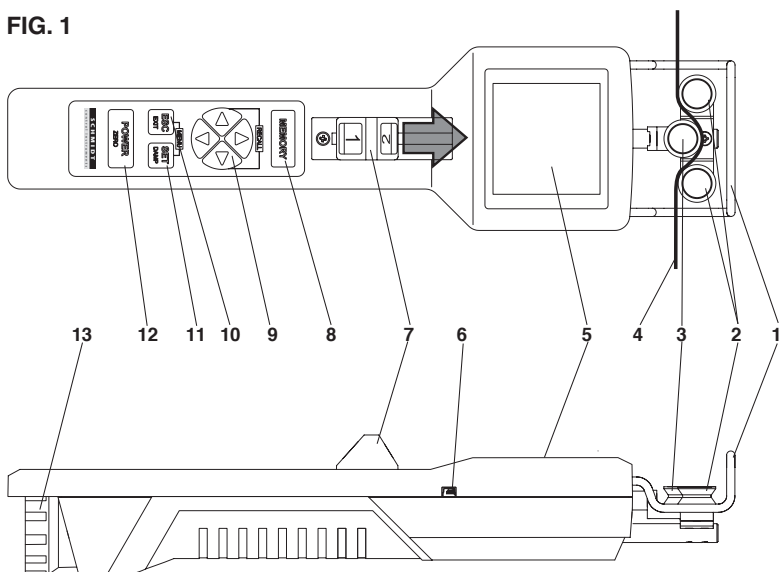

- 1. Filament guide
- 2. Guide rollers
- 3. Measuring roller
- 4. Material to be measured
- 5. Display
- 6. USB interface / power connector
- 7. Thumbpiece
- 8. MEMORY key
- 9. Arrow key
- 10. ESC / EXIT key
- 11. SET / DAMP key
- 12. POWER / ZERO key
- 13. Adjustment wheel for material thickness compensator
(subject to model or measuring range, otherwise a cover cap is provided)

Numeric display

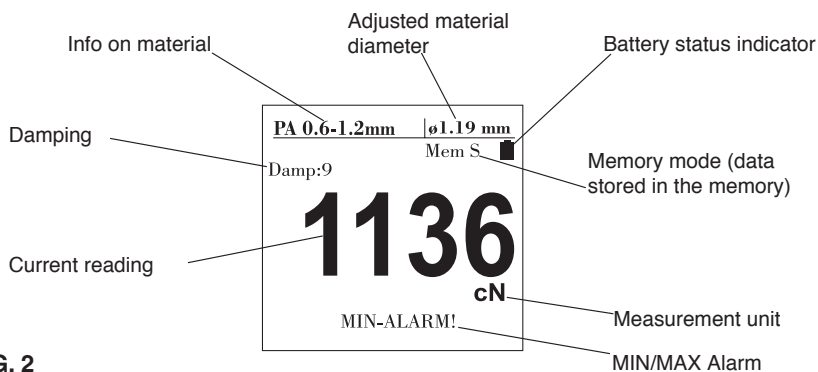

FIG. 2

Display with Bargraph

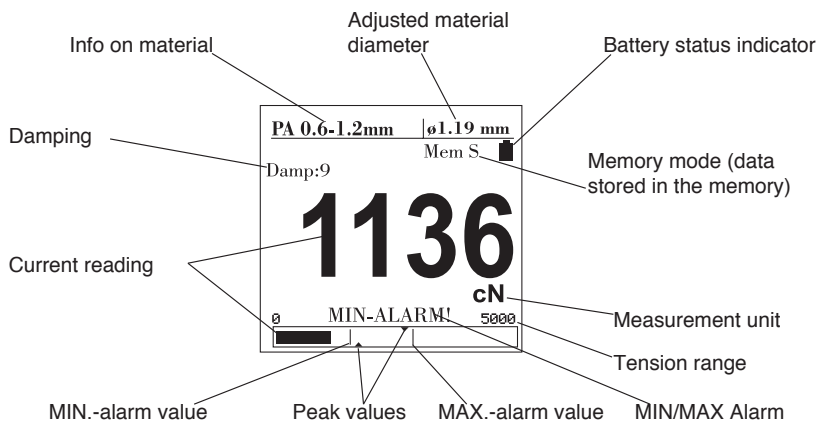

FIG. 3

Graphic display

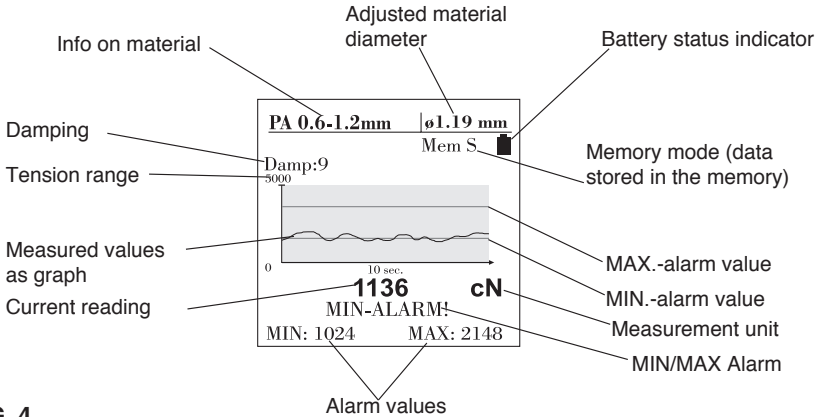

FIG. 4



The Y-axis can be scaled with the ▲ and ▼ buttons.

3 Scalings: total measuring range, set limits range plus approx. 1/3 of MAX.-alarm value and minus approx. 1/3 of MIN.-alarm value, set limits range.

The scaling is only possible, if limit values are entered and the damping is not activated.

With the ◀ or ▶ button the X-axis can be scaled. The setting range is 0.5 to 60 sec.

The scaling can also be changed during the measurement, whereby values already displayed are deleted when the X-axis is changed.

3.0 SETUP

The tension meter is delivered with a built-in rechargeable LiPo battery, which has been charged at the factory. The tension meter can only be switched on if the battery is still working, i.e. if the battery has enough charge. If the instrument does not power up or if the battery level indicator shows only one bar  after power-up switching the tension meter on, the battery needs to be recharged.

NOTE: To ensure maximum battery life, avoid discharging the battery completely or charging it frequently for short periods. The battery should not be stored for an extended period of time when empty. After a maximum storage period of one year, the battery has to be recharged.

3.1 Charging the Battery

To charge the battery, connect the cable of the AC adapter to the low USB output. The battery can also be charged by connecting the USB cable to a PC. When the battery is fully charged, the battery level indicator will show 5 bars . The charging time is approx. 3 ½ hours (using the AC adapter).

NOTES: It is not possible to overcharge the battery. The battery can only be charged at a temperature between +5 °C and +45 °C. Before you connect the AC adapter, verify that the supply voltage is correct (100 V – 240 V).

3.2 Switching the tension meter ON and OFF

To switch ON

Press and hold the  button (for approx. 1 sec.) until the DISPLAY shows the measuring range, the software and hardware versions, e.g. E 1.0, and then “0”. During startup, the tension meter performs an automatic zero adjustment (see Section 5.3).

Holding the  button makes the display freeze so that you can read the measuring range and the software and hardware versions.



While switching on the tension meter, make sure not to move it. This will cause the automatic zero adjustment to be faulty

To switch OFF

Automatic Switch Off : After 3 minutes of non-use the tension meter will switch off.

Manual Switch Off : Press and hold the  button for five seconds.

4.0 TENSION METER SETTINGS

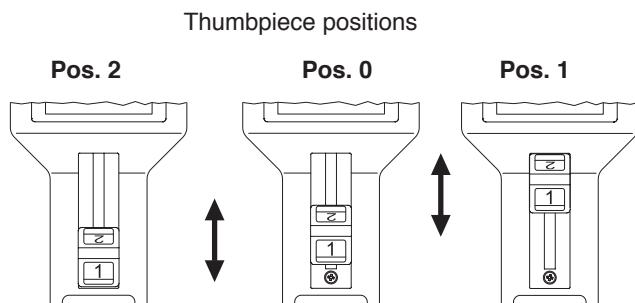

FIG. 5

2 = Measurement position













0 = Adjustment position

1 = Threading position (guide rollers in their forward position)



Menu settings can be changed with the thumbpiece in Pos. 0 (Adjustment position). To perform measurements the thumbpiece must be in the measurement position (Pos. 2).

4.1 Procedure

1. Press the  and  buttons simultaneously to access the main menu.
2. The  and  buttons can be used to select the various menu items of the main menu, the submenus and the settings menus.
3. Press the  button to open the selected menu; by pressing the  or  button you can close the menu without saving changes.
4. In menus with multi-digit fields (e.g. date) use the  and  buttons to move forward and backward between digits.
5. Press the  button to save the settings and exit the settings menu or press the  button to exit the current menu without saving.
6. To exit the main menu press the  button.

4.2 Tension Meter settings chart

Main Menu	Submenu	Settings Menu	Description
Material	[1] to [11]		Section 4.3 Material set up
Cal. Adjustment	—	[-10%] – [+10%]	Section 5.7
Display Section 6.5	—	[numeric] [Bargraph] [Graphic]	<ul style="list-style-type: none"> Measured value displayed as number and alarm monitoring Measured value displayed as number, bar graph trend display and alarm monitoring Measured value displayed as graphical trend, measured value/limit values as numbers
Alarms	—	[ON] , [OFF]	Activate/deactivate the alarm for all calibrations. The alarm of a material characteristic is only active if the [Alarm] menu item in Material Setup is activated as well.
Peak Display		[ON], [OFF]	Activate/deactivate the peak values in the bar graph display.
Settings	Tension Unit	[cN] , [N], [lb], [g], [kg]	Set the measurement unit. The available units may vary depending on the measuring range of the device.
	Diameter Unirt	[mm] , [inch]	To select between mm and inch.
	Contrast	[0] – [10]	To adjust the contrast
	Backlight	[ON], [OFF], [AUTO]	Switch the display light on or off. With the AUTO setting, the light switches on and off automatically depending on the ambient light.
	Brightness	[1], [2] , [3]	Set the display brightness
	Screen Rotation	[0°], 90°, [180°], [270°], [AUTO]	To set the display orientation to be fixed or to automatically adapt to the current orientation of the device.
	Auto Power Off	[ON] , [OFF]	Toggle the AUTO POWER OFF function on and off
	Language	[EN] , [DE]	Select English or German user language
	Date/Time	[Time], [Date], [Time Format]	Set the time, date, and date/time format
	Password	[0000], [9999]	Section 4.4
Factory Reset		Reset to the factory settings	

Factory settings are in bold text.

4.3 Material Menu

In the material menu you can make the settings for the selected material characteristics and perform the calibration. To perform the calibration, the weights for the selected calibration points must be available.

Material Setup	Submenu	Settings Menu	Description
No. of the characteristic-material curve 1 - 5	—	[character], [numbers], special character]	To enter a name for the selected material characteristic.
Damping	—	[1] - [9]; [5]	Section 5.5
Alarms	—	[ON], [OFF]	To activate or deactivate the alarm function for the material characteristic.
High Limit	—	[0000] - [9999]	Activate/deactivate the alarm for all calibrations. The alarm of a material characteristic is only active if the [Alarm] menu item in Material Setup is activated as well.
Low Limit		[0000] - [9999]	Activate/deactivate the peak values in the bar graph display.
Calibration 6.1	Start		To perform a calibration, follow the instructions shown on the display.
	Cal. Points	between [10 %] and [100 %] of the tension range	Set three calibration points for which a calibration should be performed.
	Weights	[cN/daN] [g/kg]	Set the unit of the calibration weights used.

4.4 Password

Setting a password blocks the access to some menu parts for unauthorized users:

- 0000 All menus are accessible.
- 0001 – 0999 The Material, Cal. Adjustment, Settings, and Memory Settings menus are locked
- 1000 – 9999 The entire menu is locked.

NOTE: To apply a changed password, exit the main menu. Entering 0000 as the password disables the password feature. If you forgot the password, please contact the factory to request the master password. As an alternative, you can perform a factory reset. Please note, that in this case, you will lose any customer-defined calibrations.

4.5 Factory Reset

A factory reset resets the tension meter to its original manufacturer settings. This procedure will delete all settings, including any customer-defined material characteristics (calibrations); the factory calibration, however, will be kept.

Customer calibrations will be deleted.



5.0 OPERATION

5.1 Requirements

1. Switch the tension meter on (Section 3.2)
2. Define the required tension meter settings (Section 4.2)
3. Select the desired material characteristic (Section 4.3)
4. Set the material thickness compensator (Section 5.2), if equipped
5. Bring the tension meter into the desired measuring position and carry out a zero adjustment as described in Section 5.3, if required.

5.2 Material thickness compensator (only for devices with a thumbwheel)

The 3-roller-system for tension measurement relies on the displacement of the middle roller (measuring roller) to give an indication of the line tension. As the material thickness changes, there will be a change in the tension reading, even when the line tension has not changed. To compensate for this effect, high-range instruments are usually equipped, as necessary, with a material thickness compensator, which automatically shifts the outer rollers. To adapt the tension meter to the diameter of the material to be measured, push the thumbpiece into the adjustment position “0” (Section 4.0) and pull the thumbwheel of the material thickness compensator backward to the adjustment position (Figure 6). Turn it clockwise or anti-clockwise until the desired diameter, such as , appears in the upper right part of the display. Then push the thumbwheel of the material thickness compensator back to the measurement position (Figure 6). If you set a diameter that has not been calibrated for the selected material characteristic, the set diameter is displayed with a black background, e.g., the tension meter can be used anyhow, but please note, that depending on the material to be measured, slight deviations in the measured values might occur.

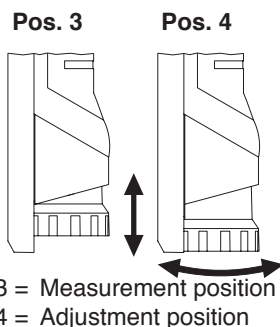

FIG. 6



If you rotate the thumbwheel while the thumbpiece is in position 2 (measuring position Figure 1), the reading on the display will be updated, but the value will not be used by the instrument to determine the tension—false measurement! The maximum material thickness you can set is 2.50 mm. Setting a higher diameter can damage the tension meter.

5.3 Zero adjustment of the measurement position

Each time the measurement position is changed, the tension meter will automatically perform a zero adjustment.

If the tension meter does not display zero in its measuring position, perform a manual zero adjustment procedure. For this purpose, no material to be measured must have been inserted yet!

Requirements:



1. The tension meter has been switched on as described in Section 3.2.

To carry out zero adjustment:

1. Bring the tension meter into the desired measuring position and make sure not to move it.

2. Press the  button.



The DISPLAY momentarily shows  and then switches to . The tension meter is now adjusted to its new measuring position and ready to take measurements.

5.4 Inserting and removing the material to be measured

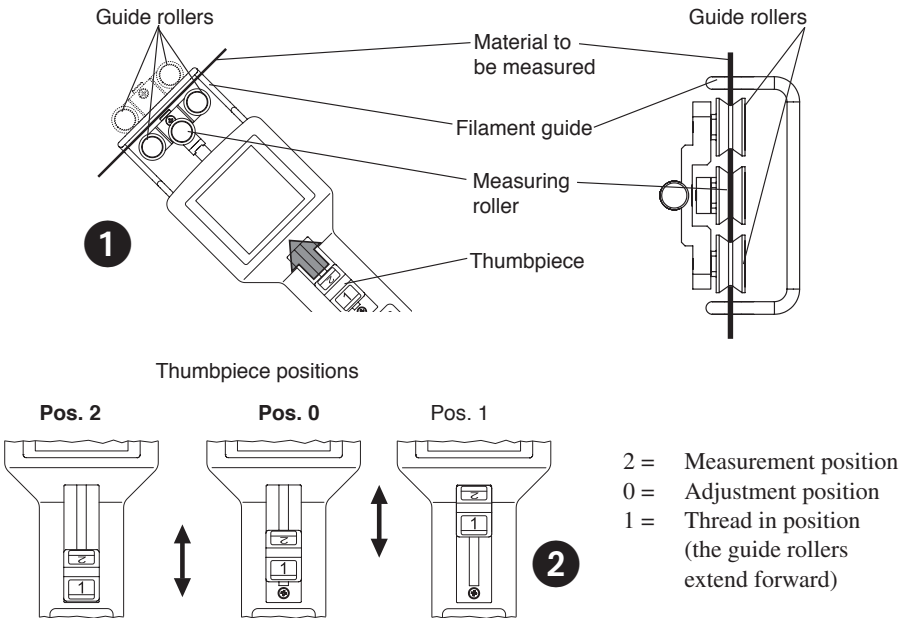

To insert the material to be measured:

1. Push the thumbpiece in the direction of the arrow into its threading position 1 (❶) until the outer guide rollers extend beyond the filament guide.
2. Position the material to be measured into the tension meter in such a way that it contacts the Filament guide and passes between the outer rollers and the middle measuring roller (❶) .
3. Slowly move the thumbpiece back into the adjustment position (❷) . It is important to ensure that the material to be measured runs smoothly between the measuring roller and the guide rollers.
4. Push the thumbpiece into the measuring position (2) (❷)
5. The display shows the measured tension value.



If the thumbpiece is not in position 2, a corresponding message is issued on the display. If the thumbpiece is not locked, faulty measurements might result.

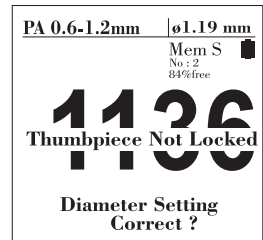

FIG. 7



Numerical Display

FIG. 8



Display with bargraph

FIG. 9

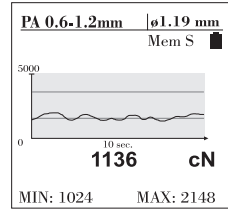

Graphical Display

FIG. 10

6. Press the ▲ and ▼ button simultaneously to change the different display modes during the working mode.



Do not let the thumbpiece snap back as this could affect the calibration and damage the instrument.

While measuring the thumbwheel of the material thickness compensator must be set to the measurement position, so that the material diameter is not altered inadvertently.

If you rotate the thumbwheel while the thumbpiece is in position 2 (measuring position), the reading on the display will be updated, but the value will not be used by the instrument to determine the tension – false measurement!

To remove the material to be measured:

1. Push the thumbpiece in the direction of the arrow into its threading position (1) (2).
2. Remove the material to be measured.
3. Slowly set back the thumbpiece into the adjustment position (0) (2).

5.5 Damping

Feature to be used for tensions that vary strongly. In the Damping menu (Section 4.3) you can specify separate damping factors for each material characteristic. Back in the display mode, press the **SET** button to activate or deactivate the damping function. This is recommended if the displayed values vary strongly. Press the button ▲ to increase the damping value or the ▼ button to decrease it.

NOTE: Changes made to the damping factor using the arrow keys are not saved permanently in the material characteristic. If you disable the damping feature or select a different material characteristic, the damping factor will be reset to the value originally saved for the material characteristic.

The factory setting for the damping factor is 5. The average shown on the display is calculated as follows:

$$\frac{5 \text{ old measured values} + 4 \text{ new measured values}}{9}$$

Damping can be changed in 9 steps from 01 = low damping:

$$\frac{1 \text{ old measured value} + 8 \text{ new measured values}}{9}$$

to 9 = high damping:

$$\frac{8 \text{ old measured values} + 1 \text{ new measured value}}{9}$$

5.6 Using the ALARM function

Requirements

In the Material Setup menu, make sure that the MIN and MAX limit values have been set for each material characteristic.

The limit value alarm can be enabled in the main menu.

5.7 Cal. adjustment

By performing a calibration adjustment, you can adjust a material characteristic calibrated for a particular material to a different material or diameter without creating a new material characteristic.

Requirements

1. Prepare the measuring setup as shown in Fig. 11
2. Make sure that the thumbpiece is in the adjustment position (Section 5.4).
3. Set the material thickness as described in Section 5.2.
4. Select the desired material (Section 4.3).
5. Move the tension meter into the desired measuring position and carry out a zero adjustment, if required.

Adjusting

1. Select the **Cal. Adjustment** menu item from the main menu (Fig. 12)
2. Insert the material to be measured (Section 5.4) and push the thumbpiece into the measuring position.

3. Press the ▲ or ▼ key to perform the calibration adjustment until the value on the display corresponds to the weight suspended to the material. The adjustment can be performed in 1 % steps within the range from + 10% to -10%.

4. Press the  button to save the determined value.

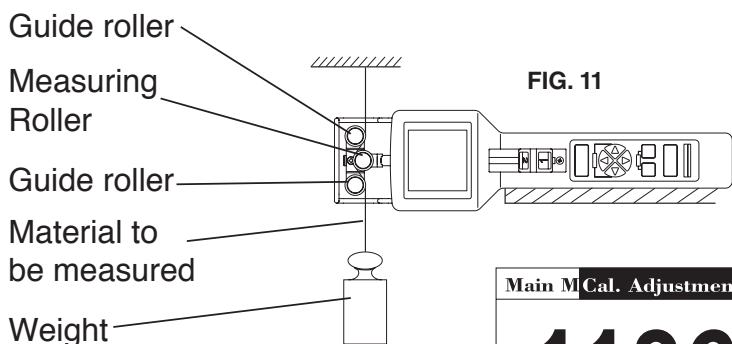

FIG. 11

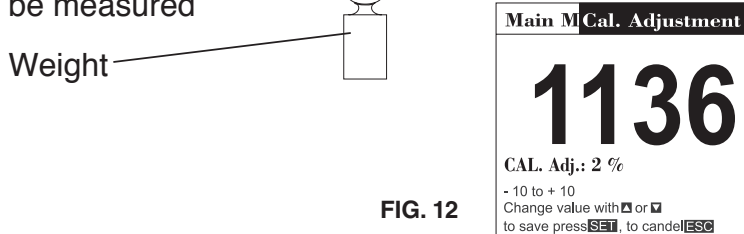

FIG. 12

NOTE: Please note that this is a general value. So determine it separately for each material characteristic and note it down for later reference. It is not possible to save it per material characteristic.

To disable calibration adjustment, reset the value to 0% in the **Cal. Adjustment** menu.

5.8 Peak value

During a measurement cycle, the tension meter automatically calculates the Peak Minimum and Peak Maximum values. If these values should not be displayed in the bar graph or in the statistics, disable their display in the main menu. Regardless, the Peak values will be used and shown always in the software **Tension Inspect 3**.

6.0 CREATING A MATERIAL CHARACTERISTIC

The tension meter has been calibrated on material 1 according our factory procedure for a vertical material path and cannot be deleted or overwritten. The the materials and diameters are given in Section 2. Factory calibrations using customer supplied materials follow the same procedure. In this case, however, the calibration on Schmidt material 1 is omitted

NOTE: The material characteristics 1 has been preset in the factory and cannot be overwritten. For these material characteristic, you can only change the damping factor, the alarm function setting, and the limit values.

6.1 Calibration procedure

Calibrations of the tension meter are performed according to the factory procedure using weights that correspond to 10%, 50%, and 90% of the measuring range. In 95% of all industrial applications, the factory calibration has been proven to provide the best results. In particular, it is suitable for comparative purposes. If the material to be measured differs significantly from the factory calibration material in material type, diameter, rigidity, shape, etc., we recommend to perform a calibration using customer-supplied material. In addition to the two factory-preset materials, you can save up to 9 additional materials.

NOTE: The material thickness unit used for the calibration is the same as currently selected in the **Settings menu**. It is not possible to overwrite the factory calibrations.

Calibration Units and Calibration Points

- You can select Newton or Kilogram as the unit of the calibration weights.
- For the calibration of the tension meter, three calibration weights are used. For example, if you select 10%, 40%, 70% for the calibration, the weights must correspond to 10%, 40%, and 70% of the measuring range.

In this example, you need the following weights for the DTX-1000:

Calibration in Newton: 100 cN, 400 cN, and 700 cN

Calibration in Kilogram: 100 g, 400 g, and 700 g

NOTE: The measured values are displayed in the unit set in the **Settings menu**, independent from the unit that was used to calibrate the material characteristic.

So that they are available when you verify the calibration later or repeat the calibration after a factory reset.

Material to be measured	Unit	Calibration points	Ø 1	Ø 2
Steel wire	cN	10%, 30%, 50%	0.4 mm	0.6 mm

Requirements:

1. The thumbpiece must be in the adjustment position(4) (Fig. 6).
2. The material thickness compensator (if existing) must be set to the adjustment position (Section 5.2)
3. The unit for the material thickness must have been set (Section 4.3)

To perform the calibration procedure:

1. Select a new material or edit an existing one (by re-entering the values) from the **material** menu.
2. Enter a designation (you can use the software supplied with the tension meter alternatively).

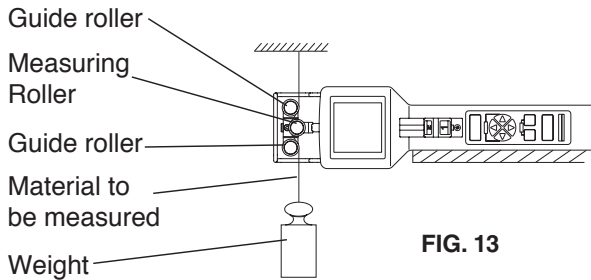
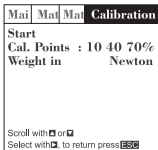

FIG. 13

NOTE: While performing the calibration, the tension meter must be fixed in such a way that the material to be measured runs smoothly between the guide rollers and the measuring roller. The display gives detailed information on the calibration.



In the **Material** menu, select **Calibration**

Step 1:

Set the calibration points and weights, e.g. in Newton using the calibration points 10%, 50%, and 90% of full scale

Start: Select the Start menu item.

Alternative calibration points:

10%, 40%, 70%	10%, 30%, 60%
10%, 30%, 50%	10%, 20%, 40%
10%, 40%, 90%	10%, 60%, 90%
10%, 60%, 100%	

We recommend to use the 10%, 50%, 90% setting for an initial calibration. If the measured values are not accurate enough when you check the calibration, repeat the calibration using other calibration points. We recommend that you align the middle of the tension range to be measured with the middle calibration point.

Mai	Mat	Mat	Calibration
Diameter 1			
0.66 mm			
Adjust diameter to material thickness to save press ESC to return ESC			

Step 2:

Set the diameter

This step is only required for tension meters with a material thickness compensator

Mai	Mat	Mat	Calibration
Zeropoint			
4472			
Place instrument to, cal. pos., wait for stable readings to save press ESC to return ESC			

Step 3:

Perform a zero adjustment with the tension meter in its measuring position

Mai	Mat	Mat	Calibration
Point 1: 10% Diameter 1 Weight: 100 eN 4665			
Insert sample, hang weight 1 wait for stable readings to save press ESC to return ESC			

Step 4:

Calibrate calibration point 1
Insert material to be measured

Mai	Mat	Mat	Calibration
Point 2: 40% Diameter 1 Weight: 400 eN 4783			
hang weight 2 wait for stable readings to save press ESC to return ESC			

Step 5:

Calibrate calibration point 2

Mai	Mat	Mat	Calibration
Point 3: 70% Diameter 1 Weight: 700 eN 5012			
hang weight 3 wait for stable readings to save press ESC to return ESC			

Step 6:

Calibrate calibration point 3

Mai	Mat	Mat	Calibration
ESC to save and exit SET to continue with second diameter			

Step 7:

Exit the calibration process or calibrate a second diameter. In this case, continue with step 2.

NOTE: By calibrating a second diameter, you can define a material thickness range to be used for the material, e.g. 0.1 – 0.3 mm. Therefore the tension meter can be used for a diameter range instead of a specific diameter only.



Once you have completed the calibration, make sure to verify it as described in Section 6.2. In case of a large deviation, repeat the calibration or select different calibration points.

6.2 Verifying the calibration

When verifying the calibration, make sure to select the same material, calibration position and calibration points as used for creating the associated material characteristic. Otherwise, the precision of the measurements will not be sufficient. The tension meter has been calibrated on material 1 according our factory procedure for a vertical material path and cannot be deleted or overwritten. The diameters and materials are given in Section 7.2. Calibrations of the tension meter are performed according to the factory procedure using weights that correspond to 10%, 50% and 90% of the measuring range.

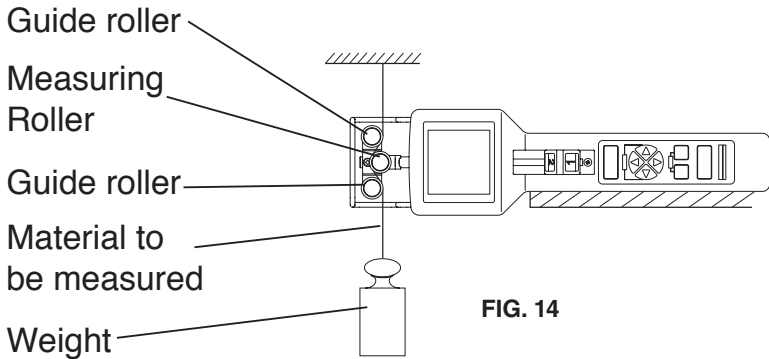

FIG. 14

1. Attach a weight vertically to the material to be measured that corresponds to the tension to be measured (make sure to select the correct unit). The weight must hang freely. (Always use a fresh portion of the material to be measured.)
2. Insert the material as described in Section 5.4



Do not let the thumbpiece snap back as this could affect the calibration and damage the instrument.

3. Before verifying the calibration, move the instrument slowly up and down to compensate for any mechanical friction losses and thus ensure repeatability of the measurements.
4. The tension value shown on the display should be equal to the mass of the suspended weight.

If the verification of the calibration shows a deviation beyond the allowable tolerance so that reliable operation is no longer possible, the instrument needs to be re-calibrated or returned to the factory for repair.

6.3 Memory functions

You can store and display the statistics of one measuring series (last measured value, the average, the minimum and maximum measured values, the peaks, the standard deviation).

Data is recorded during a user-defined period.

6.4 Save data

1. Press the **MEMORY** button to start recording the measured values.
2. While recording is in process, “Rec S” flashes on the display.
3. Press the **MEMORY** button again to stop recording.
4. To save the recorded data, press the **SET DAMP** button (the display shows “Mem S”). Data, stored in the memory before, will be overwritten.
5. Press the **ESC EXIT** button to stop recording the measured values without saving

NOTE: To abort data recording, press the button. This stops the procedure. No data will be saved.



FIG. 15

6.5 Displaying the saved measured values

1. Press the **Recall** ◀ and ▶ buttons simultaneously to display the saved data.

The display will only show statistical values	
Name of the material to be measured	MIN.
Date and time of the measurement series	PEAK max.
Last reading	PEAK min.
Average	Standard deviation (Std. Dev.)
MAX.	Number of measured values

6.6 Deleting the saved measured values

If data is saved in the tension meter, the display shows “Mem” .

Deleting data:

1. Press the **Recall** ◀ and ▶ buttons
2. Then press the **Power ZERO** button and confirm with the **SET DAMP** button.

This clears the memory.

7.0 SPECIFICATIONS

7.1 General Specifications

Calibration	According factory procedure
Accuracy	For PA from 5 % up to 100 % full scale: ± 0.5 % full scale ± 1 digit remaining tension range and other calibration materials: ± 3 % FS* ± 1 digit
Memory for material curves	1 factory calibration plus 4 for customized calibrations
Measuring units	Force (switchable): cN, daN, g, kg, N, lb Thickness (switchable): mm, inch
Overrange	Approx. 10 % full scale, full scale, without accuracy guarantee
Overload protection	100% full scale
Measuring principle	Strain guage bridge
Measuring roller deflection	Max. 0.2mm
Signal processing	Digital
Measuring frequency	Max. 1 kHz (1000 measuements/sec.), internal 8 kHz
Display	Graphic LCD display 3 different displays: numeric, numeric with bargraph, X-Y-diagramm (time-tension)
Display update time	2/sec (Display update)
Memory	MIN, MAX, PEAK, AVG and LAST
Damping	Adjustable electronic damping (averaging)
Cal. adjustment	± 10 steps in 1% increments
Thickness compensation	Max. 2.5 mm (not available for all models)
Auto power off	Approx. 3 minutes of non-use
Signal processing	16 bit A/D
Temperature coefficient	Gain: less than ± 0.01 % full scale* /°C at 25° C Zero point: better than ± 0.3 % full scale* /°C at 25° C
Temperature range	10 to 45° C

Continued on next page

Air humidity	85% RH, max
Power supply	LiPo Accumulator (approx. 40 hours continuous use, charging time approx. 3.5 hours)
Housing material	Die-cast aluminum
Housing dimensions	265mm x 78.5 mm x 46 mm (L x W x H)
Weight (net/gross)	Up to DTS-50K approx. 875 g / 1550 g DTS-60K-V1 approx 1040 g / 2700 g

7.2 Available models

Model	Tension Ranges cN	*Measuring Head Width mm	**Factory Calibration Material 1 Polyamide [PA] Monofilament	***Material Thickness Compensator for Included
DTS-200	0.2 - 200.0	66	0.12 mm Ø	
DTS-500	0.5 - 500.0	66	0.12 + 0.20 mm Ø	yes
DTS-1000	10 - 1000	66	0.20 + 0.40 mm Ø	yes
DTS-2000	20 - 2000	66	0.40 + 0.70 mm Ø	yes
DTS-2500	25 - 2500	116	0.40 + 0.70 mm Ø	yes
DTS-4000	40 - 4000	66	0.50 + 0.80 mm Ø	yes
DTS-5000	50 - 5000	116	0.60 + 1.20 mm Ø	yes
DTS-10K	0.1 - 10.00 daN	116	0.80 + 1.40 mm Ø	yes
DTS-20K	0.2 - 20.00 daN	116	1.20 + 1.80 mm Ø	yes
DTS-30K	0.3 - 30.00 daN	216	1.40 + 2.00 mm Ø	yes
DTS-50K	0.5 - 50.00 daN	216	steel rope 1.5 mm Ø (7 x 7 x 0.15)	
DTS-60K-V1	0.6 - 60.00 daN	280	steel rope 2.0 mm Ø (7 x 7 x 0.30)	

International unit of tensile force: 1 cN = 1.02 g = 0.01 N, 1 daN = 1.02 kg = 10.0 N

- * Depending on model, either width of filament guide or outer distance between outside guide rollers
- ** Suitable for 95 % of all applications. PA = Polyamide Monofilament. If the material to be measured differs significantly from the SCHMIDT calibration material in diameter, rigidity, shape, etc., we recommend calibration using customer supplied material.
Instruments with calibration on customer sample are not adjusted and calibrated on material 1.
- *** The DTSB, DTSE, DTSF and DTSL models do not include a material thickness compensator. They are calibrated only on material 1.

The DTSB is calibrated depending to the range on a textile ribbon or thin tape.

7.3 Guide Rollers

V-grooved	Line Speed max. m/min	Roller Material
Standard	2000	Hard-coated aluminium
Standard	4000	Hardened steel only for DTXL
Code K	3500	Hard-coated aluminium
Code H	5000	Plasma-coated aluminium
Code T	1000	Plastic (POM) black
Code T	4000	Plastic (PVC) red only for DTSF
Code W	1000	Nickel-plated steel
Code ST	1000	Hardened steel
Code B	1000	Tempered steel for measuring tire cord
Code CE2	1000	Ceramic-coated aluminium
Asymmetrical groove Code ASY	1000	Hard-coated aluminium (not for DTS-200)
Code ASYB	1000	Tempered steel for measuring tire cord (not for DTS-200)
Code V1	1000	Hard-coated aluminium (only for DTS-60K-V1)
U-grooved Code U	2000	Hard-coated aluminium(not for DTS-200)
Code R1	4000	Hard chrome-plated steel (radius R5)only for DTSL

8.0 MAINTENANCE AND CLEANING

8.1 Maintenance

The tension meter is easy to maintain. Depending on operating time and load, the instrument should be checked according to the locally valid regulations and conditions. The use of other test methods than the procedure described in Section 5.0 may cause deviating measuring results.

Rollers

You should regularly inspect the rollers to assure that they are running easily and smoothly. You can replace the rollers yourself, as necessary. Please indicate the tension meter model and the serial number (given on the rear side of the tension meter) in your spare-parts order.

For example, To order spare rollers:

Model: DTS-1000 (given on rear side of tension meter)

Serial number: 920 - 888888 (given on rear side of tension meter)

Standard rollers: Model number R592004

Delivery: 1 set (3 pcs.) of spare rollers 2000 m/min, incl. mounting tool

or

Model: DTS-1000-K (given on rear side of tension meter)

Serial number: 920 - 888888 (given on rear side of tension meter)

Code K rollers: Model number R592003

Delivery: 1 set (3 pcs.) of spare rollers 3500 m/min, incl. mounting tool

8.2 Cleaning

For cleaning the unit do not use any **AGGRESSIVE SOLVENTS** such as trichloroethylene or similar chemicals. **NO WARRANTY OR LIABILITY** shall be accepted for damage resulting from improper cleaning.

9.0 WARRANTY

ELECTROMATIC Equipment Co., Inc. (ELECTROMATIC) warrants to the original purchaser that this product is of merchantable quality and confirms in kind and quality with the descriptions and specifications thereof. Product failure or malfunction arising out of any defect in workmanship or material in the product existing at the time of delivery thereof which manifests itself within one year from the sale of such product, shall be remedied by repair or replacement of such product, at ELECTROMATIC's option, except where unauthorized repair, disassembly, tampering, abuse or misapplication has taken place, as determined by ELECTROMATIC. All returns for warranty or non-warranty repairs and/or replacement must be authorized by ELECTROMATIC, in advance, with all repacking and shipping expenses to the address below to be borne by the purchaser.

THE FOREGOING WARRANTY IS IN LIEU OF ALL OTHER WARRANTIES, EXPRESSED OR IMPLIED, INCLUDING BUT NOT LIMITED TO, THE WARRANTY OF MERCHANTABILITY AND FITNESS FOR ANY PARTICULAR PURPOSE OR APPLICATION. ELECTROMATIC SHALL NOT BE RESPONSIBLE NOR LIABLE FOR ANY CONSEQUENTIAL DAMAGE, OF ANY KIND OR NATURE, RESULTING FROM THE USE OF SUPPLIED EQUIPMENT, WHETHER SUCH DAMAGE OCCURS OR IS DISCOVERED BEFORE, UPON OR AFTER REPLACEMENT OR REPAIR, AND WHETHER OR NOT SUCH DAMAGE IS CAUSED BY MANUFACTURER'S OR SUPPLIER'S NEGLIGENCE WITHIN ONE YEAR FROM INVOICE DATE.

Some State jurisdictions or States do not allow the exclusion or limitation of incidental or consequential damages, so the above limitation may not apply to you. The duration of any implied warranty, including, without limitation, fitness for any particular purpose and merchantability with respect to this product, is limited to the duration of the foregoing warranty. Some states do not allow limitations on how long an implied warranty lasts but, notwithstanding, this warranty, in the absence of such limitations, shall extend for one year from the date of invoice.

ELECTROMATIC Equipment Co., Inc.
600 Oakland Ave. Cedarhurst, NY 11516—USA
Tel: 1-800-645-4330/ Tel: 516-295-4300/ Fax: 516-295-4399

Every precaution has been taken in the preparation of this manual. Electromatic Equipment Co., Inc., assumes no responsibility for errors or omissions. Neither is any liability assumed for damages resulting from the use of information contained herein. Any brand or product names mentioned herein are used for identification purposes only, and are trademarks or registered trademarks of their respective holders



ELECTROMATIC
E Q U I P M E N T C O . , I N C .

600 Oakland Ave., Cedarhurst, NY 11516 – USA
TEL: 516-295-4300 • FAX: 516-295-4399