

TBIH (Small Break-Over Wrench) Operating Instructions

Rev 2.2 (1/30/2017)

Ref. Item # 500293

TBIH “Break-Over” Wrenches

These small production wrenches ‘break-over’ once reaching preset torque setting. Compact and well balanced, these wrenches can adapt to a variety of different “head” styles.

Calibrating Torque Wrenches

To calibrate torque wrenches either use a torque tester or torque sensor within the range of the torque wrench. For break-over torque wrenches calibrate torque in “Peak” mode with a digital torque tester or torque sensor. Make sure to apply the torque slowly and smoothly at the “Load Point Line” near end of the handle.

1. Select a torque tester or torque sensor that covers the torque range of the TBIH wrench. Connect wrench to the torque tester or torque sensor using the appropriate adapters as needed (not supplied).
2. Apply torque clockwise slowly until wrench ‘breaks-over’ and note reading.
3. Adjust wrench to required torque setting as described below.
4. Test and repeat adjustment as necessary to obtain desired value.
5. Recalibrate torque wrench at prescribed intervals.

Adjusting Torque Setting

1. Remove plastic end cap from the handle.
2. Insert 3/16 hex key into adjusting screw and turn clockwise to increase torque and counter clockwise to decrease torque. Verify the torque setting using a torque tester or torque sensor. Do not adjust torque setting above or below the recommended torque ranges of the wrench. Place end cap back on.

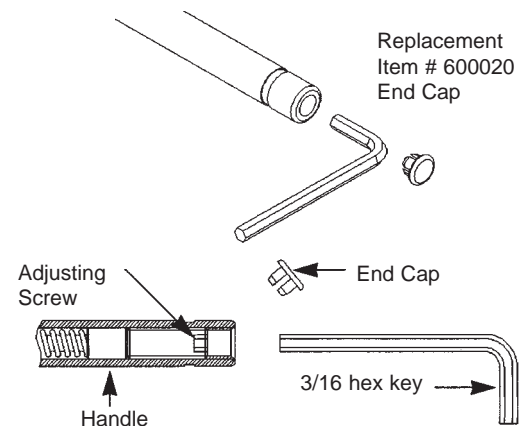

Placing Heads on Wrench

1. Loosen set screw along the collar near handle head with 5/64 hex key. Slide head into head slot and tighten with hex key.

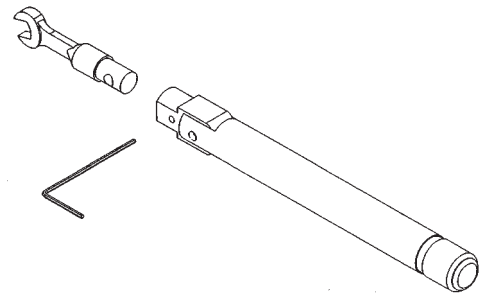

Applying Torque

1. Toward the end of the wrench is the “Load Point Line.” Grab handle at that “Load Point” end to apply torque. (If you grab the handle closer toward head, then you will apply more torque than what the wrench is set for. The wrench is a length dependent tool).
2. Tighten nut or bolt by applying a steady even pull. Wrench should be kept at 90 degrees to axis of bolt during tightening. When pre-set torque is reached, the wrench will ‘break.’ Stop pulling once 45° break angle is achieved.
2. Reset the wrench for the next application.
3. With its unique design, it’s impossible to over tighten beyond the preset load.

