



# Radiolink plus BLE



Hardened bushes to accept industry standard shackles

Internal Antennae

Std. AA Batteries 500hrs  
Easy no tools access

Environmental protection  
IP67 or NEMA6

High-quality hard anodised aerospace aluminium

Angular ends to reduce weight and snagging when rigged

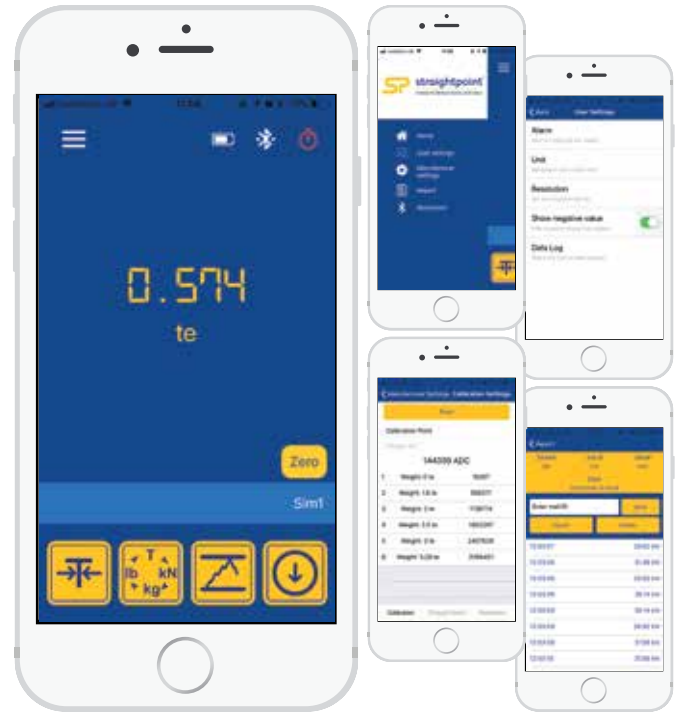

**Radiolink plus BLE is designed to be rigged with Crosby standard shackles. Straightpoint's DNV-GL type approved wireless tension load cell is capable of weighing and dynamic load monitoring capacities from 1t to 500t (all in stock).**

Constructed from high-quality aerospace grade aluminium, the RLP features an advanced internal design structure. This design provides the product with an unrivalled strength to weight ratio. The use of a separate internal sealed enclosure administers the load cell's electronic components with IP67 or NEMA6 environmental protection, even with the battery cover plate missing. All these features makes it an industry-leading dynamometer, suitable for use in the harshest of environments.

The versatile RLP BLE is able to provide an update rate of 3Hz, making it ideal for dynamic force measurement.

Decades of development into this product include many stand out features, such as SP's unique strain gauging method that helps compensate for wire rope torque when it is loaded.

## Features and benefits:

- Proprietary 4.2 Bluetooth
- Design validated by F.E.A.
- 2-year warranty
- DNV-GL Type Approval
- Complies with ASME B30.26
- Supplied with a free HHP App for iOS and Android
- Multiple weight unit measurement options (Te/Kg/lb/kN)
- Peak Hold button
- Zero and Gross monitoring options
- Audible alarm alert for high/low values
- User defined resolution setup
- Connects to up to 8 smart devices simultaneously
- Up to 100m or 328ft remote monitoring distance
- Measurement reporting
- Export measurement report

Accessories available for the handheld:

**Wall or Cab Mount Bracket**  
SP Crosby Part Nos. **SU3282 2789228**

**Rugged Rubber Boot**  
SP Crosby Part Nos. **SU4045 2789232**

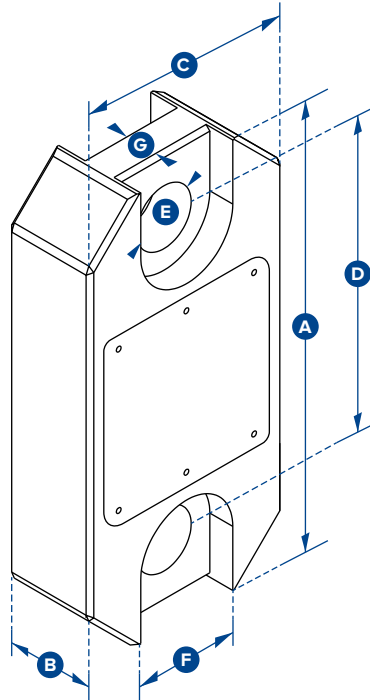

Part Numbers															
SP	CP1T-BLE	CP2T5-BLE	CP6T5-BLE	CP12T-BLE	CP25T-BLE	CP35T-BLE	CP55T-BLE	CP75T-BLE	CP100T-BLE	CP150T-BLE	CP200T-BLE	CP250T-BLE	CP300T-BLE	CP500T-BLE	
Crosby	2789005	2789009	2789014	2789003	2789008	2789011	2789013	2789015	2789002	2789004	2789006	2789007	2789010	2789012	
Capacity	1,000kg 2200lb	2.5te 5500lb	6.5te 14300lb	12te 26000lb	25te 55000lb	35te 77000lb	55te 120000lb	75te 165000lb	100te 220000lb	150te 330000lb	200te 440000lb	250te 550000lb	300te 660000lb	500te 1100000lb	
Resolution	0.5kg 1lb	0.001te 2lb	0.001te 2lb	0.002te 5lb	0.005te 10lb	0.005te 10lb	0.01te 20lb	0.01te 20lb	0.05te 100lb	0.05te 100lb	0.1te 200lb	0.1te 200lb	0.1te 200lb	0.1te 200lb	
Units	kg lb	te lb	te lb	te lb	te lb	te lb	te lb	te lb	te lb	te lb	te lb	te lb	te lb	te lb	
Weight	1.5kg 3.3lb	1.5kg 3.3lb	2.4kg 5.3lb	3.7kg 8.2lb	5kg 11lb	8.6kg 19lb	13kg 28.7lb	16kg 35.3lb	34kg 75lb	46kg 101.4lb	82kg 180.8lb	82kg 180.8lb	118kg 260lb	193kg 425.5lb	
Safety Factor	12:1	7:1	7:1	7:1	5:1	5:1	5:1	5:1	5:1	4:1	5:1	4:1	5:1	5:1	
Battery Type	Load cell 4 x AA														
Battery Life	500 hours														
Display Type	6 digit 25mm or 1" LCD														
Operating Temp	-10°C to +50°C or 14°F to 122°F														
Accuracy	±0.1% of full scale														
Frequency	Bluetooth 4.2														
System Range	100 metres or 328 feet														
Data Rate	3 Hz														
Protection	IP67 or NEMA6														
Dimension A	204 8.03"	204 8.03"	249 9.80"	305 12.01"	340 13.39"	393 15.47"	424 16.69"	470 18.50"	608 23.94"	670 26.38"	700 27.56"	700 27.56"	806 31.73"	930 36.61"	
Dimension B	43 1.69"	43 1.69"	43 1.69"	47 1.85"	60 2.36"	75 2.95"	75 2.95"	75 2.95"	99 3.90"	99 3.90"	144 5.67"	144 5.67"	150 5.91"	150 5.91"	
Dimension C	104 4.09"	104 4.09"	113 4.45"	113 4.45"	115 4.53"	126 4.96"	180 7.09"	202 7.95"	255 10.04"	303 11.93"	350 13.78"	350 13.78"	426 16.77"	570 22.44"	
Dimension D	146 5.75"	146 5.75"	165 6.50"	193 7.60"	215 8.46"	225 8.86"	230 9.06"	260 10.24"	320 12.60"	360 14.17"	350 13.78"	350 13.78"	350 13.78"	450 17.72"	
Dimension ØE	24.5 0.96"	24.5 0.96"	38 1.50"	47.5 1.87"	55 2.17"	60 2.36"	76 2.99"	76 2.99"	109 4.29"	109 4.29"	145 5.71"	145 5.71"	160 6.30"	200 7.87"	
Dimension F	48 1.89"	48 1.89"	66 2.60"	Not relevant in this capacity											
Dimension G	19 0.75"	19 0.75"	32 1.26"												
Crosby Shackle	G2130						G2140						G2160		
Loading Pin Ø	19 3/4"	19 3/4"	25 1"	35 1 3/8"	51 2"	57 2 1/4"	57 2 1/4"	70 2 3/4"	83 3 1/4"	95 3 3/4"	121 4 3/4"	127 5"	152 6"	180 7 1/8"	