



# wireless loadshackle



Available from stock in capacities 3.25t to 120t and available up to 1,550t, the WLS is manufactured from Crosby's industry leading 2130 Carbon and 2140 Alloy Bolt Type Anchor Shackles (3.25te – 120te) and the GN H10 Alloy Bolt Type Anchor Shackle (200te on up).

Straightpoint's Wireless Loadshackle provides the perfect solution to limited headroom applications. Each Wireless Loadshackle is proof tested, then equipped with a hard anodized aluminum electronics enclosure. Contained within this aluminum enclosure is a new internal chassis providing IP67/NEMA6 environmental protection even with the battery cover plate missing.

Featuring industry leading wireless technology and 2,300 foot range, the Wireless Loadshackle is supplied with an update rate of 3Hz and can be easily configured to run at industry leading speeds of up to 200Hz. Data is transmitted wirelessly utilizing the latest in IEEE 802.15.4 (2.4 GHz) technology providing safe, high integrity, error free transmission of both static weight and dynamic load to a wireless handheld controller or wireless Windows® PC data logging software package. Our wireless data logging software allows for simultaneous control, display and real time data logging of up to 100 Straightpoint telemetry load cells. Logged data is captured in a .csv file format and opens in MS Excel providing easy visual presentation, analysis of logged data, and simple test certificate generation.

Our Wireless Loadshackle utilizes easily sourced AA alkaline batteries and features advanced circuitry designed to protect the unit from damage associated with incorrectly installed batteries. This advanced circuitry extends battery life and the use of easily sourced alkaline batteries eliminates issues associated with rechargeable battery pack charging, failure and replacement. Our huge range of tooling allows us to calibrate in shackle for extra accuracy unlike many other load cell manufacturers. A full array of wireless accessories are also available including signal boosters, LED wireless scoreboards and base stations with analogue (4-20mA, 0-10v, 0-5v) or digital (RS232/485, Modbus RTU, and ASCII serial communications protocol) outputs. There is no better choice than Straightpoint's Wireless Loadshackle for limited headroom applications.

## Features and benefits:

- Proprietary 2.4 GHz wireless
- Error free data transmission
- Environmentally sealed
- Internal antennae
- Remote on/off
- Industry leading 2,300 foot wireless range
- Unrivaled resolution
- Unmatched battery life
- Low headroom
- Lightweight
- Each WLS is supplied with a load-centering bobbin
- Design validated by F.E.A.

# imperial specifications

# wireless loadshackle

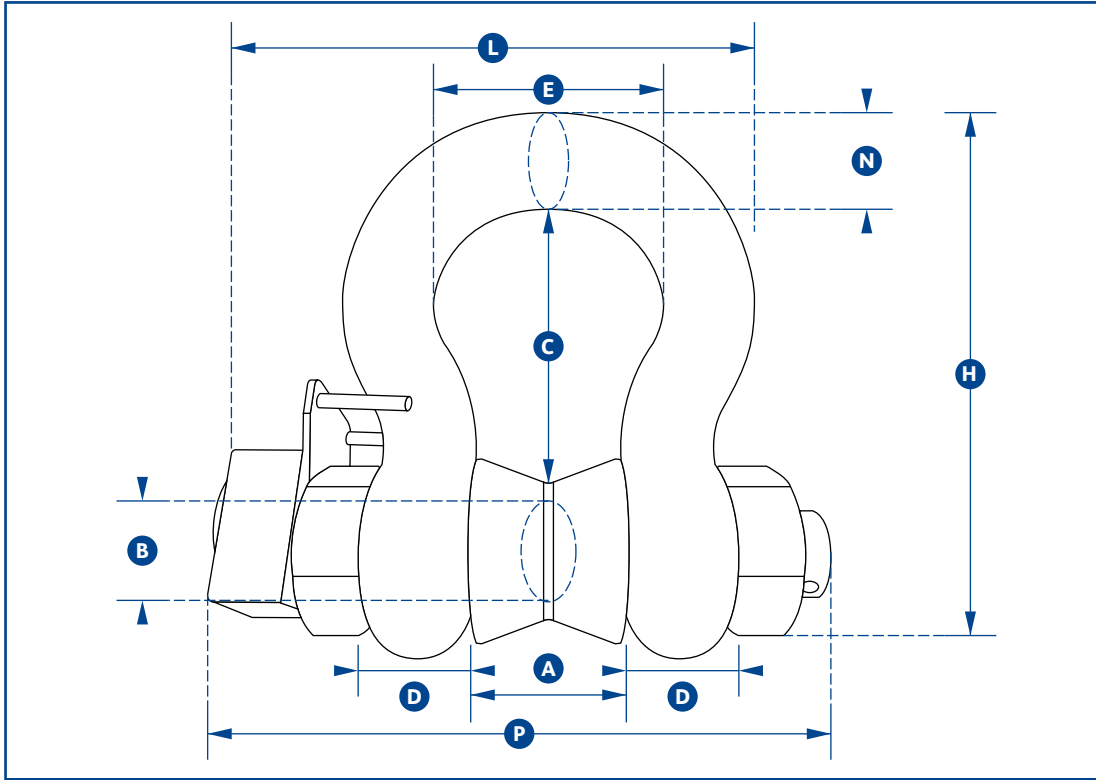

Part Number	WLS3.25TU	WLS6.5TU	WLS12TU	WLS25TU	WLS55TU	WLS85TU	WLS120TU	WLS200TU	WLS300TU	WLS400TU
Capacity	7150lb	14300lb	26400lb	55000lb	120000lb	185000lb	260000lb	440000lb	660000lb	880000lb
Resolution	10lb	10lb	20lb	50lb	100lb	100lb	200lb	200lb	1000lb	1000lb
Units	lb									
Weight	6.16lb	7lb	17.6lb	40lb	55lb	99lb	187lb	560lb	825lb	1354lb
Safety Factor	5:1 when used with load bobbin									
Battery Type	Load cell 4 x AA Alkaline									
Battery Life	Load cell 1200hrs continuous									
Operating Temp	-10°C to +50°C / 14°F to 122°F									
Accuracy	±1 % of applied load									
Frequency	2.4GHz									
System Range	700 meters / 2300 feet									
Data Rate	3 updates per second									
Protection	IP67 / NEMA 6									
Dimension A	1.06	1.44	2.03	2.87	3.25	4.13	5.00	7.09	8.07	9.06
Dimension B	0.75	1.00	1.38	2.01	2.24	2.76	3.25	4.92	5.91	6.89
Dimension C	2.38	3.31	4.69	7.01	7.76	10.51	12.99	13.15	15.67	17.32
Dimension D	0.63	0.88	1.25	1.75	2.01	2.62	2.99	4.72	5.12	6.50
Dimension E	1.69	2.28	3.25	5.00	6.46	7.24	7.87	11.42	12.01	12.80
Dimension H	4.17	5.83	8.27	12.32	13.70	17.83	21.50	31.89	37.40	43.31
Dimension L	5.20	6.22	7.72	11.06	12.05	14.49	16.06	22.83	24.21	27.76
Dimension N	0.69	0.97	1.38	2.24	2.40	3.11	3.62	4.72	5.12	6.50
Dimension P	5.83	7.09	8.58	11.54	12.48	15.51	17.36	22.44	24.41	28.15

Larger capacities up to 1000te (price on application).

## CHECK•LINE®—PRECISION QUALITY CONTROL INSTRUMENTS

**Electromatic Equipment Co., Inc.**  
600 Oakland Ave.  
Cedarhurst, NY 11516 —USA

**Tel:** (800) 645-4330 (USA & Canada)  
**Tel:** (516) 295-4300  
**Fax:** (516) 295-4399

**Email:** info@checkline.com  
**Website:** www.checkline.com

**For additional information or to place an order CALL TOLL FREE 1-800-645-4330**

Check•Line is a registered trademark of Electromatic Equipment Company Inc.