

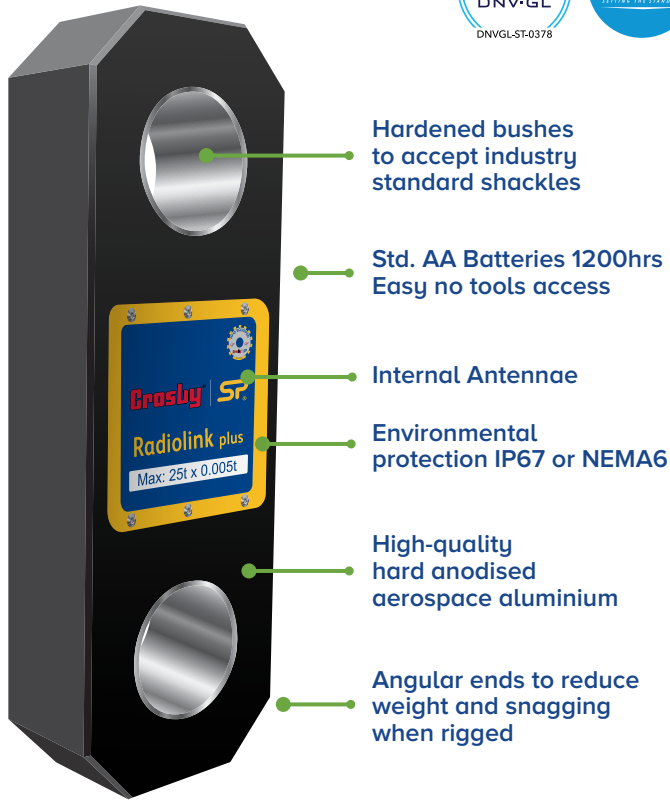

Radiolink plus



Hardened bushes to accept industry standard shackles

Std. AA Batteries 1200hrs Easy no tools access

Internal Antennae

Environmental protection IP67 or NEMA6

High-quality hard anodised aerospace aluminium

Angular ends to reduce weight and snagging when rigged

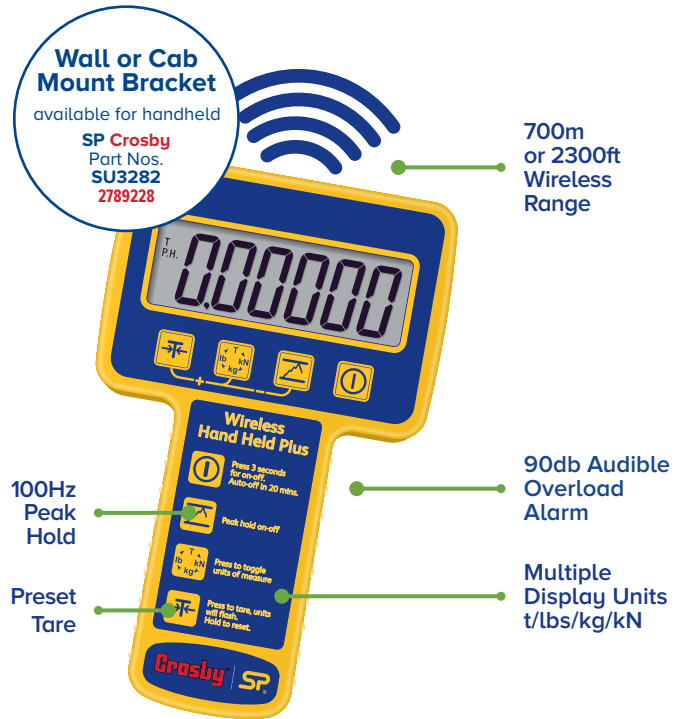

Wall or Cab Mount Bracket

available for handheld

SP Crosby
Part Nos.
SU3282
2789228

700m or 2300ft Wireless Range

100Hz Peak Hold

Preset Tare

90db Audible Overload Alarm

Multiple Display Units t/lbs/kg/kN

Radiolink plus is designed to be rigged with Crosby standard shackles. Straightpoint's DNV-GL type approved wireless tension load cell is capable of weighing and dynamic load monitoring capacities from 1t to 500t (all in stock). An ATEX and IECEx version is also available for hazardous areas, zones 0, 1 & 2.

Two versions of the RLP are available:

- Long range 2.4GHz version providing industry leading wireless range of 700m or 2300ft to SP's SW-HHP handheld or software options.
- Bluetooth output and can be connected to any smart phone running our free HHP app on iOS or Android, at ranges up to 100m or 328ft.

Constructed from high-quality aerospace grade aluminium, the RLP features an advanced internal design structure. This design provides the product with an unrivalled strength to weight ratio. The use of a separate internal sealed enclosure administers the load cell's electronic components with IP67 or NEMA6 environmental protection, even with the battery cover plate missing. All these features makes it an industry-leading dynamometer, suitable for use in the harshest of environments.

The versatile RLP is able to provide an update rate of 3Hz and can be easily configured to run at industry-leading speeds of up to 200Hz, making it ideal for dynamic force measurement.

Decades of development into this product include many stand out features, such as SP's unique strain gauging method that helps compensate for wire rope torque when it is loaded. The Radiolink plus tension load cell can also be used in combination with Straightpoint SW-MWLC high speed wireless data logging software, allowing for simultaneous control, display and real-time data logging of up to 100 Straightpoint wireless load cells.

A full array of wireless accessories are also available. They include signal boosters, LED wireless scoreboards and base stations with analogue (4-20mA, 0-10v, 0-5v) or digital (RS232/485, Modbus RTU, and ASCII) outputs.

Features and benefits:

- Proprietary 2.4 GHz Wireless
- Remote On-Off from handheld display or software
- ATEX Zones 0, 1 & 2 available
- Design validated by F.E.A.
- 2-year warranty
- DNV-GL Type Approval
- Complies with ASME B30.26
- Bluetooth option is available and is supplied with a free HHP App for iOS and Android

Also available with hazardous area approval. Zones 0, 1 & 2



ATEX / IECEX

Ex ia II C T4 Ga

Certification numbers:

RLP ATEX

IECEX SIR 15.0071X / Sira 15ATEX2195X

SW-HHP ATEX

IECEX SIR 15.0072X / Sira 15ATEX2196X

Add 'ATEX' to the part number when ordering ATEX/IECEX products. For example: RLP6T5-ATEX

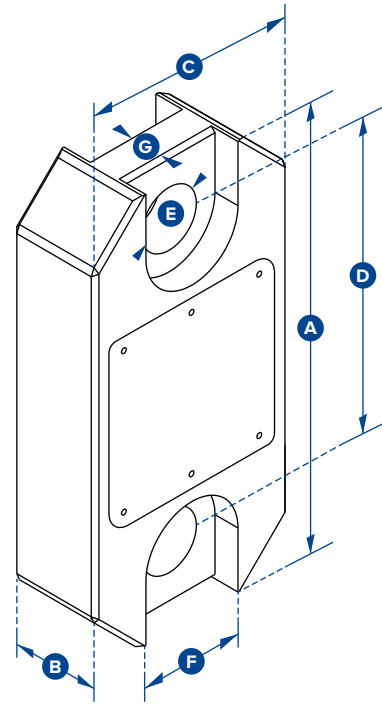

Part Numbers														
SP	RLP1T	RLP2T5	RLP6T5	RLP12T	RLP25T	RLP35T	RLP55T	RLP75T	RLP100T	RLP150T	RLP200T	RLP250T	RLP300T	RLP500T
Crosby	2789084	2789089	2789094	2789082	2789083	2789091	2789093	2789095	2789081	2789083	2789085	2789087	2789090	2789092
Capacity	1,000kg 2200lb	2.5te 5500lb	6.5te 14300lb	12te 26000lb	25te 55000lb	35te 77000lb	55te 120000lb	75te 165000lb	100te 220000lb	150te 330000lb	200te 440000lb	250te 550000lb	300te 660000lb	500te 1100000lb
Resolution	0.5kg 1lb	0.001te 2lb	0.001te 2lb	0.002te 5lb	0.005te 10lb	0.005te 10lb	0.01te 20lb	0.01te 20lb	0.05te 100lb	0.05te 100lb	0.1te 200lb	0.1te 200lb	0.1te 200lb	0.1te 200lb
Units	kg lb	te lb	te lb	te lb	te lb	te lb	te lb	te lb	te lb	te lb	te lb	te lb	te lb	te lb
Weight	1.5kg 3.3lb	1.5kg 3.3lb	2.4kg 5.3lb	3.7kg 8.2lb	5kg 11lb	8.6kg 19lb	13kg 28.7lb	16kg 35.3lb	34kg 75lb	46kg 101.4lb	82kg 180.8lb	82kg 180.8lb	118kg 260lb	193kg 425.5lb
Safety Factor	12:1	7:1	7:1	7:1	5:1	5:1	5:1	5:1	5:1	4:1	5:1	4:1	5:1	5:1
Battery Type	Handheld 2 x AA / Load cell 4 x AA													
Battery Life	Handheld 60 hours/Load cell 1200 hours continuous (Load cell 500 hours if Bluetooth)													
Display Type	6 digit 25mm or 1" LCD													
Operating Temp	-10°C to +50°C or 14°F to 122°F													
Accuracy	±0.1% of full scale													
Frequency	2.4 GHz													
System Range	700 metres or 2300 feet (100 metres or 328 feet if Bluetooth)													
Data Rate	3 Hz - up to 200 Hz can be ordered for dynamic load monitoring applications													
Protection	IP67 or NEMA6													
Dimension A	204 8.03"	204 8.03"	249 9.80"	305 12.01"	340 13.39"	393 15.47"	424 16.69"	470 18.50"	608 23.94"	670 26.38"	700 27.56"	700 27.56"	806 31.73"	930 36.61"
Dimension B	43 1.69"	43 1.69"	43 1.69"	47 1.85"	60 2.36"	75 2.95"	75 2.95"	75 2.95"	99 3.90"	99 3.90"	144 5.67"	144 5.67"	150 5.91"	150 5.91"
Dimension C	104 4.09"	104 4.09"	113 4.45"	113 4.45"	115 4.53"	126 4.96"	180 7.09"	202 7.95"	255 10.04"	303 11.93"	350 13.78"	350 13.78"	426 16.77"	570 22.44"
Dimension D	146 5.75"	146 5.75"	165 6.50"	193 7.60"	215 8.46"	225 8.86"	230 9.06"	260 10.24"	320 12.60"	360 14.17"	350 13.78"	350 13.78"	350 13.78"	450 17.72"
Dimension ØE	24.5 0.96"	24.5 0.96"	38 1.50"	47.5 1.87"	55 2.17"	60 2.36"	76 2.99"	76 2.99"	109 4.29"	109 4.29"	145 5.71"	145 5.71"	160 6.30"	200 7.87"
Dimension F	48 1.89"	48 1.89"	66 2.60"	Not relevant in this capacity										
Dimension G	19 0.75"	19 0.75"	32 1.26"											
Crosby Shackle	G2130													
Loading Pin Ø	19 3/4"	19 3/4"	25 1"	35 1 3/8"	51 2"	57 2 1/4"	57 2 1/4"	70 2 3/4"	83 3 1/4"	95 3 3/4"	121 4 3/4"	127 5"	152 6"	180 7 1/8"