

# FI-521 Indicator



## Operation & Service Manual

**V02.03**

**Contents Subject to Change without Notice**

# CONTENT

1 Specification.....	4
2. Faceplate.....	7
3. Summary of Key function .....	8
4. Operation Menu Structure.....	9
5. Normal Force Measure mode .....	19
6. Calibration .....	21
7. Force Fine-tune .....	22
8. View ADC output Code & calibrate input signal in mV/V .....	22
9. View and Calibrate Power Voltage .....	23
10. View and Set Time.....	23
11. View and Set Date .....	24
12. View Firmware Version.....	24
13. View COM2's Type .....	24
14. View the Times of Load Cell was Abused .....	24
15. View Zero Offset.....	24
16. Display Test .....	24
17. Keyboard and Buzzer Test.....	25
18. Input Test .....	25
19. Output Test .....	25
20. Serial Port1/2 (COM1/2) Receiving Test.....	25
21. Serial Port1/2(COM1/2) Transmitting Test.....	25
22. Remote Input Function Selection .....	26
23. Output Setting .....	26
24. Analog Voltage Output Setup .....	26
25. Details about Serial Communication .....	27
26. Sockets and Jumpers.....	32
27 Meaning of Some Symbols and Troubleshooting.....	38
28. Display Character .....	40
29. Packing List.....	41
30. Version History.....	41



**FI-521 Series Indicator Operation Manual**

Thank you for purchasing the FI-521 series indicator. Please read all operating instructions carefully before use and keep the following points in mind:

- \* Avoid lengthy exposure to extreme heat or cold, your indicator works best when operated at normal room temperature. Always allow the indicator to acclimate to a normal room temperature before use
- \* Allow sufficient warm up time. Turn the indicator on and wait for a few minutes if possible, to give the internal components a chance to stabilize before measurement.
- \* These electronic indicators are precision instruments. Do not operate near an in-use cell phone, radio, computer or other electronic device. These devices emit RF and can cause unstable indicator readings. If your indicator ever performs poorly, try moving the indicator to a different room or location.
- \* Avoid using in condition of heavy vibration and airflow.
- \* Force measurement Readings are usually immediate Readings. The output of the Load cell and indicator may drift over prolonged periods.

(2012)

**Specification**

**1.1 Models of FI-521 series:**

MODEL	Description
FI-521E	LED Version, no battery
FI-521EB	LED Version, 6V lead-acid rechargeable battery is installed

**1.2 Housing and Outline Dimension:**

1.2.1 IP65 wash-down stainless steel housing with rotary bracket

1.2.2 Outline Dimension:

With bracket: 10.3" x 8.5" x 3.8" (262mm x 215mm x 96mm)

Without bracket: 8.9" x 6.3" x 3.8" (225mm x 160mm x 96mm)

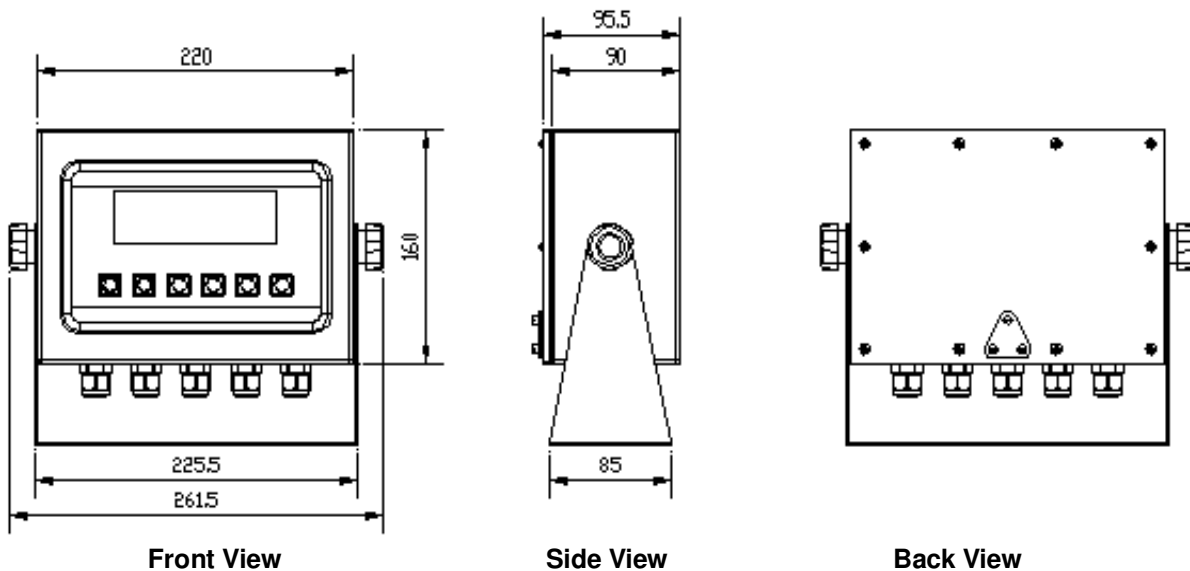

**1.3 Power Supply:**

- 1.3.1 12 Vdc / min.500mA output AC adapter with central positive
- 1.3.2 Optional 6V2.8-4AH lead-acid rechargeable battery
- 1.3.3 Working Current:
  - (1)  $\leq 135\text{mA}$ , adaptor used, no load-cell, no battery, LED.BRT is set to 2
  - (2)  $\leq 100\text{mA}$ , battery used, no load-cell, no adaptor, LED.BRT is set to 2
- 1.3.4 Battery charging Circuit: built-in

**1.4 Display:**

- 1.4.1 7-digits, 7-segment, 0.7"(17mm) ultra brightness LEDs with 14 annunciators

**1.5 Keypad:** 6 push buttons of SELECT, CELL, PRINT, UNIT, ZERO, ON/OFF**1.6 Environment:**

- 1.6.1 Working temperature:  $-10^{\circ}\text{C}$  to  $40^{\circ}\text{C}$
- 1.6.2 Storage temperature:  $-20^{\circ}\text{C}$  to  $70^{\circ}\text{C}$
- 1.6.3 Humidity: 10 to 90% RH without condensation
- 1.6.5 Protection: IP65

**1.7 Load cell Excitation:**

- 1.7.1 Voltage: 5Vdc
- 1.7.2 Max. Current: 120mA (can power 8-350 ohm bridge)
- 1.7.3 Signal connection: 4 or 6 lead with sense leads
- 1.7.4 Max Sensitivity:  $-3\text{mV/V}$  to  $+3\text{mV/V}$

**1.8 Communication:**

- 1.8.1 Serial port1: Full-duplex RS232
- 1.8.2 Serial port2: Full-duplex RS232 or half-duplex RS485
- 1.8.3 Baud Rate: Selectable: 1200-2400-4800-9600-19200-22800/38400-57600 bps
- 1.8.4 Data Output Format: 8N1, 7O1, 7E1
- 1.8.5 Protocol: selectable

**1.9 Analog Circuit characters:**

- 1.9.1 24-bit A/D converter
- 1.9.2 Conversion Speed: 80Hz
- 1.9.3 Input range:  $-15\text{mV}$  to  $+15\text{mV}$
- 1.9.4 Output code: 1mV input between S+ and S- of load cell connector will output about 100,000 raw Counts.
- 1.9.5 With Hardware low pass filter and 2 programmable digital low pass filters

**1.10 Capacity and Division:** Programmable

- 1.10.1 Max display range: -999,999 to 999,999
- 1.10.2 Division number range for primary unit: 100-100,000  
Division number range for second unit: 100-125,000  
Division number range for Newton unit: 100-125,000
- 1.10.3 Recommended Display Sensitivity:  $>0.5\mu\text{V/}$  display division

**1.11 Accuracy:**  $\leq 0.01\%$ **1.12 Calibration Method:**

- 1.12.1 Software calibration with long-term storage in EEPROM
- 1.12.2 Provides smooth curve fit through linearization points.
- 1.12.3 Calibration can be done under kgf or lbf force unit with 10% -100%FS standard force

**1.13 Real Clock:** built-in nonvolatile real time & date

**1.14 Remote Digital Input:**

1.14.1 There're four external inputs.

1.14.2 Function: each input can be defined to HOLD, ZERO, TARE, PRNT, UNIT, OFF or NONE

**1.15 Digital Output (Set point Output):**

1.15.1 There're two configurable outputs

1.15.2 Each digital output combined with a digital comparator: if current force is over or less than the set force point, the corresponding output will change its output electronic lstate according to the pre-configuration.

**1.16 Analog Voltage Output:**

1.16.1 The output voltage is 0-2.5V, the output current should be limited 5mA by external circuit.

1.16.2 The accuracy of this analog voltage is about 0.01% after calibration

**1.17 Other Main Function:**

1.17.1 Programmable Zero Range

1.17.2 Programmable automatic zero point tracking

1.17.3 Programmable motion detection window

1.17.4 Programmable auto-power off time, adjustable LED brightness

1.17.5 Available Measure Unit: kgf, lbf, Newton

1.17.6 Battery voltage display and charge indicate

1.17.7 Programmable serial output content

1.17.8 Two set points output with two data comparison points

## 2. Faceplate

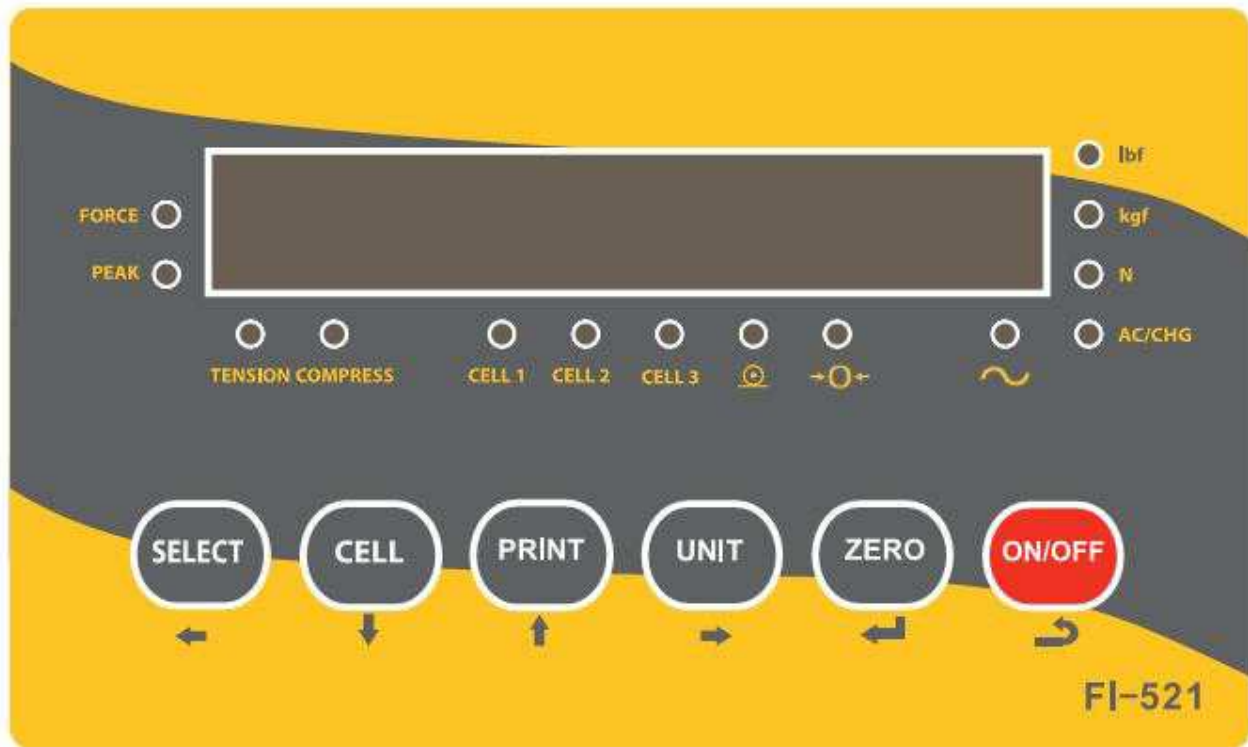

### 2.1 Meaning of symbol on faceplate:

2.1.1 **FORCE**-----Illuminates when indicator is in force display mode.

2.1.2 **PEAK**-----Illuminates when indicator is in peak display mode. When it's flashing, the displayed number is live force, when it's steady, the number is peak force.

2.1.3 **lbf,kgf,N**-----Illuminates the active unit of measure .

2.1.4  -----**Data Send**: Illuminates when the indicator is transmitting data.

2.1.5  -----**Zero**: Illuminates when the indicator is within the configured center of zero.

2.1.6  -----**Motion**: Illuminates when the indicator detects motion (out of configured motion window).

2.1.7 **TENSION, COMPRESS**-----Indicates the type of force being measured.

2.1.8 **CELL1, CELL2, CELL3**-----Show which Load Cell that is being used

2.3.9 **AC/CHG** ---Red when battery is being charged, Green when it's full or not installed

**3. Summary of Key function**

Key	Condition	Function
<b>SELECT</b> ←	Weighing: press less than 3 seconds	To select displayed content type: Force↔Peak
	Weighing: press 3 seconds or more	To enter CONFIG mode
	Input data mode or Menu selection mode	Return to last sub-menu
<b>CELL</b> ↓	Weighing: press less than 3 seconds	To select Cell1→Cell2→Cell3→Cell1
	Input data mode	The digit on flashed position subtract 1
	Menu selection mode	To Next item of current menu
<b>PRINT</b> ↑	Weighing: press down	Output data to serial communication port
	Input data mode	the digit on flashed position add 1
	Menu selection mode	To last item of current menu
	Display ADC code mode	Select displaying ADC code from no-filter, filter1, filter2
<b>UINT</b> →	Weighing mode, press less than 3 seconds	Change weighing units: lbf->kgf->N->lbf
	Display date or time mode, press 3 seconds or more	To set current date or time
	Display voltage mode, press 3 seconds or more	To calibrate input voltage value
	Display ADC code, press less than 3 second	Select displaying ADC code or displaying input signal in mV/V
	Display ADC code, press 3 seconds or more	To calibrate input signal in mV/V
	Input data mode	Rotate the flashed position from left to right
<b>ZERO</b> ←	Weighing: press less than 3 seconds	Zero function
	input data mode or Menu selection mode	To confirm input data or current item selection, and go to next item of current menu, or next operation
	Display ADC code	Set or clear reference "Zero" code
<b>ON/OFF</b> ↵	Power off mode	Power on
	Weighing: press 3 seconds or more	Power off
	Input data mode	ignore modification
	Menu selection mode	Prepare to exit from current working mode

**Note:**

Normally, the second function of one key need pressing it down more than 3 seconds.



**4. Operation Menu Structure**

**4.1 Main menu:**

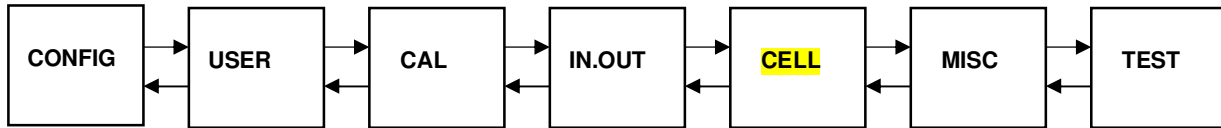

**NOTE:**

- (1) Each LOAD CELL has its own CONFIG, CAL, IN.OUT parameters, so, before you enter this main menu select, which load cell will be configured should be with the CELL key!
- (2) The parameters of USER, MISC, and TEST are the same for all load cells
- (3) When “Lo.VoL” or “Lo.BAT” is displayed (the voltage to PCB is low), CONFIG, USER, CAL, IN.OUT menu can not be entered and edited.

**4.2 CONFIG Submenu:**

CONFIG				
SubMenu1	SubMenu2	Option	Default	Remark
CFG.ON CFG.OFF				seal switch is on or off
RESET		NO	NO	reset configure parameters to default setting
		YES		
CELL.TY		Tension	Tension	Select the connected load cell is used for tension or compression force
		Compres		
DSP.POL		Pos	Pos	When CELL.TY= Compres and calibrated in negative direction, if DSP.POL=Pos, then reading will be displayed in Positive, if DSP.POL=Neg, then the reading will be displayed in Negative
		Neg		
PRIM.N		100 – 100,000	10,000	the division number under primary unit
PRIM.D		0.0001, 0.0002, 0.0005, 0.001, 0.002, 0.005, 0.01, 0.02, 0.05, 0.1, 0.2, 0.5, 1, 2, 5, 10, 20, 50	1	The division value under primary unit; the division value under second unit is automatically determined by indicator according to the division value under primary unit.

PRIM.U		KGF	LBF	Select the primary unit from kg or lb, the second unit is the lb if kg selected as primary unit or kg if lb selected as primary unit; the calibration standard weight must be in primary unit!	
		LBF			
SECOND.N		100-125,000	10,000	the division number under second unit ,the max is 1.25*(PRIM.N),	
NEWTON.N		100 – 125,000	10,000	the division number under the NEWTON unit ,the max is 1.25*(PRIM.N),	
UNITS		0-6	6	units that can use UNIT key to select: 0=kgf, 1=lb, 2=N(Newton), 3= kgf,lb, 4=kgf,N, 5=lb,N, 6=kgf,lb,N refer to section5.12 for some limitation	
MOTION		1-255	4	Check motion window: 1-255=±0.25d *(1-255)	
OVER.LD		0-100	0	over load display limitation: 0=FS+9d, 1-100=101%FS to 200%FS	
ABSUE		0-255	20	FS+(0%FS to 255%FS), If the force has exceed this level, it's considered to be abusive to the load cell	
ZRO.PNT	P.IZSM	0-100	10	Initial zero(power on zero) point range: 0=no limitation, 1-100= (calibration zero point) + 1%FS to (calibration zero point) +100%FS	
	N.IZSM	0-100	10	Initial zero(power on zero) point range: 0=no limitation, 1-100= (calibration zero point) – 1%FS to (calibration zero point) -100%FS	
	IN.IZSM	FORCE	FORCE		Which force will works as initial zero point when force is <u>in</u> IZSM range: FORCE= current force ; CAL.ZRO= calibration zero; LAST.ZRO=switch-off zero force
		CAL.ZRO			
		LAST.ZRO			
	OV.IZSM	DSP.OVR	DSP.OVR		Choose which force will works as initial zero point when force is <u>over</u> IZSM range: DSP.OVR=display initial zero point is over; FORCE= current force; CAL.ZRO= calibration zero; LAST.ZRO=switch-off zero force
		FORCE			
		CAL.ZRO			
		LAST.ZRO			
SAZSM	0-100	2	Zero key range: 0=no limitation, 1-100= (initial zero point) ±1%FS to (initial zero point) ±100%FS		
AZSM	0-255	2	Zero tracking window: 0=0d, no tracking; 1-255=±0.25d*(1-255)		

FILTER	FLT1.TH	0-255	160	Enter digital filter1 threshold: 0=no filter1; 1-254=filter1 be used only when vibration in $\pm 0.5d^*(1-254)$ ; 255= filter1 be always used
	FLT1.ST	1-64	32	Digital filter1 intensity: 1-64 ADC's data will be averaged
	FLT2.TH	0-255	80	Enter digital filter2 threshold: 0=no filter2; 1-254=filter2 be used only when vibration in $\pm 0.5d^*(1-254)$ ; 255= filter2 be always used
	FLT2.ST	0-255	192	Digital filter2 intensity: 0-255=weak to strong
FUNC	F.ADJ	YES	NO	Enable or disable fine-adjust force number in normal force measure mode
		NO		
PEAK	Threshd	5-65535	10	5-65535d, When reverse varying(Threshold) of force is over this value, one peak is occurred and will be captured

**4.3 USER Submenu:**

<b>USER</b>				
Sub-Menu1	SubMenu2	Option	Default	Remark
RESET	NO	NO		reset user parameters to default setting
	YES			
COM1	BAUD.RT	1200	9600	selection of com1's baud rate
		2400		
		9600		
		19200		
		38400		
		57600		
	BYT.FMT	8N1	8N1	selection of com2's byte format: (1) 8N1=8 data bits, No parity check bit, 1 stop bit; (2) 7O1=7 data bits, 1 Odd parity check bit, 1 stop bit; (3) 7E1=7 data bits, 1 Even parity check bit, 1 stop bit
		7O1		
		7E1		
	OUT.MOD	NONE	PRT.CMD	Selection com1 output mode: (1)NONE=COM1 disabled (2)CONT=continuously output; (3)PRINT=output after PRINT key pressed; (4)CMD=output after a request command is received; (5)PRT.CMD= output after PRINT key pressed or request command received; (6)STABLE=output after indicator is stable;  Note: use PRINT or CMD to output data, the indicator must be stable.
		CONT		
		PRINT		
		CMD		
		PRT.CMD		
		STABLE		
	LAYOUT	MULTPL	MULTPL	COM1 output content and format set: (1)MULTPL= the following selected item in <b>OUT1</b> will be output use defined format; (2)SINGLE= only displayed content and current status will be output, it's compatible with NCI-SCP01 (3)EDX=only displayed content and current status will be output, it's compatible with EDX
		SINGLE		
		EDX		
OUT1	TITLE	YES	NO	Yes/No=enable/disable output prompt of every output line
		NO		
	IND.ID	YES	NO	Yes/No=enable/disable output indicator's ID number, Prompt is "IND. ID"
		NO		
	CELL.No	YES	NO	Yes/No=enable/disable output load cell's ID number, Prompt is "CELL No."
		NO		
	CELL.TYP	YES	NO	Yes/No=enable/disable output load cell's type, Prompt is "CELL TYPE"
		NO		

MEAS.TY	YES	NO	Yes/No=enable/disable output load cell's measure type, Prompt is "MEAS.TYPE" (Peak or Force)	
	NO			
FORCE	YES	YES	Yes/No=enable/disable output gross force. Prompt is "FORCE"	
	NO			
PEK.VLY	YES	NO	YES/NO=enable/disable output current captured peak value and valley value; prompt is "PEAK" and "VALLEY"	
	NO			
MAX.MIN	YES	NO	YES/NO=enable/disable output max peak and valley value, prompt is "Max."/ "Min."	
	NO			
DATE	YES	NO	Yes/No=enable/disable output date. Prompt is "DATE"	
	NO			
TIME	YES	NO	Yes/No=enable/disable output time. Prompt is "TIME"	
	NO			
AD.CODE	YES	NO	Yes/No=enable/disable output ADC's code. Prompt is "A/D CODE"	
	NO			
IN. mV/V	YES	NO	Yes/No=enable/disable output input signal in mV/V unit, Prompt is "INPUT"	
	NO			
BAT.VOL	NO	NO	Yes/No=enable/disable output voltage of battery. Prompt is "VOLTAGE"	
	NO			
STATUS	YES	NO	Yes/No=enable/disable output indicator's status. Prompt is "STATUS"	
	NO			
B.LINE	NONE, LINE1 -9	LINE1	How many blank lines after strings output: None,LINE1-9=there're 0 - 9 blank lines after strings	
COM2	BAUD.RT	1200	9600	selection of com2's baud rate
		2400		
		9600		
		19200		
		22800		
		57600		
	BYT.FMT	8N1	8N1	selection of com2's byte format: 1)8N1=8 data bits, no parity check bit, 1 stop bit; 2)7O1=7 data bits, 1 odd parity check bit, 1 stop bit; 3)7E1=7 data bits, 1 even parity check bit, 1 stop bit
7O1				
7E1				
OUT.MOD	NONE	NONE	Selection com2 output mode: (1)NONE=COM2 disabled; (2)CONT=continuously output; (3)PRINT=output after PRINT key pressed;	
	CONT			

		PRINT		(4)CMD=output after a request command is received; (5)PRT.CMD= output after PRINT key pressed or request command received; STABLE=output after indicator is stable; Note: use PRINT or CMD to output data, the indicator must be stable.
		CMD		
		PRT.CMD		
		STABLE		
	LAYOUT	MULTPL	MULTPL	COM2 output content and format set: (1)MULTPL= the following selected item in <b>OUT2</b> will be output use defined format; (2)SINGLE= only displayed content and current status will be output, it's compatible with NCI-SCP01 (3)EDX=only displayed content and current status will be output, it's compatible with EDX
		SINGLE		
	EDX			
LC.ADDR	00-99	01	Local address for COM2	
EN.ADDR	NO	NO	Yes/No=enable/disable using com2 local address in output or input strings	
	YES			
OUT2	TITLE	YES	NO	Yes/No=enable/disable output prompt of every output line
		NO		
	IND.ID	YES	NO	Yes/No=enable/disable output indicator's ID number, Prompt is "IND. ID"
		NO		
	CELL. No	YES	NO	Yes/No=enable/disable output load cell's ID number, Prompt is "CELL No."
		NO		
	CELL.TYP	YES	NO	Yes/No=enable/disable output load cell's type, Prompt is "CELL TYPE"
		NO		
	MEAS.TY	YES	NO	Yes/No=enable/disable output load cell's measure type, Prompt is "MEAS.TYPE" (Peak or Force)
		NO		
	FORCE	YES	YES	Yes/No=enable/disable output gross force. Prompt is "FORCE"
		NO		
	PEK-VLY	YES	NO	YES/NO=enable/disable output current captured peak and valley value; prompt is "PEAK" and "VALLEY"
		NO		
	MAX.MIN	YES	NO	YES/NO=enable/disable output max peak and valley value, prompt is "Max." and "Min."
		NO		
	DATE	YES	NO	Yes/No=enable/disable output date. Prompt is "DATE"
		NO		
TIME	YES	NO	Yes/No=enable/disable output time. Prompt is "TIME"	
	NO			
AD.CODE	YES	NO	Yes/No=enable/disable output ADC's code. Prompt is "A/D CODE"	
	NO			

	IN. mV/V	YES	NO	Yes/No=enable/disable output input signal in mV/V unit, Prompt is "INPUT"
		NO		
	BAT.VOL	YES	NO	Yes/No=enable/disable output voltage of battery. Prompt is "VOLTAGE"
		NO		
STATUS	YES	NO	Yes/No=enable/disable output indicator's status. Prompt is "STATUS"	
	NO			
	B.LINE	NONE, LINE1 – LINE9	LINE1	How many blank lines after strings output: NONE,LINE1 – LINE9=there're none,1 – 9 blank lines after strings
BEEP	KEY	YES	YES	Yes/No=enable/disable beep after a key pressed down
		NO		
PEAK	Display	MAX	MAX	Select what is displayed In peak display mode: MAX=Max. Force value; MIN=Min. Force value; PEAK=current captured peak value; VALLEY=current captured valley value;
		MIN		
		PEAK		
		VALLEY		
OTHER	NLD.RNG	1-255	10	1-255=the range of force is $\pm 1-255d$ ; when current force is less than this value, the load cell can be regarded as no load on it. It must be bigger than (CONFIG.MOTION).
	CMD.SRC	NONE	COM1	Source of the executed command selection: NONE=no any command will be executed; COM1= command from COM1 will be executed; COM2= command from COM2 will be executed; COM1-2= command from COM1 or COM2 will be executed;
		COM1		
		COM2		
		COM1-2		
	A.OFF.T	0-255	0	Auto off time: 0=not auto power off; 1-255=auto power off after 1-255 minutes, in this period, it should be no operation or no weight changing
	A.OFF.MD	OFF	OFF	Auto off mode: (1)OFF=turn off instrument; (2)DSP.TIM= display time; (3)DSP.DAT=display date; (4)AC.TIME=turn off when only battery is used, display time when AC adaptor is used; (5)AC.DATE=turn off when only battery is used, display date when AC adaptor is used;
		DSP.TIM		
DSP.DAT				
AC.TIME				
AC.DATE				
LED.BRT	BRT1-2-3-4-5	BRT4	LED brightness level set: BRT1-BRT2-BRT3-BRT4-BRT5=low – middle – high; only available on LED version	
IND.ID	000000 – 999999	123456	Indicator's ID number: 000000-999999	

**4.4 CAL Submenu:**

<b>CAL</b>				
SUBMENU1	SUBMENU2	OPTION	REMARK	
CAL.ON			seal switch is on	
CAL.OFF			seal switch is off	
ZERO			only do zero point calibration, then go to CAL.END to end	
LINE	CAL.P0		Line calibration point0: do zero point calibration, this point can't be omitted.	
	CAL.P1		Line calibration point1: do first weight point calibration, this point can't be omitted and standard weight must be over 10%FS.	
	END.Y	YES		End calibration? YES=go to CAL.END to end; NO=go to do next point calibration
		NO		
	CAL.P2		Line calibration point2: do second weight point calibration, standard weight must be over 10%FS and be larger than it in CAL.P1, this point can be omitted.	
	END.Y	YES		End calibration? YES=go to CAL.END to end; NO=go to do next point calibration
		NO		
	CAL.P3		Line calibration point3: do third weight point calibration, standard weight must be over 10%FS and be larger than it in CAL.P2, this point can be omitted.	
	END.Y	YES		End calibration? YES=go to CAL.END to end; NO=go to do next point calibration
		NO		
	CAL.P4		Line calibration point4: do forth weight point calibration, standard weight must be over 10%FS and be larger than it in CAL.P3, this point can be omitted.	
	END.Y	YES		End calibration? YES=go to CAL.END to end; NO=go to do next point calibration
		NO		
	CAL.P5		Line calibration point5: do fifth weight point calibration, standard weight must be over 10%FS and be larger than it in CAL.P4, this point can be omitted.	
INPUT			Input or view calibration parameters value that is got before	
CAL.END			calibration end and restart	

**NOTE:**

The details can be referred in section “**6.CALIBRATION**”



**4.5 MISC Submenu:**

<b>MISC</b>	
SUBMENU1	REMARK
CODE	display ADC's code, this code can be after no-filter, filter1 or filter2; or display input signal in mV/V; details refer to section8
VOL	display voltage; calibrate voltage; set full charged voltage and low battery voltage; details refer to section9
DATE	display date and set date; details refer to section11
TIME	display time and set time; details refer to section10
VER	display firmware version; details refer to section12
COM2.TY	Display type of COM2; details refer to section13
ABUS.CNT	View times of occurred abuse on selected cell; details refer to section14
ZERO.OFS	ZERO OFFSET: Current zero – Calibration zero; details refer to section15

**4.6 TEST Submenu:**

<b>TEST</b>	
SUBMENU1	REMARK
DISP.st	test LCD or LED; details refer to section17
COM1.rd	test COM1 receiving; details refer to section20
COM1.td	test COM1 transmitting; details refer to section21
COM2.rd	test COM2 receiving; details refer to section20
COM2.td	test COM2 transmitting; details refer to section21
KEY.tst	test keys and buzzer; details refer to section17
INPUT	To view the level of input lines; details refer to section18
OUTPUT	To set and check output level of output lines ; details refer to section19

**4.7 IN.OUT Submenu:**

IN.OUT			
SUB-MENU1	SUB-MENU2	SUB-MENU3	REMARK
INPUT	Inx. Yyyy		Select function(yyy) of each remote input(x) X=1-4; yyyy=SELE(select)/ CELL(cell)/ PRNT(print)/ UNIT(unit)/ ZERO(zero)/ OFF/ NONE(none); normally, one remote input is low (0), that means one external switch is closed
OUTPUT	MODE	OUTx.yz	Select output(x) level after power on(y) and after an event trigger(z); x=1-2, y=0-1, z=0-1; Normally, y/z=0 will make external relay closed, and y/z=1 make the relay open
	SPF1		Select the force unit of OUTPUT1 referred: kgf→lbf→N→kgf; and Input the force number of OUTPUT1 referred: 0 to FS
	SPF2		Select the force unit of OUTPUT2 referred: kgf→lbf→N→kgf; and Input the force number of OUTPUT2 referred: 0 to FS
AVOUT	MODE	OFF	OFF/ON=analog voltage output is off/on
		ON	
	2.5V-F		Select the controlling force unit of 2.5V referred: kgf→lbf→N→kgf Input the force value of capacity that you want to the 2.5V reference: 10%FS to 120%FS
	CAL.VO	0.0000 V	To set and check the output voltage is 0.0000/1.2500/2.5000VDC, or not.
1.2500 V			
2.5000 V			

**4.8 CELL Submenu:**

SubMenu1	Option	Default	Remark
CELL1	NO	YES	YES/NO: the CELL key can/can't choose CELL1, also means CELL1 being enabled/disabled
	YES		
CELL2	NO	NO	YES/NO: the CELL key can/can't choose CELL2, also means CELL2 being enabled/disabled
	YES		
CELL3	NO	NO	YES/NO: the CELL key can/can't choose CELL3, also means CELL3 being enabled/disabled
	YES		

**NOTE:**

When CELL1, CELL2 and CELL3 are all set to NO, the CELL1 will be forced to YES

## 5. Normal Force Measure mode

5.1 During key operation, please note to use the second function of a key need pressing the key down over 3 seconds; to input data or select menu, use

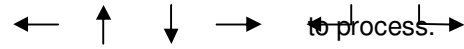

5.2 **Power on indicator:** when indicator is off, short press **ON/OFF** key to turn on;

**Power off indicator:** when indicator is on, long press **ON/OFF** key to turn off the indicator.

5.3 To select which load cell is connected to this indicator: press and release **CELL** key; after this, the indicator will display new load cell capacity and related configuration parameters will be called and used in later operations.

5.4 To send data out through RS232 or RS485: press **PRINT** key when system is stable

5.5 To zero display, presses **ZERO** key to set new zero point when the system is stable and within the zero range. Please refer its range in **COFIG-ZRO.PNT-SAZSM**

5.6 To change measure unit: Short press **UNIT** key to select lbf, kgf or Newton unit. Note: under some condition, some measure units are not available. Please refer the following tables.

5.7 To set configuration parameters, set user parameters, set current date or time, set other parameters, or do calibration mode, or test some hardware... Press **SELECT** key more than 3s to enter **SETUP** mode. After entering setup mode, the main menu item **CONFIG** will be shown first, and then you can use keys ← ↑ ↓ → ↶ ↷ to select wanted submenu and wanted menu item, select wanted choice, set wanted number, confirm and save data, or exit this mode. Please refer the "4.Operation Menu Structure".

5.8 To display FORCE or Captured PEAK data: press **SELECT** key. In PEAK display mode, what peak will be displayed is determined by setting of **USER-PEAK-DISPLAY**. Please refer following Fig.

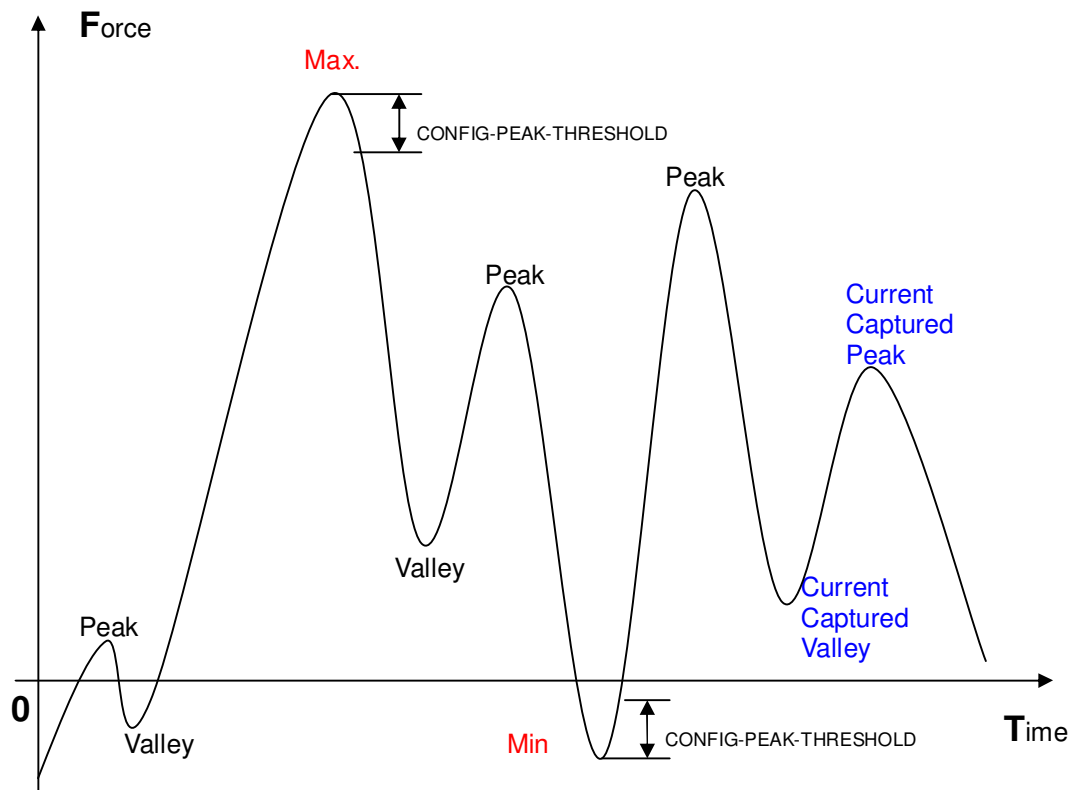

**Table1: use Kgf as primary unit:**

Calibration division value	Display division value in different weight unit that can be used		
	Kgf	Lbf	Newton
0.0001kgf	0.0001	0.0002	0.001
0.001kgf	0.001	0.002	0.01
0.01kgf	0.01	0.02	0.1
0.1kgf	0.1	0.2	1
1kgf	1	2	10
10kgf	10	20	Not available
0.0002kgf	0.0002	0.0005	0.002
0.002kgf	0.002	0.005	0.02
0.02kgf	0.02	0.05	0.2
0.2kgf	0.2	0.5	2
2kgf	2	5	20
20kgf	20	50	Not available
0.0005kgf	0.0005	0.001	0.005
0.005kgf	0.005	0.01	0.05
0.05kgf	0.05	0.1	0.5
0.5kgf	0.5	1	5
5kgf	5	10	50
50kgf	50	Not available	Not available

**Table2: use lbf as primary unit:**

Calibration division value	Display division value in different weight unit that can be used		
	kgf	lbf	Newton
0.0001lbf	Not available	0.0001	Not available
0.001 lbf	0.0005	0.001	0.005
0.01 lbf	0.005	0.01	0.05
0.1 lbf	0.05	0.1	0.5
1 lbf	0.5	1	5
10 lbf	5	10	50
0.0002 lbf	0.0001	0.0002	0.001
0.002 lbf	0.001	0.002	0.01
0.02 lbf	0.01	0.02	0.1
0.2 lbf	0.1	0.2	1
2 lbf	1	2	10
20 lbf	10	20	Not available
0.0005 lbf	0.0002	0.0005	0.002
0.005 lbf	0.002	0.005	0.02
0.05 lbf	0.02	0.05	0.2
0.5 lbf	0.2	0.5	2
5 lbf	2	5	20
50 lbf	20	50	Not available

## 6. Calibration

### Note:

- (1) Before calibrate the indicator, you should prepare a standard weight (more than 10% of FS weight) for calibration.
- (2) In following steps, to press **ON/OFF** will show “EXIT?”, and press **ON/OFF** again or press **ZERO** will exit calibration,

- 6.1 Go to setup mode, select “CAL”, then press **ZERO** to enter calibration mode.
- 6.2 After entering this mode, the number of this indicator has been calibrated will be shown first, this number will be increased by one after every calibration and calibration data saved, This counter can't be modified or erased by any other ways, it counts from 0000 to 9999, when it reaches 9999, it starts over at 0000. After the counter number being displayed, it will show “**CAL.OFF**” or “**CAL-ON**” according to the status of the sealed calibration switch is OFF or ON. If the switch is OFF, the following steps can be done, but the result will not be saved. Press **ZERO** key to go to next step.
- 6.3 When “**ZERO**” is shown, use **CELL** or **PRINT** key to select do zero point calibration (refer step6.4) or do linearity calibration (refer step6.5).
- 6.4 When **ZERO** is selected, remove all weight on scale and then press **ZERO** key to confirm, the **ZERO** will flash when in catching zero point state. After getting reasonable data, it automatically goes to step6.6
- 6.5 When **LINE** is selected, press **ZERO** key to enter linearity calibration.
  - 6.5.1 0 weight will be displayed after **CAL.P0** being shown, remove all weight on scale and then press **ZERO** to confirm to enter this zero point; the zero weight will flash in catching zero point state. After getting the reasonable zero-point data, the zero weight will become steady and then go to next step.
  - 6.5.2 When first default standard weight is displayed after **CAL.P1** being shown. It will be calibrated on standard weight for first point. Put corresponding weight (more than 10%FS weight) onto scale. The default standard weight is 100%FS. Use **CELL**, **PRINT**, **UNIT** keys to input the value of the loaded weight. Press **ZERO** key to confirm, then, the indicator will flash the input standard weight. When this weight number becomes steady, it means the stable and reasonable data corresponding to the standard weight has been gotten. Then, the indicator will automatically go to next step. If this point can't be calibrated correctly (maybe the weight load onto scale is too small, maybe the input data is incorrect...), it will display “**CAL.Er**” and return back to step6.5.1 for re-calibration.
  - 6.5.3 When **End.y** is shown and **y** is flashing, it's waiting command to exit calibration or go on next calibration. Use **CELL** or **PRINT** key to select **yes** or **no**, use **ZERO** to confirm. If **yes** is selected, it will go to step6.6 to end calibration; if **no** is selected, it will go to next step.
  - 6.5.4 When 100%FS weight is displayed after **CAL.P2** being shown. It will be calibrated on standard weight for second point. Put corresponding weight (more than 10%FS weight, and larger than the weight used on **CAL.P1**) onto scale. Next operation is same as what in step6.5.2
  - 6.5.5 When **End.y** is shown and **y** is flashing, Use **CELL** or **PRINT** key to select **yes** or **no**, use **ZERO** to confirm. Similar with doing in step6.5.3
  - 6.5.6 When third standard weight displayed after **CAL.P3** being shown. It will be calibrated on standard weight for third point. Put corresponding weight (more than 10%FS weight, and larger than the weight used on **CAL.P2**) onto scale. Next operation is same as what in step6.5.2.
  - 6.5.7 When **End.y** is shown and **y** is flashing, Use **CELL** or **PRINT** key to select **yes** or **no**, use **ZERO** to confirm. Similar with doing in step6.5.3
  - 6.5.8 When 4<sup>th</sup> standard weight displayed after **CAL.P4** being shown. It will be calibrated on standard weight for third point. Put corresponding weight (more than 10%FS weight, and larger than the weight used on **CAL.P3**) onto scale. Next operation is same as what in step6.5.2.
  - 6.5.9 When **End.y** is shown and **y** is flashing, Use **CELL** or **PRINT** key to select **yes** or **no**, use **ZERO** to

confirm. Similar with doing in step6.5.3

- 6.5.10 When 5<sup>th</sup> standard weight displayed after **CAL.P5** being shown. It will be calibrated on standard weight for 5<sup>th</sup> point. Put corresponding weight (more than 10%FS weight, and larger than the weight used on **CAL.P4**) onto scale. Next operation is same as what in step6.5.2.
- 6.6 After the indicator gets all needed data, it will calculate and store all calibration parameters to indicator, display **CAL.End**. At last, unload the system, the indicator will re-start and go back to original mode.

## **7. Force Fine-tune**

With this function, the user can adjust displayed force a little, and no need standard force. But please note:

- (1)The indicator must have been calibrated before this
- (2)The range of adjustment is “(current displayed force) x (0.9-1.1)”. it means the range is about  $\pm 10\%$
- (3)The “CONFIG-F.ADJ=YES” must be set.
- (4)Current Tare force is 0 and current measurement unit is same as setting of PRIM.U

- 7.1 To enter this mode, turn on indicator, after indicator displaying 0 force, put a load (suppose: its correct force is 1230.0lb) onto load cell, then indicator will display the load's force, say “1234.5 lb”. Press down **ON/OFF** and **ZERO** at same time until first digit flashes, this means indicator has entered into “force fine-tune” mode.
- 7.2 Use  $\uparrow$   $\downarrow$   $\rightarrow$  to input correct force (1230.0). After confirmed by **ZERO**, the active correct force will be displayed and display will stop flashing. After this, displayed force will be adjusted by this ratio (1230.0/1234.5) and this ratio will be active until next modification on it.
- 7.3 To remove the effect of this ratio, there're two ways: “7.3.1 way” and “7.3.2 way”
- 7.3.1 Do standard calibration, like in “6.CALIBRATION”
- 7.3.2 Remove all weight on scale, Press **ZERO** to make 0 displayed, Put a load onto load cell, a number will be displayed, suppose it's 1230.0lb ; Press down **ON/OFF** and **ZERO** at same time until first digit flashes, this means indicator has entered into “force fine-tune” mode.

Press  $\leftarrow$  key, the displayed weight will be restored to 1234.5, and then press  $\leftarrow$  key to confirm and exit to normal weighing mode.

## **8. View ADC output Code & calibrate input signal in mV/V**

- 8.1 In this mode, you can examine the stability of weighing system, the increment value of ADC output code corresponding to the loaded weight.

### **Note:**

- The increment of ADC code for FS force must be larger or equal to 10 times of selected display division; otherwise, the calibration cannot be properly completed. E.g. The display division is 0.1kgf. Load 100kgf standard force on the platform, the increment of ADC code should be at least more than  $10 \times 100 \text{kgf} / 0.1 \text{kgf} = 10 \times 1000 = 10000$ . In this case, the indicator can be calibrated. Otherwise, smaller division needs to be Chosen.
- The variation of ADC code should be small; otherwise, the calibration cannot properly complete also.

- 8.2 To go to this working mode, press down **SETLECT** until **CONFIG** is shown, using **CELL**, **PRINT** and **ZERO** key to go to **MISC – Code** item, press **ZERO** to enter this mode and display ADC output raw code.
- 8.3 In this mode, first press **ZERO** key can set current code as a reference zero, and then to display net code, press **ZERO** again to clear this reference and display gross code.
- 8.4 In this mode, press **PRINT** key to select displaying code that has been filtered by no-filter, filter1 or filter1

and filter2, and corresponding annunciator **N, kgf, lbf** will be lighted.

8.5 In this mode, press **UNIT** key to select displaying ADC's code or input signal in x.xxxxx mV/V unit. When display in mV/V unit, all annunciator of **N, kgf, lbf** will be lighted.

8.6 When in display signal in x.xxxxx mV/V mode, press down **UNIT** key to calibration input signal in mV/V. After enter this mode, "0mV/V" will be flashed, input 0mV/V signal to load cell connector, then press **ZERO** to confirm. When "1mV/V" or "2mV/V" is displayed, use **UNIT** key select "2mV/V" or "1mV/V", then input corresponding signal to load cell connector, then press **ZERO** to confirm. After calibration done, it backs to display signal in x.xxxx mV/V. In above steps, press **CELL** or **PRINT** key will also back to display signal in x.xxxxx mode. The end customer normally no need to do this calibration, it has been done in factory.

8.7 Press **SELECT** key to return to last menu item, press **ON/OFF** key to prepare to exit this mode

### **9. View and Calibrate Power Voltage**

9.1 In this mode, you can examine the voltage of battery, or you can examine the voltage that regulated out from AC adaptor when no battery is used, you also can calibrate the displayed voltage.

**Note:**

(1)The end customer normally no need to calibrate the displayed voltage, these have been done in factory.

(2) The normal displaying voltage is 5.6V-7.6V

9.2 To go to this working mode, press down **SELECT** until **CONFIG** is shown, using **CELL**, **PRINT** and **ZERO** key to go to **MISC – VoL** item, press **ZERO** to enter this mode and display battery voltage.

9.3 If the voltage is sure not correct, to calibrate the voltage according to following steps:

9.4 Prepare a DC power supply which output voltage can be adjusted from 5V to 8V, output current must be larger than 0.5A. Power off the indicator, move away AC adaptor, Connect this DC power to battery connector on main board, adjust voltage to about 6V, power on the indicator, enter battery voltage display mode by the way of step9.2.

9.5 Press down **UNIT** until **CAL.5.7V** is shown, adjust voltage to 6V, press **ZERO** key to confirm 5.7V calibration.

9.6 When **CAL.7V** is shown, adjust voltage to 7V, press **ZERO** key to confirm 7V calibration. When **CV.End** is shown, that means the voltage calibration is completed and then exit to display voltage.

9.7 Press **SELECT** key to return to last menu item, press **ON/OFF** key to prepare to exit this mode

### **10. View and Set Time**

10. After entering **SELECT** mode (by press down **SELECT** key more than 3s), using **PRINT** or **CELL** key to select **MISC-TIME** item, press **ZERO** to display current time.

Time display Format is: txx.xx.xx(hh-mm-ss) for LED Version, 24h format

Press down **UNIT** more than 3s to enter modification time mode. Using **PRINT**, **CELL**, **UNIT**, **ZERO** keys to modify current time. If time of no operation s more than 5s, it will automatically exit modification mode.

Press **SELECT** key to return to last menu item, press **ON/OFF** key to prepare to exit this mode

## **11. View and Set Date**

- 11.1 After entering MENU mode (by press down **SELECT** key more than 3s), using **PRINT** or **CELL** key to select **MISC-DATE** item, press **ZERO** to display current time.
- 11.2 Date display Format is: dx.x.x(yy-mm-dd) for LED Version
- 11.3 Press down **UNIT** more than 3s to enter modification date mode. Using **SETLECT**, **PRINT**, **CELL**, **UNIT**, **ZERO** keys to modify current date. If time of no operation is more than 5s, it will automatically exit modification mode.
- 11.4 Press **SELECT** key to return to last menu item, press **ON/OFF** key to prepare to exit this mode

## **12. View Firmware Version**

- 12.1 Press down **SELECT** until **CONFIG** is shown, using **PRINT** or **CELL** key to select **MISC-VER** item, press **ZERO** to display current Version.
- 12.2 Firmware Version display Format is: Vxx.yy, xx is hardware version, yy is software version
- 12.3 Press **SELECT** key to return to last menu item, press **ON/OFF** key to prepare to exit this mode

## **13. View COM2's Type**

- 13.1 Press down **SELECT** until **CONFIG** is shown, using **PRINT** or **CELL** key to select **MISC-COM2.TY** item, press **ZERO** to display COM2's type (485, 232, None)
- 13.2 Press **SELECT** key to return to last menu item, press **ON/OFF** key to prepare to exit this mode

## **14. View the Times of Load Cell was Abused**

- 14.1 Press down **SELECT** until **CONFIG** is shown, using **PRINT** or **CELL** key to select **MISC-ABUS.CNT** item, press **ZERO** to show the times of selected load cell had been abused (CLx.yyy). x=1,2,3; yyy=000-999
- 14.2 When the indicator is not sealed and press **ZERO** key more than 3s, this counter can be reset to 000.
- 14.3 Press **SELECT** key to return to last menu item, press **ON/OFF** key to prepare to exit this mode

## **15. View Zero Offset**

- 15.1 Press down **SELECT** until **CONFIG** is shown, using **PRINT** or **CELL** key to select **MISC-ZERO.OFS** item, press **ZERO** to view the offset of current zero point and calibration zero point.
- 15.2 Use **UNIT** key to view this offset in code (xxxxxxx) or in x.xxxxx mV/V format
- 15.3 Press **SELECT** key to return to last menu item, press **ON/OFF** key to prepare to exit this mode

## **16. Display Test**

- 16.1 Press down **SELECT** more than 3s to enter main menu mode, using **PRINT** or **CELL** key to select **TEST-DISP** item, press **ZERO** to enter test display mode and all segments will be lighted first.
- 16.2 In this mode, every pressing of **CELL** key will light next segment, every pressing of **UNIT** will light next digit, press **ZERO** will automatically light all segments and all digits.
- 16.3 Press **SELECT** key to return to last menu item, press **ON/OFF** key to prepare to exit this mode



**17. Keyboard and Buzzer Test**

- 17.1 Press down **SELECT** more than 3s to enter **SELECT** mode, using **PRINT** or **CELL** key to select **TEST-key** item, press **ZERO** to enter test keypad mode, and **key. –** will be displayed.
- 17.2 In this mode, press a key, the value of this key will be displayed on - - position and buzzer will beep..
- 17.3 Press **SELECT** key to return to last menu item, press **ON/OFF** key to prepare to exit this mode

**18. Input Test**

- 18.1 Press down **SELECT** until **CONFIG** is shown, using **PRINT** or **CELL** key to select **MISC-INPUT** item, press **ZERO** to show level (0/1) of input line1. "INP1.0/1" will be shown
- 18.2 Use **CELL**, **PRINT** to view the level of input line1,2,3,4
- 18.3 Press **SELECT** key to return to last menu item, press **ON/OFF** key to prepare to exit this mode

**19. Output Test**

- 19.1 Press down **SELECT** until **CONFIG** is shown, using **PRINT** or **CELL** key to select **MISC-OUTPUT** item, press **ZERO** to output 0/1 on output line1. "OUT1.0/1" will be displayed
- 19.2 Use **CELL** key to select output 0 or 1 on output line. Use **PRINT** key to select test output line1 or line2.
- 19.3 Press **SELECT** key to return to last menu item, press **ON/OFF** key to prepare to exit this mode

**20. Serial Port1/2 (COM1/2) Receiving Test**

- 20.1 Before test the receiving function of **COM1** or **COM2**, a cable is need to connect a PC and this indicator, and a software that is similar with Super Terminal of Windows is also need to run on PC to send bytes to this indicator. Please note: testing uses **USER-COM1/2-BAUD.RT** setting baud rate and 8N1 byte format, Hex data.
- 20.2 Press down **SELECT** more than 3s to enter **SELECT** mode, using **PRINT** or **CELL** key to select **TEST-COM1.RD** or **TEST-COM2.RD** item, press **ZERO** to enter test COM1/2 receiving function, and **rd1.--** or **rd2.–**will be displayed first.
- 20.3 In this mode, received hex data (0x00 – 0xff) will be displayed on – position.
- 20.4 Press **SELECT** key to return to last menu item, press **ON/OFF** key to prepare to exit this mode

**21. Serial Port1/2(COM1/2) Transmitting Test**

- 21.1 Before test the transmitting function of **COM1** or **COM2**, a cable is need to connect a PC and this instrument, and a software that is similar with Super Terminal of Windows is also need to run on PC to receive bytes from this instrument. Please note: testing uses **USER-COM1/2-BAUD.RT** setting baud rate and 8N1 byte format, Hex data.
- 21.2 Press down **SELECT** more than 3s to enter **SELECT** mode, using **PRINT** or **CELL** key to select **TEST-COM1.TD** or **TEST-COM2.TD** item, press **ZERO** to enter test COM1/2 transmitting function, and **td1.–**or **td2.–**will be displayed first.
- 21.3 In this mode, transmitted hex data (0x00 – 0xff) will be displayed on – position, and **PRINT**, **CELL**, **UNIT**, **ZERO** keys can be used to modify transmitted data.
- 21.4 Press **SELECT** key to return to last menu item, press **ON/OFF** key to prepare to exit this mode

**22. Remote Input Function Selection**

- 22.1 Press down **SELECT** until **CONFIG** is shown, using **PRINT** or **CELL** key to select **IN.OUT-INPUT** item, press **ZERO** to display original function of input line1. It is displayed in "Inx.yyyy) format. X(=1,2,3,4) is the number of input line, yyyy(=NONE, SELE, CELL, PRNT, UNIT, ZERO, OFF) is the function of input line x. Every input function can be defined to SELECT,CELL,PRINT,UNIT,ZERO, or OFF.
- 22.2 Use **CELL** key to change input line; Use **PRINT** key to select the function of this line, Use **ZERO** key to confirm and save.
- 22.3 Press **SELECT** key to return to last menu item, press **ON/OFF** key to prepare to exit this mode

**23. Output Setting**

- 23.1 Press down **SELECT** until **CONFIG** is shown, using **PRINT** or **CELL** key to select **IN.OUT-OUTPUT** item, press **ZERO** to enter setting mode.
- 23.2 Use **CELL** or **PRINT** key to select **MODE** (setting output mode) or **SPF1** or **SPF2** ("Set Point Force", setting the corresponding data of output). Use **ZERO** to confirm.
- 23.3 When "OUTx.yz" is shown, Use **CELL** key to change output line number(x), Use **PRINT** key to change level after power on (y) and after an event trigger(z); x=1-2, y=0-1, z=0-1; Normally, y/z=0 will make external relay closed, and y/z=1 make the relay open. Y=0/1 means after the indicator power on, the output level is 0/1, z=0/1 means if current display force is over the setting data (SPF1/2), the output level is 0/1. Use **ZERO** to confirm.
- 23.4 When "SPF1/2" is shown, use **ZERO** to enter set set-point1/2 data mode. When "UNIT.kgf/lbf/n" is shown, use **CELL**, **PRINT**, or **UNIT** key to select unit of input force number. After this, use **CELL**, **PRINT**, **UNIT** key to input force number, and then use **ZERO** to confirm and save them.
- 23.5 In normal force measure mode, if SPF1 or SPF2 is set bigger than 0, the electronic level on output line will change according to the setting of OUTx.yz.
- 23.6 Press **SELECT** key to return to last menu item, press **ON/OFF** key to prepare to exit this mode

**24. Analog Voltage Output Setup**

**Note:** The current draw from analog voltage output should be less than 2.5mA, that means the resistor added on this output connector should more than 1K: !

- 24.1 Press down **SELECT** until **CONFIG** is shown, using **PRINT** or **CELL** key to select **IN.OUT-AVOUT** item, press **ZERO** to enter this mode.
- 24.2 Use **CELL** or **PRINT** key to select **MODE** (set analog voltage output is enable or disable) or **2.5V-F** (set the force number of 2.5V output) or **CAL.VO** (calibrate the output analog voltage). Use **ZERO** to confirm.
- 24.3 After enter **MODE** item, use **CELL** and **PRINT** to enable or disable output analog voltage, Use **ZERO** to confirm.
- 24.4 After enter **2.5V-F** item, "UNIT.kgf/lbf/n" will be shown, use **CELL**, **PRINT**, or **UNIT** key to select unit of input force number, then use **CELL**, **PRINT**, **UNIT** to input force number that is corresponding to the 2.5V analog voltage output, Use **ZERO** to confirm.
- 24.5 When **CAL.VO** is shown, it means calibrate output voltage. Before this, a high accuracy voltage meter is need. After enter this calibration mode by pressing **ZERO** key, "0.0000V" will be shown, that means output

0.0000V is ready to be calibrated. If the reading on voltage meter is not 0.0000V, use **CELL** or **PRINT** to adjust the reading to 0.0000V, then use **ZERO** key to finish 0.0000V output calibration. Similarly, do calibration on 1.2500V and 2.5000V. When adjust the output voltage, the output code to DAC (Digit to Analog Converter) will be displayed temporarily and then back to display output voltage.

24.6 Press **SELECT** key to return to last menu item, press **ON/OFF** key to prepare to exit this mode

## 25. Details about Serial Communication

25.1 COM1 is RS232, communication wires come from RS232 connector, and **TXD1**, **RXD1** and **GND** are used.

25.2 COM2 can be RS232 or RS485, if used as RS232, communication wires come from RS232 connector, and **TXD2**, **RXD2** and **GND** are used, if used as RS485, communication wires come from RS485 connector, and **A** and **B** are used (if need GND or +5VCC1 can be used).

Please refer to section 26.2, 26.3.4-5, 26.3.7-9 for jumper connector details.

25.3 The baud rate and byte format is set by **USER-COM1/2-BAUD.RT** and **USER-COM1/2-BYT.FMT**. Responses to serial commands will be immediate, or within one force measure cycle of the indicator. One second should be adequate for use as a time-out value by remote (controlling) device.

25.4 The length of each item in a transition string:

25.4.1 Reading data --- 6bytes

Data polarity ----1byte: “-” for negative, and followed the first digit; “ ” for positive.

Decimal point ---1byte: “.”

Measure unit ----1-3bytes: “ lbf”, “ kgf”, “N”, left aligned

Current status—4bytes

25.4.2 If the force is overcapacity, the indicator will return eight “^” characters (the field of polarity, decimal point, force data is filled by “^”).

25.4.3 If the force is under capacity, it will return eight “\_” characters (the field of polarity, decimal point, and force data is filled by “\_”).

25.4.4 If the zero point is error, it will return eight “-” characters (the field of polarity, decimal point, and force data is filled by “-”).

25.4.5 Useless leading 0 before digits is suppressed. Reading weight is right aligned.

25.5 Key to symbols used

<LF>	Line Feed character (hex 0AH)
<CR>	Carriage Return character (hex 0DH)
<ETX>	End of Text character (hex 03H)
<SP>	Space (hex 20H)
H <sub>1</sub> H <sub>2</sub> H <sub>3</sub> H <sub>4</sub>	Four current status bytes
<P>	Polarity character: “-” or “ ”
W <sub>1</sub> ---W <sub>6</sub>	Reading data
<DP>	Decimal point
U <sub>1</sub> U <sub>2</sub> U <sub>3</sub>	Measure units, kgf, lbf, N
<Add>	Address of indicator
<Prompt>	Prompt of output content

**The bit definition of H<sub>1</sub>H<sub>2</sub>H<sub>3</sub> H<sub>4</sub>:**

Bit	Byte 1 (H1)	Byte 2 (H2)	Byte 3 (H3)	Byte 4 (H4)
0	0=stable	0= not under capacity	0=output1 is set low	0=input1's level is low
	1= not stable	1= under capacity	1=output1 is set high	1=input1's level is high
1	0= not at zero point	0= not over capacity	0=output2 is set low	0=input2's level is low
	1= at zero point	1= over capacity	1=output2 is set high	1=input2's level is high
2	0=RAM ok	0=ROM ok	0= force mode	0=input3's level is low
	1= RAM error	1=ROM error	1= peak mode	1=input3's level is high
3	0= eeprom OK	0=calibration ok	0=initial zero ok	0=input4's level is low
	1= eeprom error	1=calibration error	1=initial zero error	1=input4's level is high
4	always 1	always 1	always 1	always 1
5	always 1	always 1	always 1	always 1
6	always 0	always 1	always 1	always 0
7	parity	Parity	parity	Parity

25.6 Communication when **USER-COM1/2-LAYOUT** is set to **SINGLE**:

25.6.1 Commands and response

25.6.1.1 Command: **W<CR>** (57h 0dh), request current reading

Response:

- <LF> ^^^^^^^^ U<sub>1</sub>U<sub>2</sub> U<sub>3</sub><CR><LF> H<sub>1</sub>H<sub>2</sub>H<sub>3</sub> H<sub>4</sub><CR><ETX>---over capacity
- <LF> \_ \_ \_ \_ \_ \_ \_ \_ U<sub>1</sub>U<sub>2</sub> U<sub>3</sub><CR><LF> H<sub>1</sub>H<sub>2</sub>H<sub>3</sub> H<sub>4</sub><CR><ETX>---under capacity
- <LF> - - - - - - - - U<sub>1</sub>U<sub>2</sub> U<sub>3</sub> <CR><LF> H<sub>1</sub>H<sub>2</sub>H<sub>3</sub> H<sub>4</sub><CR><ETX>---zero-point error

**Note:** U<sub>1</sub>U<sub>2</sub> U<sub>3</sub> is 1 or 3 bytes according to current unit: kgf, lbf, N

- <LF><P>W<sub>1</sub>W<sub>2</sub>W<sub>3</sub>W<sub>4</sub>W<sub>5</sub><DP>W<sub>6</sub> U<sub>1</sub>U<sub>2</sub> U<sub>3</sub> <CR><LF> H<sub>1</sub>H<sub>2</sub>H<sub>3</sub> H<sub>4</sub> <CR><ETX>---normal data

**Note:** The decimal point position is determined by **CONFIG-PRIM.D**

25.6.1.2 Command: **S<CR>** (53h 0dh) , request current status

Response: <LF> H<sub>1</sub>H<sub>2</sub>H<sub>3</sub> H<sub>4</sub><CR><ETX>

25.6.1.3 Command: **Z<CR>** (5ah 0dh)

Response: Zero function is activated (simulate **ZERO** key) and it returns to current indicator status.

<LF> H<sub>1</sub>H<sub>2</sub>H<sub>3</sub>H<sub>4</sub><CR><ETX>

If ZERO function cannot be activated, it will return to current indicator status.

25.6.1.4 Command: **U<CR>** (55h 0dh)

Response: Changes units of measure (simulate **UNIT** key) and return indicator status with **new** units,

The new measure unit should be allowed to use

<LF> U<sub>1</sub>U<sub>2</sub> U<sub>3</sub><CR><LF> H<sub>1</sub>H<sub>2</sub>H<sub>3</sub> H<sub>4</sub><CR><ETX>

25.6.1.5 Command: **L<CR>** (4ch 0dh)

Response: Select next load cell to work (simulate **CELL** key), and returns indicator status.

<LF> H<sub>1</sub>H<sub>2</sub>H<sub>3</sub>H<sub>4</sub><CR><ETX>

25.6.1.6 Command: **X<CR>** (58h 0dh)

Response: power off the indicator, just like press down the **ON/OFF** key to turn off the indicator.

25.6.1.7 Command: all others

Response: Unrecognized command <LF>? <CR><ETX>

25.6.2 Summary of Command and Response:

Command		Response
ASCII	HEX	
<b>W&lt;CR&gt;</b>	57 0d	Read scale weight: <input type="checkbox"/> <LF> ^^^^^^^^ U <sub>1</sub> U <sub>2</sub> U <sub>3</sub> <CR><LF> H <sub>1</sub> H <sub>2</sub> H <sub>3</sub> H <sub>4</sub> <CR><ETX> ---over capacity <input type="checkbox"/> <LF> _____ U <sub>1</sub> U <sub>2</sub> U <sub>3</sub> <CR><LF> H <sub>1</sub> H <sub>2</sub> H <sub>3</sub> H <sub>4</sub> <CR><ETX> ---under capacity <input type="checkbox"/> <LF> ----- U <sub>1</sub> U <sub>2</sub> U <sub>3</sub> <CR><LF> H <sub>1</sub> H <sub>2</sub> H <sub>3</sub> H <sub>4</sub> <CR><ETX> ---zero-point error <input type="checkbox"/> <LF><p>W <sub>1</sub> W <sub>2</sub> W <sub>3</sub> W <sub>4</sub> W <sub>5</sub> <Dp>W <sub>6</sub> U <sub>1</sub> U <sub>2</sub> U <sub>3</sub> <CR><LF>H <sub>1</sub> H <sub>2</sub> H <sub>3</sub> H <sub>4</sub> <CR><ETX> ---normal data
<b>S&lt;CR&gt;</b>	53 0d	<LF> H <sub>1</sub> H <sub>2</sub> H <sub>3</sub> H <sub>4</sub> <CR><ETX>; read indicator status
<b>Z&lt;CR&gt;</b>	5a 0d	<LF> H <sub>1</sub> H <sub>2</sub> H <sub>3</sub> H <sub>4</sub> <CR><ETX> ; simulate ZERO key
<b>U&lt;CR&gt;</b>	55 0d	<LF> U <sub>1</sub> U <sub>2</sub> U <sub>3</sub> <CR><LF> H <sub>1</sub> H <sub>2</sub> H <sub>3</sub> H <sub>4</sub> <CR><ETX>; simulate UNIT key
<b>L&lt;CR&gt;</b>	4c 0d	<LF> H <sub>1</sub> H <sub>2</sub> H <sub>3</sub> H <sub>4</sub> <CR><ETX>; simulate SELECT key
<b>X&lt;CR&gt;</b>	58 0d	power off the indicator, simulate OFF key
others		<LF>? <CR><ETX>

25.7 Communication when **USER-COM1/2-LAYOUT** is set to **MULTIPLE**:

25.7.1 Output string frame:

<LF><Add><Prompt><p>W<sub>1</sub>W<sub>2</sub>W<sub>3</sub>W<sub>4</sub>W<sub>5</sub><Dp>W<sub>6</sub> U<sub>1</sub>U<sub>2</sub> U<sub>3</sub> <CR>

..... --- Line number and content are determined by setting of **USER-OUT1/2-xxxx**

<LF><Add><Prompt>H<sub>1</sub>H<sub>2</sub>H<sub>3</sub> H<sub>4</sub><CR> --- **USER-OUT1/2-STATUS** is set to **YES**

.....

<LF><Add><CR> --- **USER-OUT1/2-LINE** is set to **LINE1...9**

..... The number of blank lines is determined by **USER-OUT1/2-LINE** setting

<ETX> --- Last byte of string frame

## 25.7.2 Caution:

- (1)The decimal point position is determined by **CONFIG-PRIM.D**
- (2)The unit position and bytes is determined by which current unit is used.
- (3)The details of <Prompt> refer to the content in 4.3**USER Submenu**.
- (4)If **USER-COM2-EN.ADDR** is set to **NO**, no <Add> will be output.
- (5)In continues output mode, if **USER-COM1/2-LAYOUT** is set to **MULTIPLE**, and many contents are selected to output, the output contents from COM1 or COM2 may not catch up with the data processed in indicator, So, if you want to watch “real time” data, you need to select fewer output contents and set higher baud rate for COM1 or 2.

(2012) Examples of some layout when **USER-OUT1-xxxx** is set to **YES**:

```

IND. ID:      123456
CELL No. :    1
CELL TYPE:    COMPRESS
MAES.TYPE:    FORCE
FORCE:        123.34 lbf
PEAK:         150.60 lbf
VALLEY:       10.78lbf
Max:          192.24lbf
Min:          1.56lbf
DATE:         2012-02-12
TIME:         12:34:56
A/D CODE:     982463
INPUT:        1.23034 mV/V
VOLTAGE:      6.7V
STATUS:       bpg2

```

25.7.4 The broadcast rate of com1 or com2 is determined by following factors:

25.7.4.1 The A/D speed: that is 80Hz: once a new conversion ends and a new data is got, the MCU (Micro-Control Unit) will prepare the new data for COM1 or COM2, but if last data is not sent out completely, it will wait, and the broadcast rate will be slow down.

25.7.4.2 The contents that you choose to output in **USER-OUT1/2**: the more contents, the more time will be take to output them

25.7.4.3 One COM or two COMs are used: if two COMs are used, the broadcast rate is determined by the one that takes more time for transmitting and receiving

25.7.4.4 The baud rate: the higher baud rate choose, the less time takes by transceiver, the higher broadcast rate maybe get

25.7.4.5 Output mode: only **USER-COM1/2-OUT.MOD=CONT/PRT.CMD**, the highest rate maybe be gotten

25.7.4.6 The time spent on calculation force, preparing output contents and received command (if **USER-COM1/2-OUT.MOD=CMD**) processing: more time it takes, slower the broadcast rate is.

**So**, the highest rate is 80Hz, even if a highest baud rate, a least output contents, one COM are selected. For example, If you only use COM1, baud rate is set to 57600bps, and following contents

(Max 25 bytes a line) selected to be output when **USER-COM1/2-LAYOUT=MULTPL** or **USER-COM1/2-LAYOUT=SINGLE** set to be used, then you can get up to 80Hz broadcast rate .

FORCE: 1235.68lbf

25.8 Communication when **USER-COM1/2-LAYOUT** is set to **EDX**:

25.8.1 Output string frame:

<sp>W<sub>1</sub>W<sub>2</sub>W<sub>3</sub>W<sub>4</sub><sp> U<sub>1</sub>U<sub>2</sub> U<sub>3</sub> <CR><LF>

## 26. Sockets and Jumpers

### 26.1 Back View of Indicator:

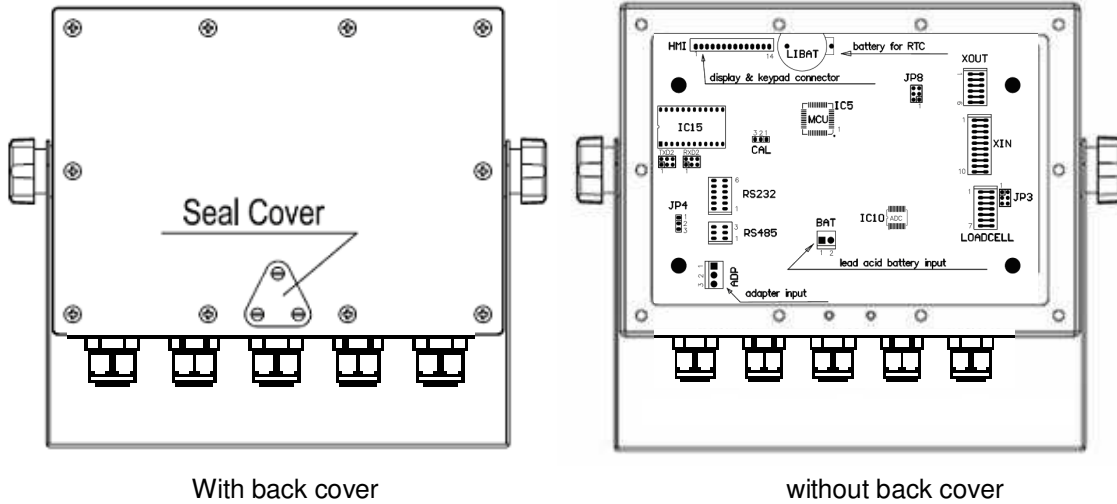

### 26.2 Sockets and Jumpers on Main Board

#### 26.2.1 Without Analog Voltage Output Board:

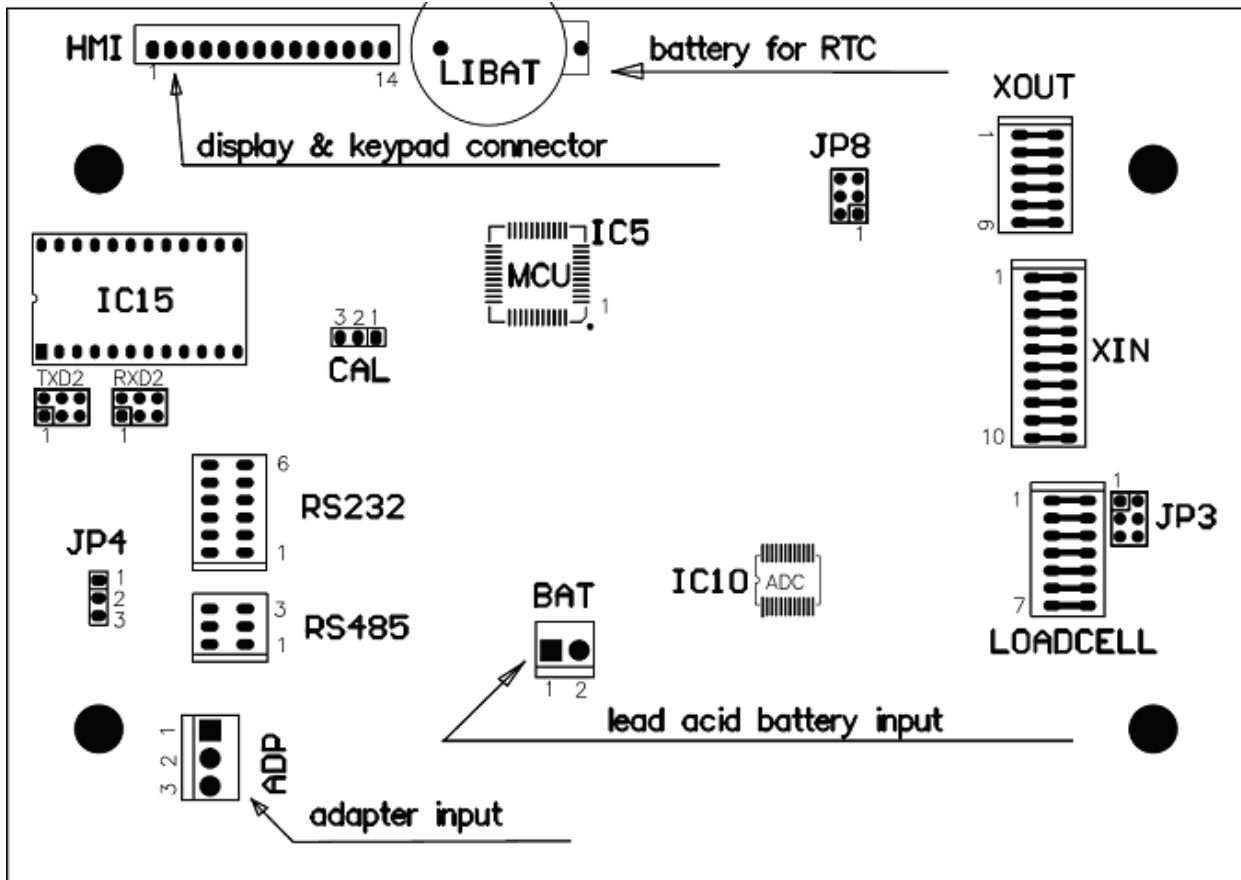



26.2.2 Analog Voltage Output Board installed:

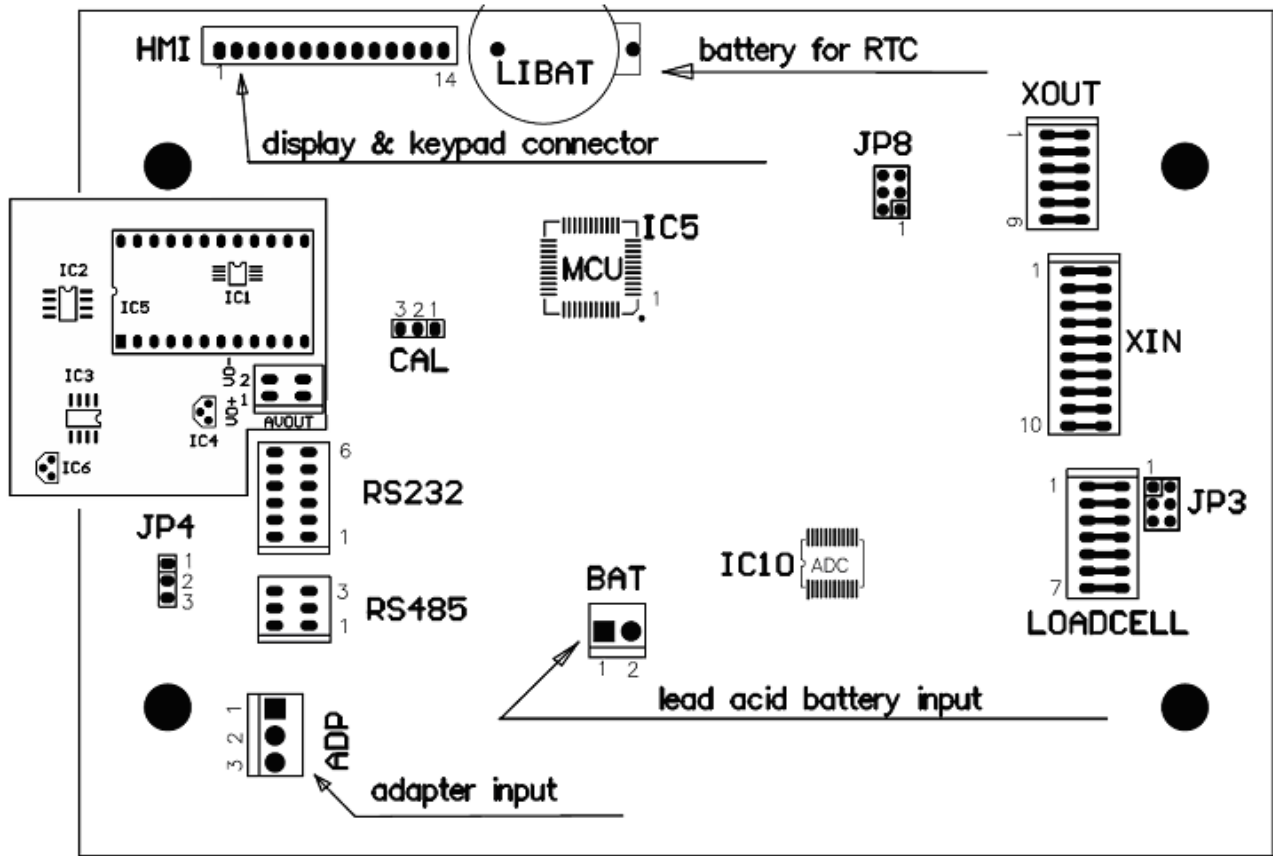

26.3 Definition of Sockets and Jumpers: (make sure the no.1 pin position, refer to 26.2.2)

26.3.1 ADP---adapter power input connector

PIN #	DEFINITION	IN/OUT/POWER	ELECTRICAL LEVEL
1	Adapter input voltage +	Power input	12Vdc(10.5-15Vdc,≥0.5A)
2	Adapter input voltage – (GND)	Power ground	0Vdc
3	Shell Earth		

26.3.2 BAT---Battery power input connector

PIN #	DEFINITION	IN/OUT/POWER	ELECTRICAL LEVEL
1	Battery input voltage +	Power input	5.6-7.2Vdc (6V lead acid battery)
2	Battery input voltage – (GND)	Power ground	0Vdc

26.3.3 LOADCELL Connector:

PIN #	DEFINITION	IN/OUT/POWER	ELECTRICAL LEVEL
1	Excitation +	Power output	5±0.3 Vdc (≤0.12A)
2	Sense +	Power input	5±0.3 Vdc
3	Excitation-	Power ground	≤0.5 Vdc
4	Sense -	Power input	0Vdc
5	Signal +	Signal Input	2.5±0.3 Vdc
6	Signal -	Signal Input	2.5±0.3 Vdc
7	Shield	-	-

If a pigtail (an around 30cm cable with a 7-pin female connector) is used for load cell interface, the cable pin-outs are:

- Pin1:** Sense +
- Pin2:** Sense –
- Pin3:** Excitation –
- Pin4:** Signal +
- Pin5:** Excitation +
- Pin6:** Signal -
- Pin7:** Ground

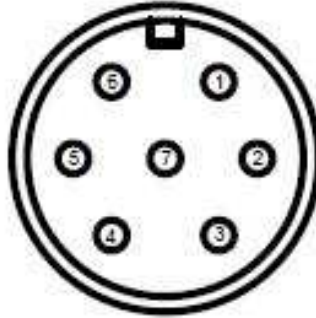

26.3.4 RS232 Connector:

PIN #	DEFINITION	IN/OUT/POWER	ELECTRICAL LEVEL
1	COM1 Receive	Input	-12 to +12Vdc
2	COM1 Transmit	Output	-12 to +12Vdc
3	GND	Power ground	0Vdc
4	GND	Power ground	0Vdc
5	COM2 Receive	Input	-12 to +12Vdc
6	COM2 Transmit	Output	-12 to +12Vdc

26.3.5 RS485 Connector:

PIN #	DEFINITION	IN/OUT/POWER	ELECTRICAL LEVEL
1	RS485 signal A	Input/output	0Vdc
2	RS485 signal B	Input/output	0-5Vdc
3	GND	Power ground	0-5Vdc





26.3.6 CAL Jumper set:

CONNECTED PINS	FUNCTION
1-2	Calibration Enabled
2-3	Calibration Disabled







26.3.7 JP4 Jumper set:

CONNECTED PINS	FUNCTION
1-2	RS485 terminal 120ohm resistor on board is disabled
2-3	RS485 terminal 120ohm resistor on board is enabled



26.3.8 JP8 Jumper Connector:

CONNECTED PINS	FUNCTION
 <p>1</p>	COM2 is used as RS232
 <p>1</p>	COM2 is used as RS485
 <p>1</p>	COM2 is not used
 <p>1</p>	COM2 is not used

26.3.9 RXD2 and TXD2 Jumper Connector:

CONNECTED PINS		FUNCTION
TXD2	RXD2	
 <p>1</p>	 <p>1</p>	COM2 is not used
 <p>1</p>	 <p>1</p>	COM2 is used as RS232
 <p>1</p>	 <p>1</p>	COM2 is used as RS485

26.3.10 JP3 Jumper Connector:

CONNECTED PINS	FUNCTION
 <p>1</p>	JP3-2,3 pin connected: 4 wires Load cell is used
 <p>1</p>	JP3-1,2 pin connected: 6 wires load cell is used

26.3.11 AVOUT Connect on Analog Voltage Output Sub-Board:

CONNECTED PINS	FUNCTION
1	Analog Voltage Output +
2	Analog Voltage Output – (Internal Power GND)

**Note:**

The current draw from 1-2 connector should be less than 2.5mA, that means the resistor added between 1-2 connector should more than 1K: !

26.3.12 XIN (Remote Input) Connector:

26.3.12.1 Pin Definition

PIN #	DEFINITION	IN/OUT/POWER	ELECTRICAL LEVEL
1	Internal Power output +	Power output	5 – 8Vdc ( $\leq 0.1A$ )
2	Input1+	input	5-24Vdc
3	Input1-	input	0Vdc
4	Input2+	input	5-24Vdc
5	Input2-	input	0Vdc
6	Input3+	input	5-24Vdc
7	Input3-	input	0Vdc
8	Input4+	input	5-24Vdc
9	Input4-	input	0Vdc
10	Internal Power output -	Power GND	0 Vdc

26.3.12.2 Connection Example When External Power Supply:

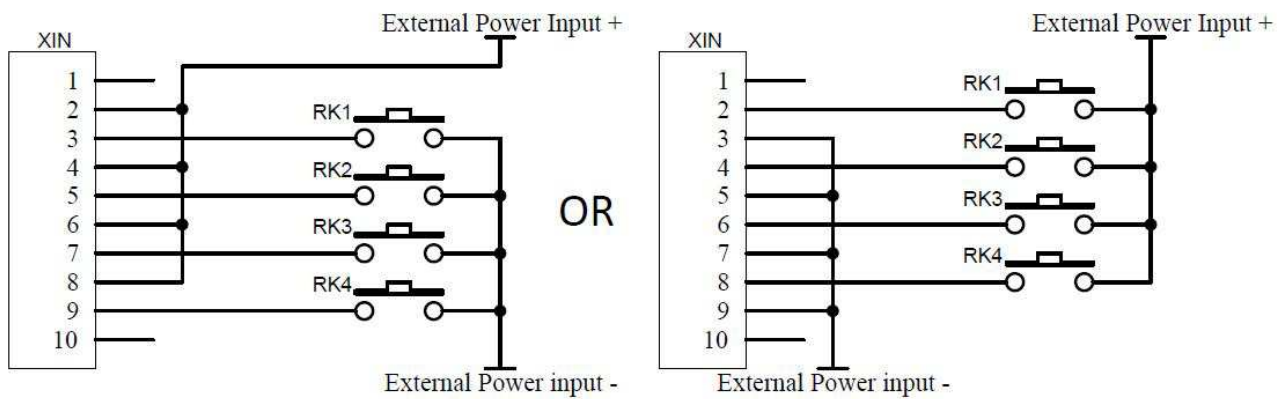

The remote keys RK1-RK4 also can be transistor, and the remote keys connection is isolated to internal circuit.

26.3.12.3 Connection Example When Internal Power Supply (not recommended):

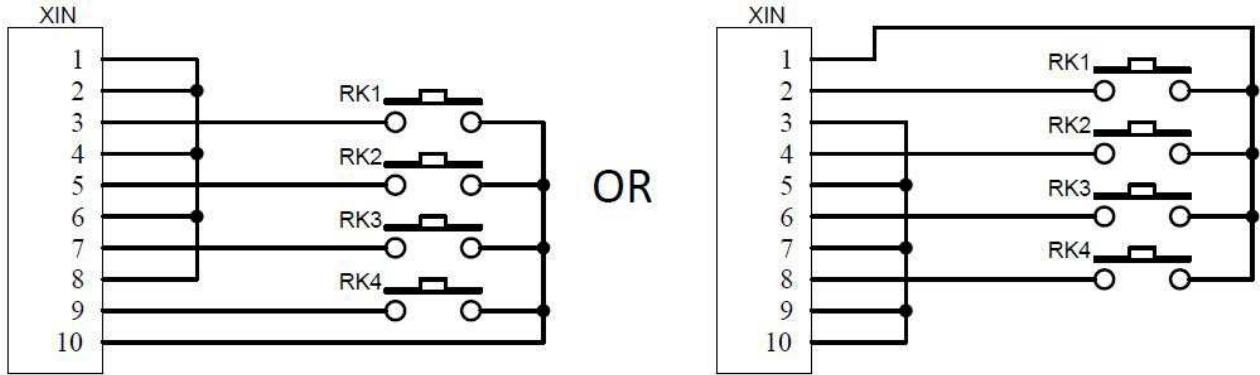

The remote keys RK1-RK4 also can be transistor, and the remote keys connection is not isolated to internal circuit.

26.3.13 XOUT (Output) Connector:

26.3.13.1 Pin Definition

PIN #	DEFINITION	IN/OUT/POWER	ELECTRICAL LEVEL
1	Internal Power output -	Power GND	0 Vdc
2	Output driver COM / External Power input -	Emitter of Output NPN Transistor 1 and 2	
3	Output driver 1	Output, open NPN Transistor Collector 1	Vce max 24Vdc; Ic (sink ) max 0.5A.
4	Output driver 2	Output, open NPN Transistor Collector 2	Vce max 24Vdc; Ic (sink ) max 0.5A.
5	External Power input +	Power input	5 – 24 Vdc
6	Internal Power output +	Power output	5 – 8 Vdc (≤0.1A)

26.3.13.2 Connection Example When External Power Supply:

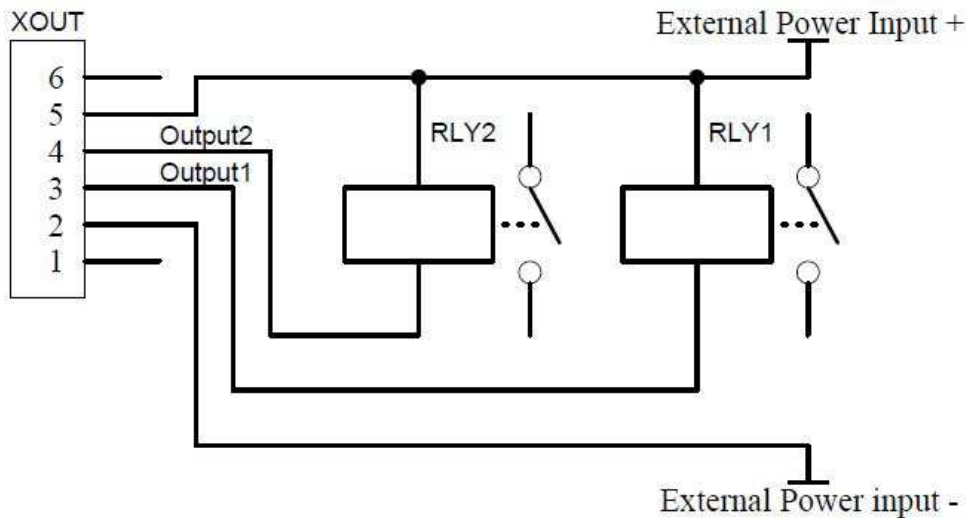

The external power is isolated by optocoupler to internal circuit in this situation. The Max. voltage of external power should not be over than 24VDC, and should to keep the Max. current of output1 or output2 less than 0.5A .

## 26.3.13.3 Connection Example When Internal Power Supply (not recommended):

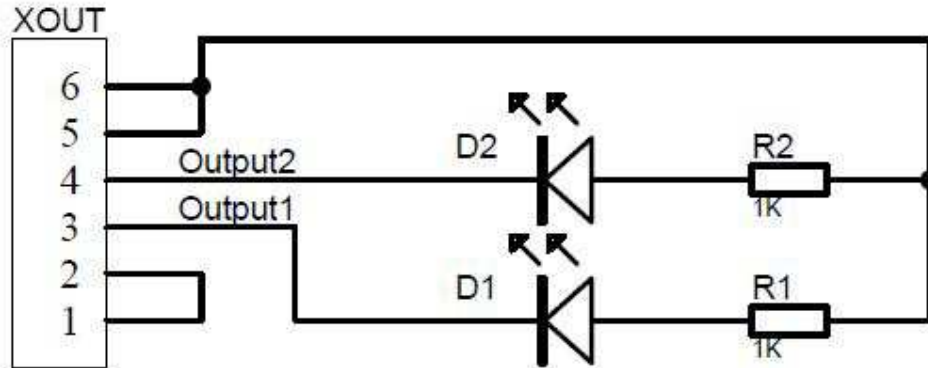

When use internal power is used, the total current of output1 and output 2 draw (sink) must be less than 0.1A, that means heavy extra load should not be added on internal power! As above drawing, only light load can be used in this condition.

## 27. Meaning of Some Symbols and Troubleshooting

### 27.1 Meaning of Symbols:

- 27.1.1 **0**----- ----- Zero is over the setting range
- 27.1.2 **0**----- ----- Zero point is below the setting range
- 27.1.3 **Ad**----- ----- Signal to ADC is over max. range)
- 27.1.4 **Ad**----- ----- Signal to ADC is below min. range
- 27.1.5 ----- ----- Frce is over upper limitation, or display data is over limitation
- 27.1.6 ----- ----- Force is below lower limitation
- 27.1.7 **EEP.E1** ----- CONFIG or CAL parameters are not correctly set
- 27.1.8 **EEP.E2** ----- USER parameter is not correctly set
- 27.1.9 **Lo.bAt** ----- Battery voltage is lower than setting.
- 27.1.10 **CAP.---** ---- Next displaying content is Capacity
- 27.1.11 **CAP.ER** ----- Setting Capacity is over display range
- 27.1.12 **CAL.Px** ----- Calibration on point(x)
- 27.1.13 **CAL.OFF** ----- Calibration Seal Switch is on OFF position
- 27.1.14 **CAL.ON** ----- Calibration Seal Switch is on ON position
- 27.1.15 **CAL.Er** ----- Calibration error, maybe input data or puton load is incorrect, unstable, un-linear
- 27.1.16 **CAL.End** ----- Calibration is end
- 27.1.17 **OFF** ----- Power OFF the indicator

**27.2 Troubleshooting**

<b>SYMPTOM</b>	<b>PROBABLE CAUSE</b>	<b>REMEDY</b>
<b>Ad</b> -----	Load cell wires to indicator are incorrectly connected, or shorted, or opened; or ADC, load cell are damaged	Make sure wires are ok and correctly connected. Replace load cell or ADC chip, Service required.
<b>Ad</b> -----		
<b>0</b> -----	Weight reading exceeds Power On Zero limit.	Make sure cell platform is empty. Perform zero calibration.
<b>0</b> -----	Weight reading below Power On Zero limit.	Install platform on cell. Perform zero calibration.
-----	Weight reading exceeds Overload limit, or The weight value cannot be displayed in the current unit of measure because it exceeds 6 digits..	Reduce load on cell until force value can be displayed. Use a more appropriate unit of measure. Re-set some parameters of CONFIG or UAER.
-----	Weight reading below Under load limit.	Install platform on load cell. Perform zero calibration
<b>EEP.E1</b>	CONFIG or CAL parameters are not correctly set	Re-set items in CONFIG, do calibration
<b>EEP.E2</b>	USER parameter is not correctly set	Re-set items in USER
<b>CAP.ER</b>	Setting Capacity is over display range	Decrease PRIM.N or PRIM.d to make sure capacity not more than 6 digit(ignore decimal point)
<b>CAL.Er</b>	Calibration error, maybe input data or loaded weight is too small, too big, unstable, un-linear	Input correct data, load correct weight onto platform, Service required
<b>Not turn on.</b>	Power cord not plugged in or properly connected. Power outlet not supplying electricity. Battery discharged. Other failure.	Check power cord connections. Make sure power cord is plugged into the power outlet. Check power source. Replace batteries. Service required.
Cannot zero the display or will not zero when turned on.	Load on cell exceeds allowable limits. Load on cell is not stable. Load cell damaged.	Remove load on cell. Wait for cell become stable. Service required.
Cannot display weight in desired weighing unit.	Unit not set to enable	Enable unit in CONFIG-UNITS

Battery symbol is empty or <b>Lo.bAt</b> is shown	Batteries are discharged.	Charge batteries
---	---------------------------	------------------

**28. Display Character**

ASCII	LCD/LED Show	ASCII	LCD/LED Show	ASCII	LCD/LED Show
0		A		N	
1		B		O	
2		C		P	
3		D		Q	
4		E		R	
5		F		S	
6		G		T	
7		H		U	
8		I		V	
9		J		W	
		K		X	
		L		Y	
		M		Z	



**29. Packing List**

No.	CONTENT	QTY
1	Indicator	1
2	User manual	1
3	Swivel bracket	1
4	6V lead-acid battery (optional)	1

**30. Version History**

VERSION	DESCRIPTION	DATE
V1.0	Initial version	2012-03-05
V1.1	Add section 1.14/15/16; modify the picture section 26.1	2012-05-02
V1.2	Modify some default settings	2012-05-15
V1.3	(1)Add pigtail for load cell interface definition in 26.3.3 section (2)Add section 25.7.4 about broadcast rate of RS232	2012-05-31
V1.4	(1)Add option of output prompt of every line in USER-OUT1/2 menu (2)Add EDX protocol in section 25.8 (3)Add Calibration in negative direction	2012-12-21
V02.02	(1) Change the default setting	2013-09-16
<b>V02.03</b>	<b>(1) Add CELL menu</b>	<b>2014-05-12</b>