

---

---

## 7.0 Specifications

### GENERAL PARAMETERS

Frequency range	0 to12,500 FPM (flashes per minute)
Power supply	24 VDC (+/-20%) / 40 W DIN 41524 5-pin standard connector Universal power supply unit available
External trigger input	3 to 30 V/max. 5 mA Isolated optocoupler DIN 41524 5-pin standard connector U <sub>out</sub> = U <sub>in</sub> , max. 200 mA Switchable trigger input
Trigger output	For parallel connection

### FLASH PARAMETERS

Flash duration	<10 µs
Light intensity/sharpness	adjustable, on rotary knob
Light intensity single flash	approx. 20 megalux/12"/30cm
Light intensity	2,500 Lux/12"/30cm
Illumination area	12 x 20" (30 x 50 cm)
Flash colour approx.	6000 to 6500 K
Flash energy	2,000 mJ (@ ≤ 900 FPM)

### HOUSING

Material	Aluminium
Dimensions	9.1 x 5.1 x 4.4" (230 x 130 x 112mm)
Weight	3.09 lbs. (1,400g)

### AMBIENT CONDITIONS

Ambient temperature	32° to104°F (0° to 40°C)
Storage temperature	-13° to 158°F (-25° to 70°C)
Humidity max.	95% non-condensing

### CERTIFICATIONS

CE certification

---

---

## Table of Contents

1.0 Introduction .....	2
1.1 Package Contents .....	
2.0 Safety Instructions.....	2
3.0 Overview .....	3
4.0 Assembly and Connection .....	4
4.1 Typical Connection Examples .....	
5.0 Operation .....	6
6.0 Flash Tube Replacement .....	7
7.0 Specifications .....	8
8.0 Warranty .....	back cover

## 1.0 Introduction

Congratulations on your purchase of a Checkline® LS-9-12000 Linear Stroboscope. It uses the principle of stroboscopic lighting to create an illusion of stopped motion, allowing detailed inspection of objects moving at high speeds.

**NOTE:** When using a stroboscope, it is important to remember that while objects may appear to become motionless, they are, in fact, still moving. Exercise proper care to prevent injury.

Please read this instruction manual thoroughly before operating your stroboscope. If you have any questions not answered by this manual, call your local supplier, or visit our web chat interface at [www.checkline.com](http://www.checkline.com) for full product support.

### 1.1 Package Contents

LS-9-12000 Stroboscope is shipped fully assembled in a metal enclosure. Your package should contain the following items:

- Stationary stroboscope
- Flash tube, factory installed
- Operating instruction
- Connector (1) for trigger input and supply

After unpacking, please examine your stroboscope for signs of mishandling during shipping. If damage has occurred, contact Electromatic before attempting to plug in the instrument. Notify your shipping carrier immediately for damage claim instructions.

## 2.0 Safety



LS-9-12000 stroboscopes operate at dangerously high voltages. Disconnect the unit from the power supply and wait two minutes for the capacitor to discharge before replacing the flash tube. Any service beyond flash tube replacement is not recommended.

- Do not look directly at the emitted light; it can damage your eyes. It may also trigger seizures in people with photosensitive epilepsy.
- Flash tubes are filled with high-pressure gas. When handling the flash tube always wear safety glasses and protective gloves.
- Do not allow inflammable liquids and water enter the stroboscope.
- When operating the stroboscope with the front screen facing upwards, the screen can heat up.
- The stroboscope must not be used in explosion hazard areas.

## 6.0 Flash Tube Replacement



### High Voltage!

Use only the manufacturer's original flashtubes.

Never touch the flashtube to your bare skin.

Only use the device with an undamaged front lens fitted.

1. Switch off the LS-9-12000 and remove the power supply plug. Wait two minutes for the capacitor to discharge before continuing.
2. Loosen the six (6) T10-TORX screws on the side of the unit with the yellow label.



**NOTE:** Do not open the screws on the other side of the unit. They are not T10-TORX type.

3. Slide front glass out laterally.
4. Using a clean cloth, carefully remove the old flashbulb.
5. Pick up new flashbulb with a clean cloth (free of dust and grease) and insert into the two retaining clips. Orient the tube so that the trigger wire can be easily attached to the terminal clamp screw. Ensure that the flashtube is correctly positioned in the socket.

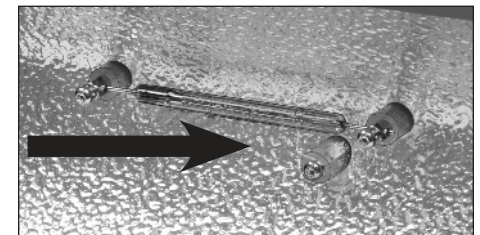
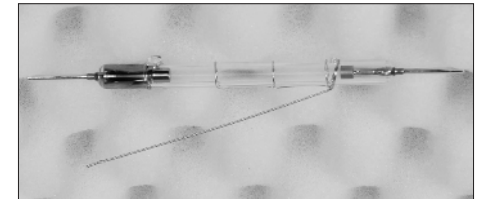

**IMPORTANT:** When the flashtube is correctly positioned, the extra length of wire will be closest to the **RIGHT** retaining clip and near the terminal clamp screw.

6. Re-insert the front screen and replace the screws.

**NOTE:** Never operate the stroboscope without a front screen or with a defective front screen.

## 5.0 Operation

1. Position the stationary stroboscope and connect the trigger input signal and supply voltage to the sockets as outlined in Section 4.0.
2. Switch the stroboscope on. The red LED will light, indicating that the unit is ready for use.
3. As soon as the trigger signal is applied, the strobe will start to flash with the trigger frequency.
4. If the flashing frequency coincides with the movement frequency, a stationary image will appear.





**NOTE:** A stationary image will not only appear with an identical flashing frequency, but also with multiples and fractions of the flashing frequency.

5. **Switching between sockets 1 and 2:**  
Use the rocker switch located between the two sockets to choose into which of the two sockets a trigger signal is to be fed.



Please make sure that an input signal is actually present at the socket selected.

6. **Setting the brightness:**  
Use the rotary knob marked with SHARP/BRIGHT and the / symbols to adjust the brightness to your needs.

Turn to the left, towards  (SHARP): Brightness is reduced.

Turn to right, towards  (BRIGHT): Brightness is increased.

## 3.0 Overview

*On Back (see below):* Sockets for trigger input and supply voltage, ON/OFF switch, LED power indicator

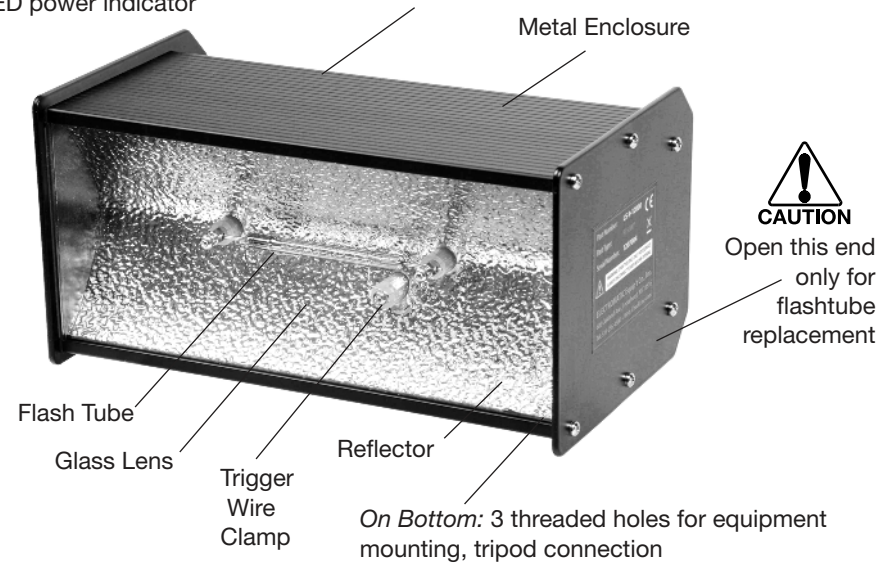

## Controls

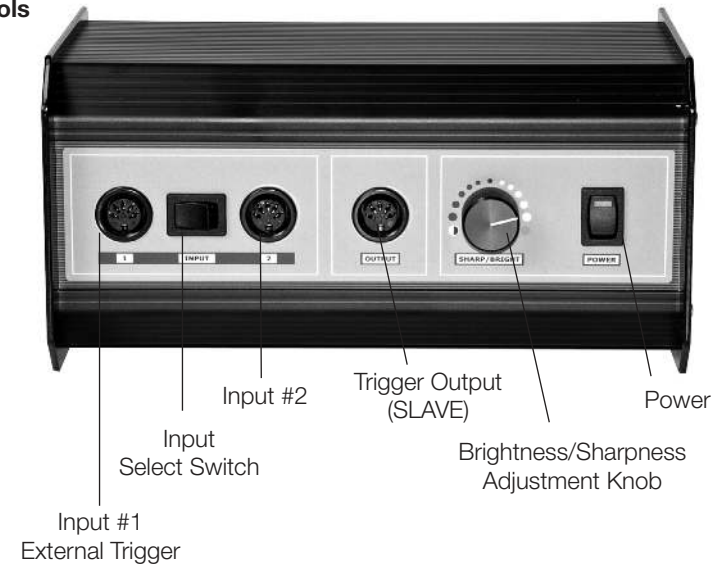

## 4.0 Assembly and Connection

Point the stroboscope at the object to be observed. On the bottom of the stroboscope are 3 threaded holes, which allow you to affix it to the equipment to be observed or a stand (available as an option):

- Center = 1 x 1/4" threaded hole
- Right and left, with a total distance of 60mm = 2 x M5 threaded holes



The stationary stroboscope has two identical assigned sockets (located on the back of the unit) for the combined input of trigger signal and supply voltage. The assignment of plug contacts is shown in **Figure 1**.

**CAUTION:** Please make the connections in accordance with the wiring diagram (Fig. 1). The trigger input is potential-free. The potential-free input is suitable for PNP and NPN signals. A matching plug for these input sockets is included with the stroboscope.

**RECOMMENDATION:** Use shielded cable to connect the trigger signal.

**CAUTION:** Do not trigger the stroboscope with signals above 12,500 FPM.

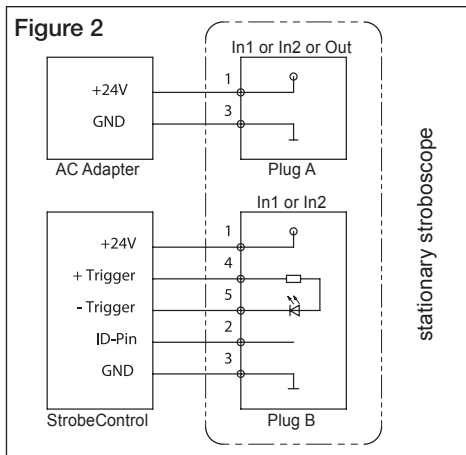
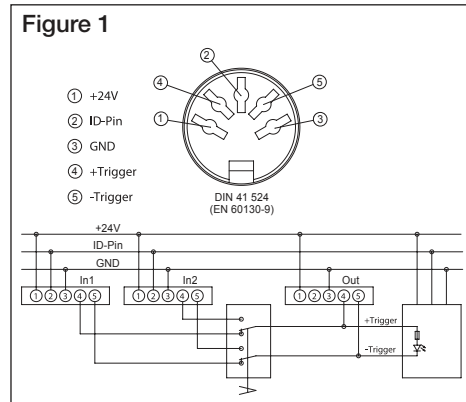

### 4.1 Typical connection examples

Please take connection examples from Figures 2 to 5. Note that you will need optional accessories for some of the examples (stationary stroboscope, AC Adapter, sensor, etc.)

**Figure 2** Trigger signal from optional stroboscope control unit, supply voltage from optional AC Adapter.

**FIG. 3** Trigger signal and supply voltage from external equipment.

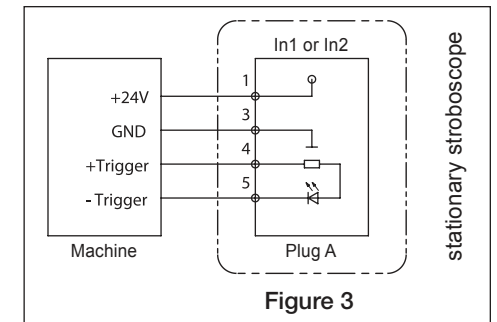

**FIG. 4** Trigger signal from external equipment, supply voltage from optional AC Adapter.

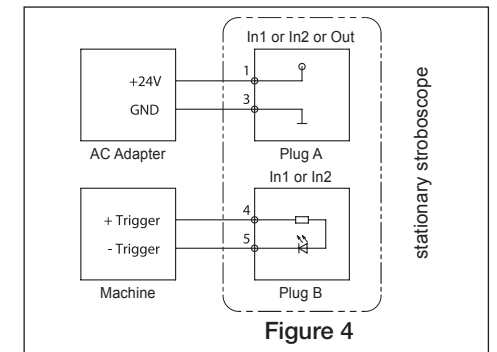

**FIG. 5** Trigger signal from optional sensor, supply voltage for strobe and sensor from optional AC Adapter.

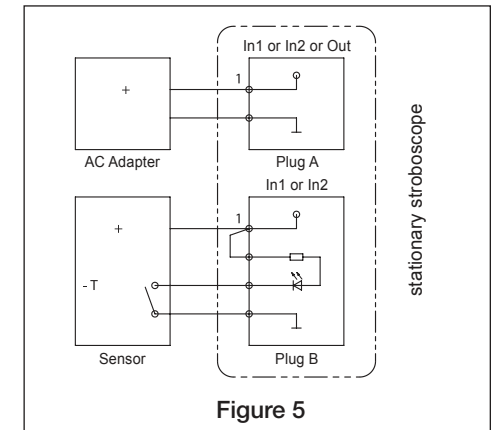

The voltage is either supplied by the strobe power supply unit (available as an option) or the equipment being observed.

**NOTE:** When using the LS-9-12000 stroboscope without a stroboscope control unit, the stroboscope flashes with the trigger signal of the connected equipment. This signal cannot be influenced without a stroboscope control unit.

---

---

---

## 8.0 Warranty

ELECTROMATIC Equipment Co., Inc. (ELECTROMATIC) warrants to the original purchaser that this product is of merchantable quality and confirms in kind and quality with the descriptions and specifications thereof. Product failure or malfunction arising out of any defect in workmanship or material in the product existing at the time of delivery thereof which manifests itself within one year from the sale of such product, shall be remedied by repair or replacement of such product, at ELECTROMATIC's option, except where unauthorized repair, disassembly, tampering, abuse or misapplication has taken place, as determined by ELECTROMATIC. All returns for warranty or non-warranty repairs and/or replacement must be authorized by ELECTROMATIC, in advance, with all repacking and shipping expenses to the address below to be borne by the purchaser.

THE FOREGOING WARRANTY IS IN LIEU OF ALL OTHER WARRANTIES, EXPRESSED OR IMPLIED, INCLUDING BUT NOT LIMITED TO, THE WARRANTY OF MERCHANTABILITY AND FITNESS FOR ANY PARTICULAR PURPOSE OR APPLICATION. ELECTROMATIC SHALL NOT BE RESPONSIBLE NOR LIABLE FOR ANY CONSEQUENTIAL DAMAGE, OF ANY KIND OR NATURE, RESULTING FROM THE USE OF SUPPLIED EQUIPMENT, WHETHER SUCH DAMAGE OCCURS OR IS DISCOVERED BEFORE, UPON OR AFTER REPLACEMENT OR REPAIR, AND WHETHER OR NOT SUCH DAMAGE IS CAUSED BY MANUFACTURER'S OR SUPPLIER'S NEGLIGENCE WITHIN ONE YEAR FROM INVOICE DATE.

Some State jurisdictions or States do not allow the exclusion or limitation of incidental or consequential damages, so the above limitation may not apply to you. The duration of any implied warranty, including, without limitation, fitness for any particular purpose and merchantability with respect to this product, is limited to the duration of the foregoing warranty. Some states do not allow limitations on how long an implied warranty lasts but, notwithstanding, this warranty, in the absence of such limitations, shall extend for one year from the date of invoice.

ELECTROMATIC Equipment Co., Inc.  
600 Oakland Ave. Cedarhurst, NY 11516—USA  
Tel: 1-800-645-4330/ Tel: 516-295-4300/ Fax: 516-295-4399

Every precaution has been taken in the preparation of this manual. Electromatic Equipment Co., Inc., assumes no responsibility for errors or omissions. Neither is any liability assumed for damages resulting from the use of information contained herein. Any brand or product names mentioned herein are used for identification purposes only, and are trademarks or registered trademarks of their respective holders.

---

**Stationary Stroboscope**

---

**Model LS-9-12000**

---



---

**Operating Manual**

---