



Series R53 smart sensors measure bi-directional (application and removal) bottle cap torque and other applications in the food and beverage, cosmetics, consumer products, and other industries. Adjustable posts accommodate a range of sample sizes, while alternative gripping attachments (high capacities only) accommodate unique shapes. Capacities available from 10 ozFin to 100 lbFin [7 to 1150 Ncm]. Compatible with Mark-10 model 5i and 3i indicators (sold separately) through unique Plug & Test™ technology.

Specifications

Accuracy:	±0.5% of full scale + indicator
Safe Overload:	MR53-10Z - MR53-50Z: 300% of full scale MR53-12 - MR53-100: 150% of full scale
Weight:	MR53-10Z - MR53-50Z: 2.2 lb [1.0 kg] MR53-12 - MR53-100: 5.4 lb [2.5 kg]

Optional Items

CT001	Flat jaws, pair, for MR53-12 - MR53-100
CT003	Adjustable jaws, pair, for MR53-12 - MR53-100



< Unique Plug & Test™ technology allows for interchangeable sensors to be used with a Mark-10 model 5i or 3i indicator. All calibration and configuration data is saved in the smart connector.



< The Plug & Test™ connector locks into the receptacle in the indicator when fully inserted. Dual buttons on the indicator housing release the connector for easy removal. Gold plated spring contacts ensure long lasting and reliable connection.



^ Low capacity Series R53 torque sensor is shown in a cosmetic packaging test.



^ Higher capacity Series R53 torque sensors accommodate larger sample sizes, as shown in the beverage closure application above.



^ Optional CT001 flat rubber jaws are ideal for square or odd shaped samples.



^ Optional CT003 adjustable jaws include 4 rubber-edged gripping arms per jaw. Arms may be independently repositioned in 45° increments to accommodate unique samples.

Dimensions in [mm]

MR53-10Z - MR53-50Z

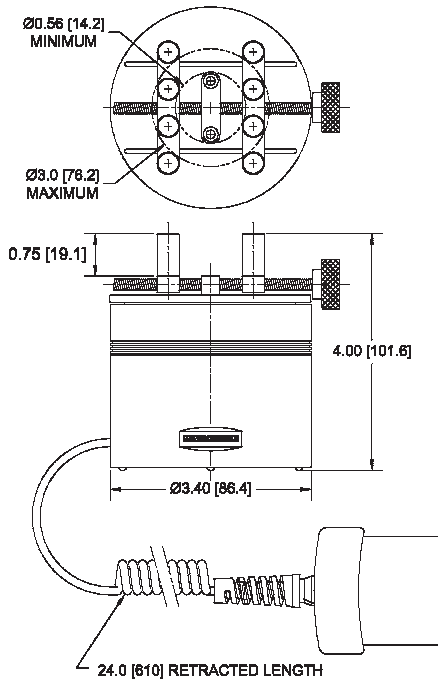

MR53-12 - MR53-100

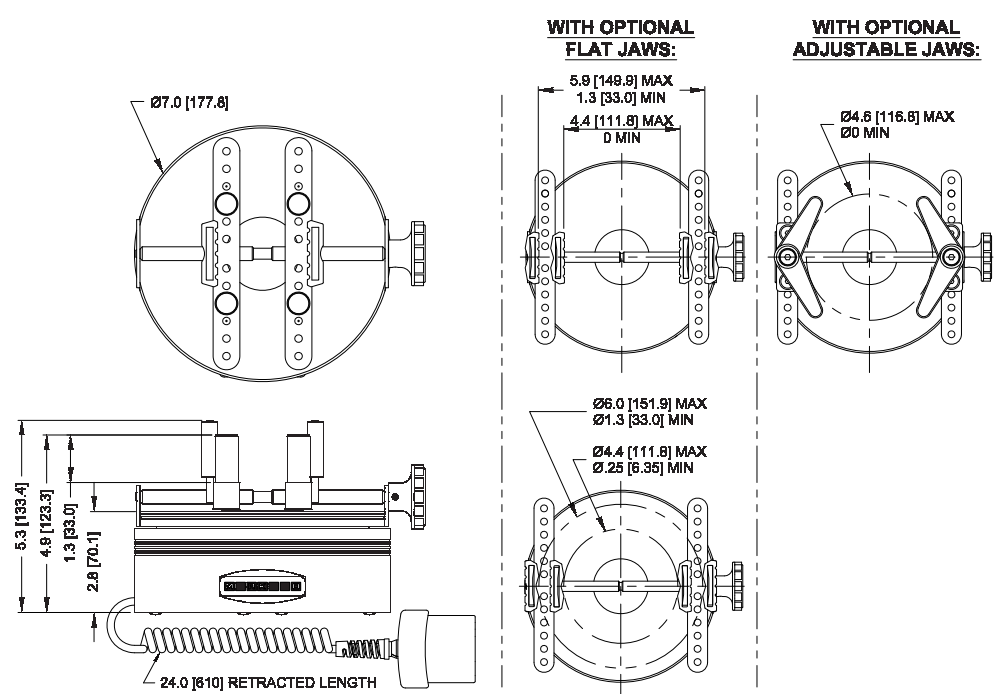

Capacity x Resolution

Model No.	Capacity x Resolution - with Model 5i indicator								Capacity x Resolution - with Model 3i indicator			
	ozFin	lbFin	lbFft	gFcm	kgFmm	Nmm	Ncm	Nm	ozFin	lbFin	kgFmm	Ncm
MR53-10Z	10 x 0.01	-	-	100 x 0.1	1 x 0.005	10 x 0.05	1 x 0.005	-	10 x 0.01	-	1 x 0.005	1 x 0.005
MR53-20Z	20 x 0.02	-	-	1400 x 1	14 x 0.01	140 x 0.1	14 x 0.01	-	20 x 0.02	-	14 x 0.01	14 x 0.01
MR53-50Z	50 x 0.05	-	-	3600 x 5	36 x 0.05	360 x 0.5	36 x 0.05	-	50 x 0.05	-	36 x 0.05	36 x 0.05
MR53-12	-	12 x 0.01	1 x 0.001	-	140 x 0.1	-	135 x 0.1	1.35 x 0.001	-	12 x 0.01	140 x 0.1	135 x 0.1
MR53-50	-	50 x 0.05	4 x 0.005	-	360 x 0.5	-	360 x 0.5	36 x 0.005	-	50 x 0.05	360 x 0.5	360 x 0.5
MR53-100	-	100 x 0.1	8 x 0.01	-	1150 x 1	-	1150 x 1	11.5 x 0.01	-	100 x 0.1	1150 x 1	1150 x 1