

32-1136



Series R51 smart sensors measure bi-directional torque for numerous applications across virtually all industries. Interchangeable Jacobs chucks and bit holder add flexibility for a variety of applications. The sensors can be used as hand held devices or mounted to a test stand. Superb overload protection adds peace of mind. Capacities available from 10 ozFin to 100 lbFin [7 to 1150 Ncm]. Compatible with Mark-10 model 5i and 3i indicators (sold separately) through unique Plug & Test™ technology.

Specifications

Accuracy:	±0.2% of full scale + indicator
Chuck opening range:	G1016-1: 0.028 - 0.25 in [0.7 - 6.3 mm] G1016-2: 0.062 - 0.375 in [1.6 - 9.5 mm] G1016-3: 0.078 - 0.5 in [2.0 - 12.7 mm] G1017: 0.25 in [6.3 mm] hex
Safe Overload:	MR51-10Z - MR51-50Z: 300% of full scale MR51-12 - MR51-100: 150% of full scale
Weight:	From 1.4 lb [0.6 kg]

Dimensions in [mm]

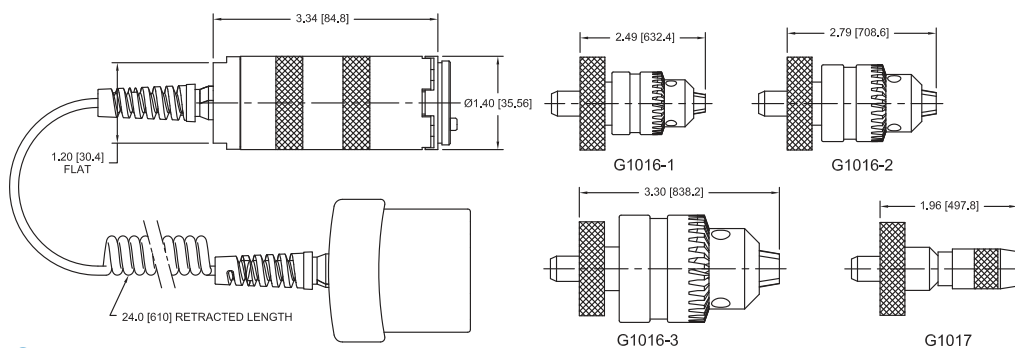

Capacity x Resolution

Model No.	Capacity x Resolution - with Model 5i indicator								Capacity x Resolution - with Model 3i indicator			
	ozFin	lbFin	lbFft	gFcm	kgFmm	Nmm	Ncm	Nm	ozFin	lbFin	kgFmm	Ncm
MR51-10Z	10 x 0.005	-	-	700 x 0.5	7 x 0.005	70 x 0.05	7 x 0.005	-	10 x 0.01	-	7 x 0.005	70 x 0.05
MR51-20Z	20 x 0.01	-	-	1400 x 1	14 x 0.01	140 x 0.1	14 x 0.01	-	20 x 0.02	-	14 x 0.01	14 x 0.01
MR51-50Z	-	-	-	5000 x 0.5	50 x 0.01	500 x 0.5	50 x 0.01	-	50 x 0.05	-	50 x 0.05	50 x 0.05
MR51-12	-	12 x 0.005	1 x 0.0005	-	140 x 0.1	-	135 x 0.1	1.35 x 0.001	-	12 x 0.01	140 x 0.1	135 x 0.1
MR51-50	-	50 x 0.005	4 x 0.0005	-	500 x 0.5	-	510 x 0.5	5.1 x 0.005	-	50 x 0.05	500 x 0.5	510 x 0.5
MR51-100	-	100 x 0.05	8 x 0.005	-	1150 x 0.5	-	1150 x 0.5	11.5 x 0.005	-	100 x 0.1	1150 x 1	1150 x 1



< Unique Plug & Test™ technology allows for interchangeable sensors to be used with a Mark-10 model 5i or 3i indicator. All calibration and configuration data is saved in the smart connector.



< The Plug & Test™ connector locks into the receptacle in the indicator when fully inserted. Dual buttons on the indicator housing release the connector for easy removal. Gold plated spring contacts ensure long lasting and reliable connection.



^ A Series R51 torque sensor is shown mounted to a model TSTM motorized torque test stand using optional AC1015 mounting kit.



^ Series R51 feature unique interchangeability with three chuck attachment sizes as well as a bit holder. The attachment is mated to the main sensor body with a pin, while a threaded ring holds the attachment in place.

Optional Items

G1016-1	Jacobs chuck for R51. 0.028 - 0.25 in
G1016-2 *	Jacobs chuck for R51. 0.062 - 0.375 in
G1016-3 *	Jacobs chuck for R51. 0.078 - 0.5 in
G1017	Bit holder for R51. 0.25 in
AC1015	Mounting kit. R51 to torque test stand

* Due to the increased possibility of overload, these attachments are recommended for use only with an MR51-12 or higher capacity model.