

Display Unit

SC Series

Model SC-PM  
SC-PMD

# CHECKLINE®

MADE TO MEASURE

## Instruction Manual

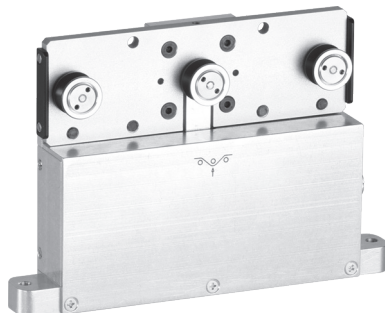
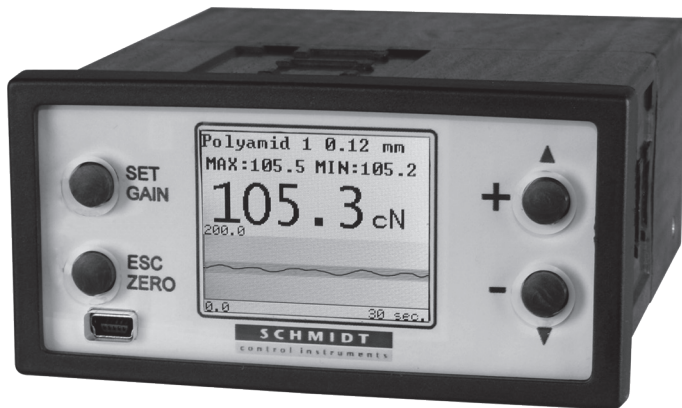

# Contents

<b>1</b>	<b>Warranty and liability</b>	<b>3</b>
1.1	Notices within the instruction manual	3
1.2	Responsibilities of the operating company	3
1.3	Responsibilities of the personnel	3
1.4	Informal safety measures	4
1.5	Training of the personnel	4
1.6	Intended use	4
1.7	Dangers in handling the device	4
1.8	Copyright	4
1.9	Declaration of conformity, RoHs II and WEEE registration	4
<b>2</b>	<b>General information</b>	<b>5</b>
2.1	Specifications	5
2.2	Dimensions of the SC-PM	5
2.3	Pin assignments of connectors and cable	6
2.4	Connecting the SC-PM	6
2.4.1	Connecting the SC-PM to USB or CAN-Bus	7
2.4.2	Connecting one SC-PM with the RS-422 interface	7
2.4.3	Connecting multiple SC-PM with the RS-422 interface	8
2.5	Delivery includes	9
2.5.1	Optional accessories	9
2.6	Unpacking	9
<b>3</b>	<b>Operation</b>	<b>10</b>
3.1	Operating elements	10
3.2	Initial setup	12
3.2.1	Switch-on	12
3.2.2	Switch-off	12
3.3	Instrument settings	12
3.4	Operating procedure	15
3.4.1	Damping	15
3.4.2	Using the alarm function	16
3.4.3	Changing the settings	16
3.5	Sensor calibration	17
3.5.1	Zero and gain adjustment	18
<b>4</b>	<b>Interfaces</b>	<b>20</b>
4.1	Analog interface	20
4.1.1	Zero and gain adjustment of the analog interface	20
4.2	Digital interface	20
4.2.1	The »Tension Inspect 3« program	20
4.2.2	Windows terminal program	20
<b>5</b>	<b>Online sensor specifications</b>	<b>21</b>
5.1	TS, FS and MZ series	21
5.2	SF series	21
<b>6</b>	<b>Service and maintenance</b>	<b>22</b>
<b>7</b>	<b>Cleaning</b>	<b>22</b>
<b>8</b>	<b>Correspondence</b>	<b>22</b>
<b>9</b>	<b>Repairs</b>	<b>22</b>

## **1 Warranty and liability**

In principle, the supply of the device is subject to our “General Conditions of Sale and Delivery.” These have been provided to the operating company on conclusion of the contract, at the latest.

Warranty:

- SCHMIDT display units are warranted for 12 months.
- Parts subject to wear, electronic components and measuring springs are not covered by the warranty. No warranty or liability will be accepted for bodily injury or property damage resulting from one or several of the following causes:
  - Misuse or abuse of the device.
  - Improper mounting, commissioning, operation and maintenance of the device (e.g. verification interval).
  - Operation of the device if any safeguards are defective or if any safety and protection precautions are not properly installed or not operative.
  - Failure to comply with the notices in the instruction manual regarding transport, storage, mounting, commissioning, operation, maintenance and setup of the device.
  - Any unauthorized structural alteration of the device.
  - Insufficient inspection of device components that are subject to wear.
  - Opening the device or improper repair work.
  - Disasters caused by the effects of foreign objects or by force majeure.

### **1.1 Notices within the instruction manual**

The fundamental prerequisite for the safe handling of this device and its troublefree operation is the knowledge of the basic safety notices and safety instructions.

These instruction manual contain the most important notices for the safe operation of the device.

These instruction manual, in particular the safety notices, must be observed by any person who works with the device. In addition, the local valid rules and regulations for the prevention of accidents must be complied with.

The representations within the instruction manual are not true to scale.

The dimensions given are not binding.

General indications of direction, such as FRONT, REAR, RIGHT, LEFT apply when viewing the front of the device.

### **1.2 Responsibilities of the operating company**

In compliance with the EC Directive 89/655/EEC, the operating company agrees to only permit persons to work with the device who:

- are familiar with the basic regulations on industrial safety and accident prevention and who have been trained in handling the device.
- have read and understood the chapter on safety and the warning notices in these instruction manual and have confirmed this with their signatures.
- are examined regularly on their safe and conscientious working method.

### **1.3 Responsibilities of the personnel**

All persons who work with the device agree to perform the following duties before starting work:

- to observe the basic regulations on industrial safety and accident prevention.
- to read the chapter on safety and the warning notices in these instruction manual and to confirm with their signatures that they have understood them.

#### 1.4 Informal safety measures

The instruction manual must always be kept on hand where the device is operated. Apart from the instruction manual, the general and local valid regulations on accident prevention and environmental protection must be provided and complied with.

#### 1.5 Training of the personnel

Only trained and instructed personnel is permitted to work with the device. The responsibilities of the personnel must be clearly defined for mounting, commissioning, operation, setup, maintenance, and repair. Trainees may only work with the device under the supervision of experienced personnel.

#### 1.6 Intended use

The device is intended exclusively for displaying tension values measured by the online sensors from Hans Schmidt & Co GmbH. Any use with sensors from other manufacturers or any use exceeding this intention will be regarded as misuse.

Under no circumstances shall Hans Schmidt & Co GmbH be held liable for damage resulting from misuse.

The intended use also includes:

- Complying with all notices included in the instruction manual and observing all inspection and maintenance works.

#### 1.7 Dangers in handling the device

The device was designed according to the state of the art and the approved safety standards. Nevertheless, its use may cause serious or fatal injury to the user or third persons, and/or an impairment of the device or of other material assets.

The device may only be applied:

- For its intended use in a faultless condition with regard to the safety requirements.
- Malfunctions that could impair safety must be remedied immediately.
- Personal protective equipment must be used according to the EC Directive 89/686/EEC.



**The device must not be operated in potential explosive areas and must not come into contact with aggressive substances.**

#### 1.8 Copyright

The copyright on these instruction manual remains with the company Hans Schmidt & Co GmbH.

These instruction manual is intended for the operating company and its personnel only. They contain instructions and notices that may only be reproduced on the prior written permission of Hans Schmidt & Co GmbH and under indication of the complete reference data. Violations will be prosecuted.

#### 1.9 Declaration of conformity, RoHs II and WEEE registration

In compliance with the EU Directives 2014/30/EU and 2011/65/EU



**Hans Schmidt & Co GmbH is registered in compliance with the German Electrical and Electronic Equipment Act (ElektroG) under WEEE Reg. No. DE 48092317.**

## 2 General information

### 2.1 Specifications

<b>Digital display:</b>	Colour TFT 128 x 160
<b>Units of measure:</b>	cN, daN, g, kg or lb (selectable)
<b>Damping (<math>f_g</math>):</b>	9-step adjustable
<b>Signal processing:</b>	Digital
<b>Measuring frequency:</b>	USB: 1 kHz RS-422: 200 Hz
<b>Output signal:</b>	Analog signal: 0 - 10 V DC ( $R_{Load} \geq 5K \text{ Ohm}$ ) Update time 1 msec (1000 Hz) Current: 4 - 20 mA (optional; instead of 0 - 10 V DC)
<b>Alarm limits:</b>	High/Low (selectable), with output signal Open collector max. 30 V DC, 10 mA
<b>Digital output signal:</b>	USB, RS-422, CAN-Bus (optional)
<b>Calibration</b>	4 characteristic curves can be saved
<b>Signal input for sensor:</b>	SC-PM: 0 - 1 V SC-PMD: mV/V
<b>Voltage output for sensor:</b>	SC-PM: 12 V SC-PMD: 3.3 V
<b>Power supply:</b>	15 - 24 V DC
<b>Current consumption:</b>	0.14 A
<b>Temperature range:</b>	10 - 45° C
<b>Air humidity:</b>	85% RH, max.
<b>Housing:</b>	Plastic
<b>Dimensions:</b>	115 x 95 x 48 mm
<b>Required cutout:</b>	91.5 x 45 mm
<b>Weight, net (gross):</b>	Approx. 200 g (300 g)

### 2.2 Dimensions of the SC-PM

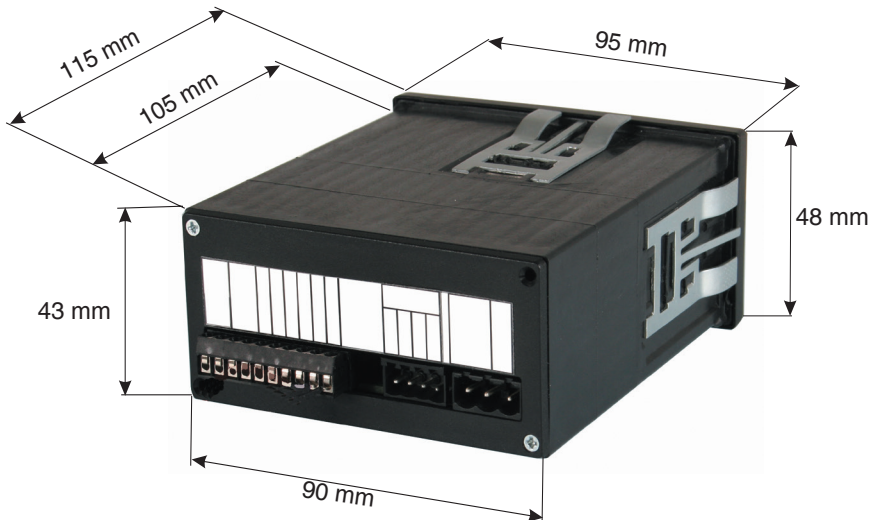

## 2.3 Pin assignments of connectors and cable

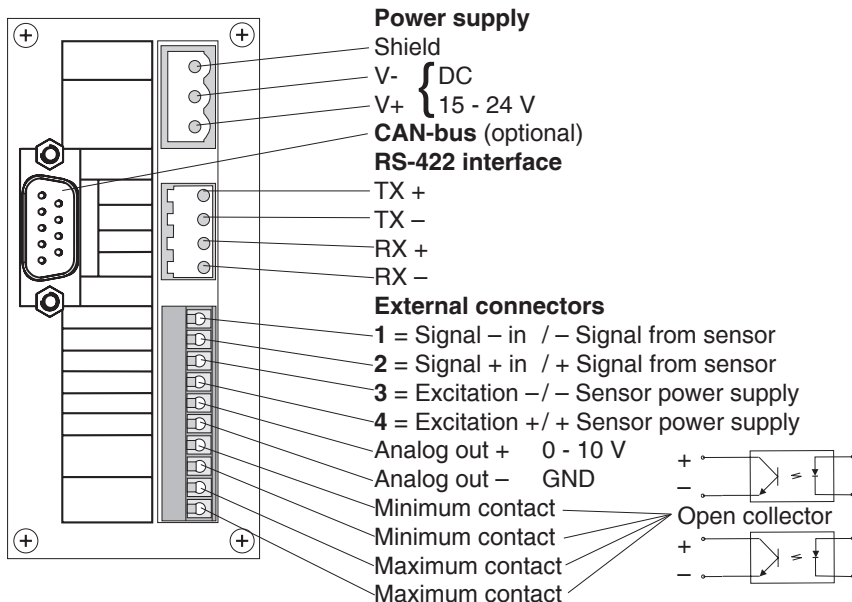

Series	TS Code A2/A3	TS Code A10	FS	MZ	SF
Signal - in [1]	white	green	blue	green	green
Signal + in [2]	grey	yellow	grey	yellow	white
Excitation - [3]	rose	brown	brown/black	brown	brown
Excitation + [4]	yellow	white	white	white	yellow

## 2.4 Connecting the SC-PM



The cable connecting the sensor with the display unit must be shielded. The shield of the connecting cable must be connected to the metal housing of the connecting plug.

Connect only sensors which comply with the specifications given in chapter 5.

To avoid random noise and malfunctions, make sure the cable connecting the SC-PM with the sensor does not run parallel to power lines or highly loaded signal lines, regardless of the type of voltage.



The requirements of the CE specification are only complied with if the SC-PM is equipped and operated with sensors and connecting cables supplied by Hans Schmidt & Co GmbH. Certification to the CE specification does not extend to, and shall be invalid for any other combination. Under no circumstances shall Hans Schmidt & Co GmbH be held liable for any damage resulting from the use of non-SCHMIDT sensors or cables.

## 2.4.1 Connecting the SC-PM to USB or CAN-Bus

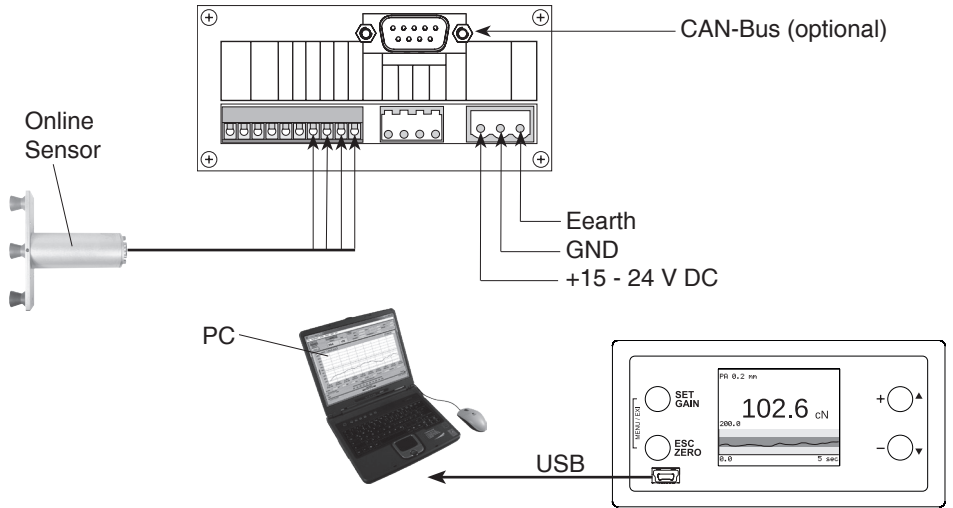

## 2.4.2 Connecting one SC-PM with the RS-422 interface



The two 2 x 240 W terminating resistors must always be installed in the terminal block of the SC-PM-422.

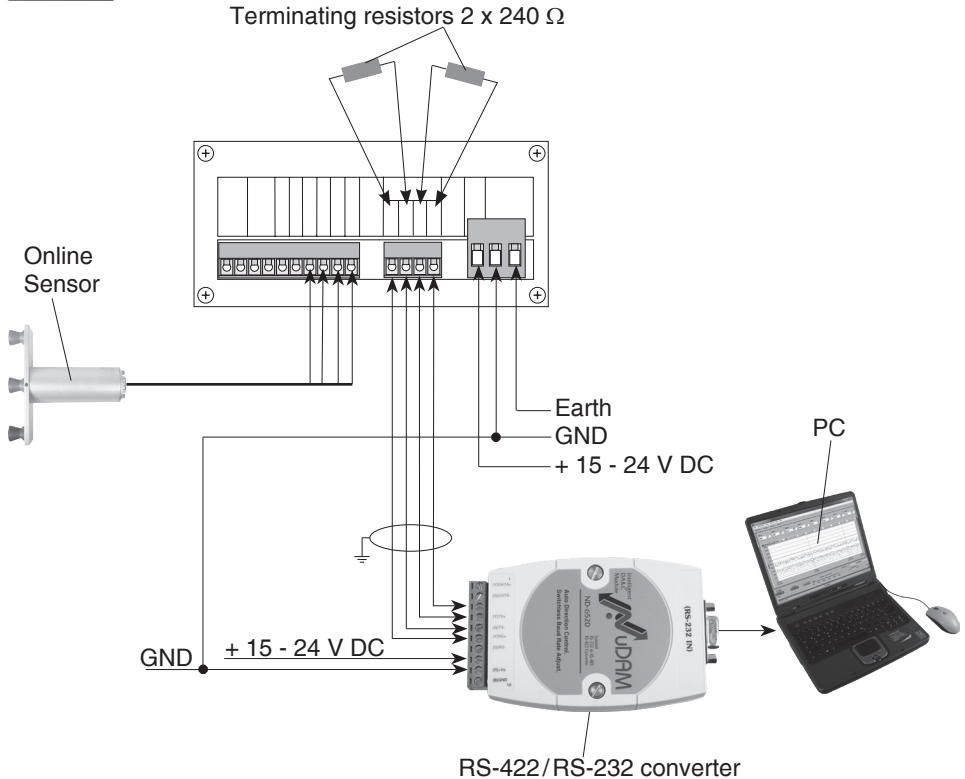

### 2.4.3 Connecting multiple SC-PM with the RS-422 interface



The two 2 x 240 W terminating resistors must always be installed in the terminal block of the SC-PM-422.

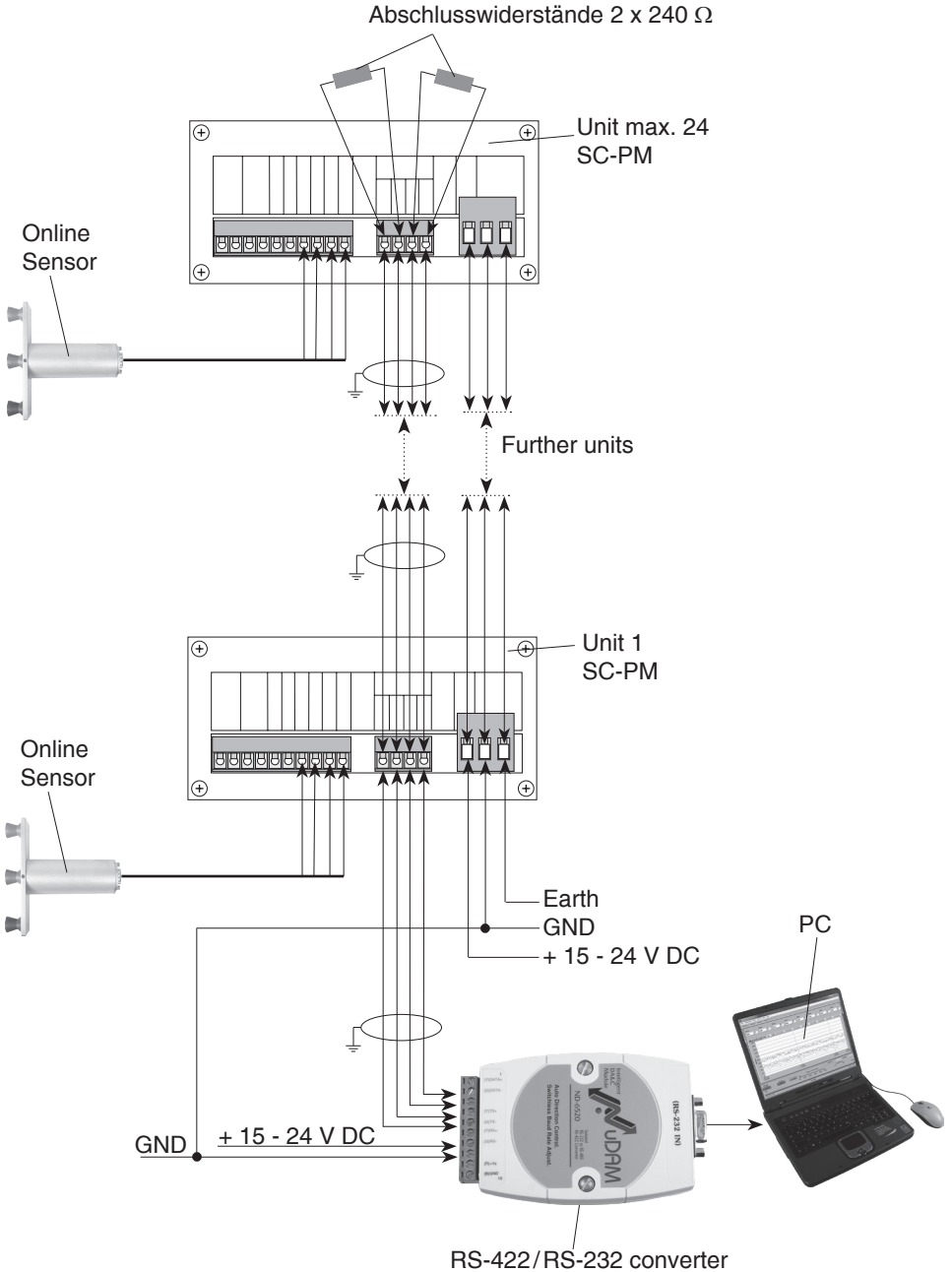



## 2.5 Delivery includes

- SC-PM display unit
- 3 alligator clips
- USB cable
- instruction manual

### 2.5.1 Optional accessories

Code **CAN**: CAN-bus interface

Code **A3**: Current output 4 - 20 mA (0 - 10 V analog signal not applicable)

All options must be factory fitted, re-fitting is only possible at the manufacturer's facility.

- EK0612 Connecting cable for TS sensor with 1 diode plug and open ends, length 3 m
- EK0614 Connecting cable for TS sensor with 1 diode plug and open ends, length 5 m
- EK0615 Connecting cable for TS sensor with 1 diode plug and open ends, length 10 m
- EK0620 Connecting cable for FS sensor with 1 sub-miniatur connector and open ends, length 2 m
- EK0621 Connecting cable for FS sensor with 1 sub-miniatur connector and open ends, length 5 m
- EK0622 Connecting cable for FS sensor with 1 sub-miniatur angle connector and open ends, length 2 m
- EBG800 Converter from RS-422 to RS-232
- EK0643 Connecting cable to connect the converter to PC, length 2 m
- SW-TI3 Software »Tension Inspect 3« for displaying and saving readings on a PC (Windows 7 and higher)

## 2.6 Unpacking

Unpack the display unit and inspect it for any shipping damage. Notices of defect must be announced immediately, in writing, at the latest within 7 days on receipt of the goods.

### 3 Operation

#### 3.1 Operating elements

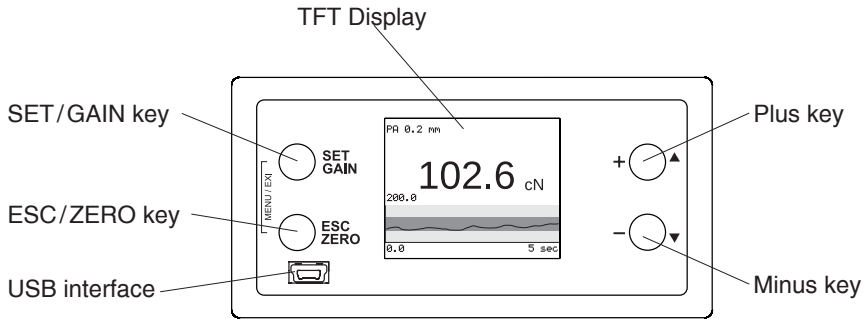

fig. 3.1a

#### Numeric display

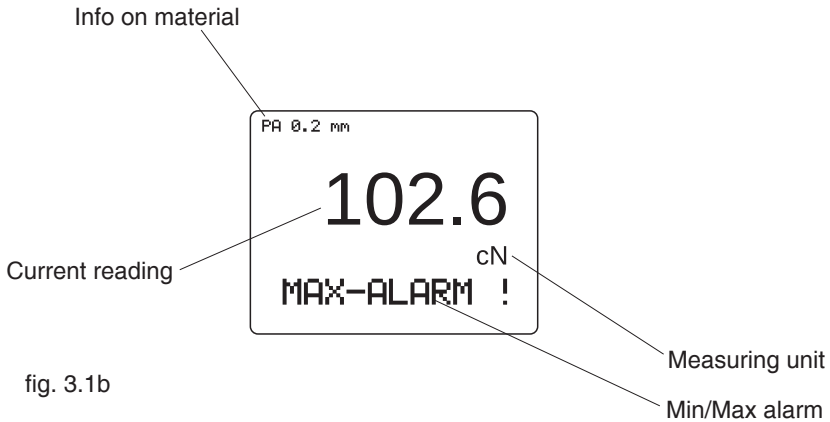
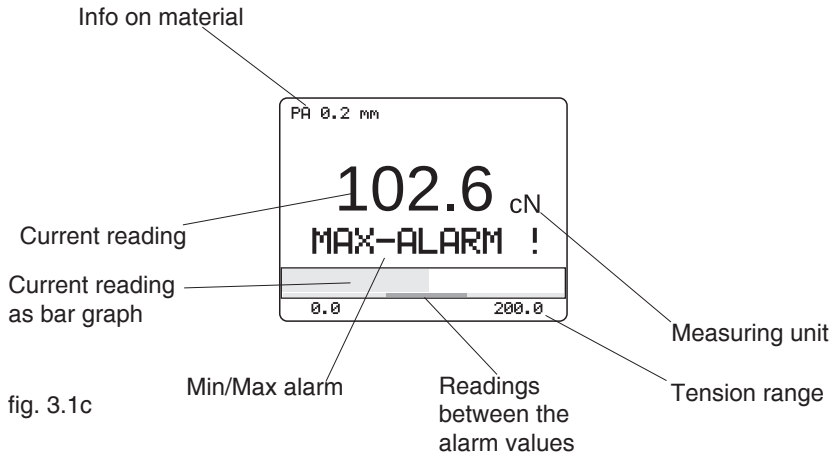

fig. 3.1b

### 3.1 Operating elements (cont.)

#### Display with bargraph



#### Graphic display

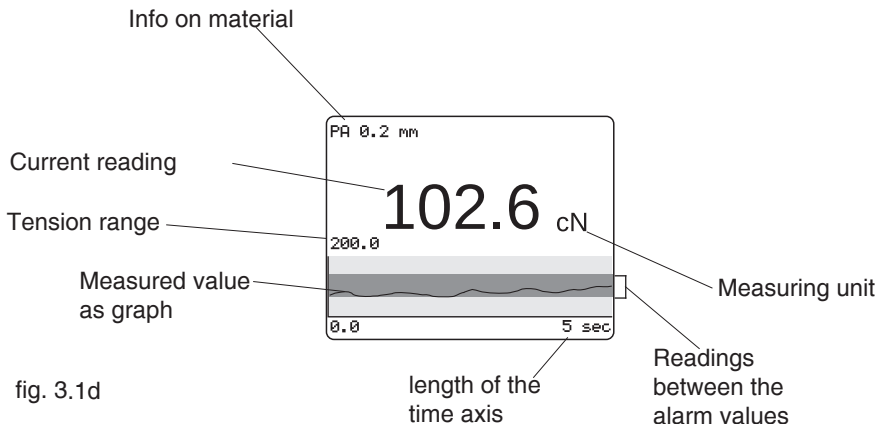

With the **+** and **-** button the X-axis can be scaled. The setting range is 2 to 60 sec.

The scaling can also be changed during the measurement, whereby values already displayed are deleted when the X-axis is changed

## 3.2 Initial setup

### Requirements:

- Install the sensor at the desired measuring location.
- Connect the external power supply.
- Connect the SC-PM to the supplied sensor with one of the optional available cables.



**In no event shall Hans Schmidt & Co GmbH take over any warranty coverage for, or shall be held liable for, any damage resulting from self-made cables.**

### 3.2.1 Switch-on

#### To switch on the SC-PM:

- Switch on the external power supply.













The TFT display successively shows:

the adjusted tension range, the adjusted channel ID (RS-422 interface), the CAN-Bus ID (only if the display is equipped with the optional interface), as well as software and hardware version (e. g. SW 1.0)



### 3.2.2 Switch-off

- Switch off the external power supply.

## 3.3 Instrument settings

- Press the  and  buttons simultaneously to access the main menu.
- The  and  buttons can be used to select the various menu items of the main menu, the submenus and the settings menus.
- Press the  button to open the selected menu; by pressing the  and  button you can close the main menu, while a submenu can be exited by pressing the  key.
- In menus with multi-digit fields (e.g. min Alarm) use the  buttons to move forward between the digits. With the  and  buttons the particular value can be set.
- Press the  button to save the settings and exit the settings menu or press the  to exit the current menu without saving.

### 3.3 Instrument settings (cont.)

Main Menu	Submenu	Settings Menu	Description
Material selection	Material	<b>[1]</b> , [2], [3], [4]	To select a material characteristic curve to be used for a measurement.
	Name	[character], [numbers], [special character]	To enter a name for the selected material characteristic.
	Damp (chapter 3.4.1)	[1] - [9]; <b>[4]</b>	To adjust the damping factor for the selected material characteristic
	Alarms	<b>[ON]</b> , [OFF]	To activate or deactivate the alarm function for the material characteristic. The alarm of a material characteristic curve is only active if it has also been activated in the Alarm menu item in the main menu.
	Low Limit	[0000] - [9999]	If the value falls below the set limit value, the display reads MIN-ALARM.
	High Limit	[0000] - [9999]	If the set limit value is exceeded, the display reads MAX-ALARM.
	Range	All possible tension ranges	The measuring range of the connected sensor must be selected.
	Unit	[cN], <b>[N]</b> , [daN], [kg], [lb], [g]	The unit of measurement of the connected sensor must be selected
Display (chapter 3.1)	—	[Numeric] [Bargraph] <b>[Graph]</b>	<ul style="list-style-type: none"> <li>Measured value displayed as number and alarm monitoring</li> <li>Measured value displayed as number, bar graph trend display and alarm monitoring</li> <li>Measured value displayed as graphical trend, measured value/limit values as graph</li> </ul> <p>By simultaneously pressing the  and  keys in the display mode, the display modes can be switched through.</p>
Time scale	—	<b>1</b> , 2, 5, 10, 30 und 60 seconds	To select the time period shown in the display (graphic display only).
Display damping (chapter 3.4.1)	—	[1] - [9]; <b>[4]</b>	For setting a different damping value than in the selected material characteristic curve. When changing the material characteristic curve, it will be changed automatically to the damping value that was set in the material characteristic curve.
Alarms (chapter 3.4.2)	—	<b>[ON]</b> , [OFF]	To activate or deactivate the alarm function.

Factory settings are illustrated bold

### 3.3 Instrument settings (cont.)

Main Menu	Submenu	Settings Menu	Description
System	Language	[English], [Geman], [Spanish], [french], [Portuguese]	Select between five user languages.
	Lock	[ON], [OFF]	If the lock is activated, no gain and zero adjustment can be performed.
	Background	[white], [black]	A white or black display background can be adjusted
	Analog Damp	[0] - [25]	For adjusting a damping factor for the analog interface.
	Alarm delay	[0] - [30]	Time period for which the measured value must be outside the limit values to trigger an alarm.
	Analog Adjustment	[-1500] - [+1500] [+100]	Chapter 4.1.1
	Faktery Reset	[No], [Yes]	Reset to the factory settings.
Interface	RS-422 adress	[0] - [24]; [1]	Chapter 3.4.3
	CAN-Bus ID	[Hexadecimal]	To set an address for the CAN bus.
	CAN Baudrate	[125K_550K] to [1000K_8M] [250K_1M]	It can be selected between 8 different baud rates.
	CAN Mode	[CAN 2.0A/b], [CAN FD] [CAN FD-BRS]	It can be selected between 3 types.
	CAN Frame	[Standard], [Extended]	For adjusting the CAN-bus frame type.
	Message Timer	[0] - [30]	For setting the time period in which data is sent.
	CAN Status	—	For readout of error messages.



**As the CAN bus interface is optional, the CAN bus setting options are not displayed for displays without CAN bus.**

### 3.4 Operating procedure



Have you read and understood the Operating Instructions, in particular chapter 1 “Warranty and liability”? You are not permitted to operate the device before doing so.

Before working with the device you must put on your personal protective clothing, if necessary. For example, eye protectors, gloves, etc.



The ID plate with the CE mark and the serial number as well as the calibration label (optional) and the SCHMIDT Quality Seal are provided on the surface of the instrument.

- Switch on the instrument as described in chapter 3.21.
- Instrument settings as described in chapter 3.3.
- Select a material characteristic curve (chapter 3.3) or generate a new adjustment (chapter 3.4)
- Allow approx. 10 minutes for thermal stabilization of the instrument.
- Thread the process material through the measuring and guide rollers, following the red material path symbol on the front of the sensor.

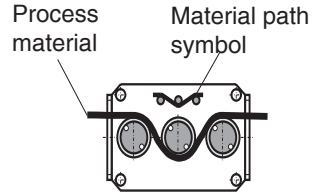

The measured tension can be read in the display.

#### 3.4.1 Damping

Feature to be used for tensions that vary strongly

In the “Damping” submenu, a damping factor can be selected for each material characteristic curve. In the “Display damping” menu, the damping factor of the currently selected material characteristic curve is displayed. This can be changed in the “Display damping” menu without changing the setting in the material characteristic curve. To use the damping factor assigned to the material characteristic curve again, this must be set in the “Display damping” menu or the material characteristic curve must be selected again.

The factory setting for the damping factor is 5. The average shown on the display is calculated as follows:

$$\frac{5 \text{ old measured values} + 4 \text{ new measured values}}{9}$$

Damping can be changed in 9 steps from 01 = low damping:

$$\frac{1 \text{ old measured value} + 8 \text{ new measured values}}{9}$$

to 9 = high damping:

$$\frac{8 \text{ old measured values} + 1 \text{ new measured value}}{9}$$

### 3.4.2 Using the alarm function

#### Requirements:

A min. and max. limit value must be set in the "Material selection" menu for the material characteristic curve with which a measurement is to be conducted. Furthermore, the alarm must be activated in the "Material selection" menu. In addition, the alarm must be activated in the "Alarm" menu.

### 3.4.3 Changing the settings

#### Channel selection

You can connect up to 24 display units by cable to the RS-422-to-RS-232 converter and on to a PC. The individual display units are distinguished by different channel numbers (chan), which can be assigned sequentially as shown in fig. 3.4.3a or in random order as shown in fig. 3.4.3b. If you connect more than one display unit, the lowest channel number (chan) assigned must always be 01, as shown in fig. 3.4.3a and fig. 3.4.3b. If you connect only one display unit, this unit must be assigned the channel number 00, as shown in fig. 3.4.3c.

fig. 3.4.3a

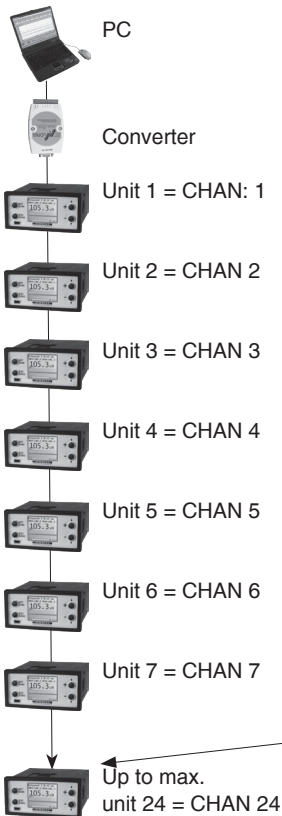

fig. 3.4.3b

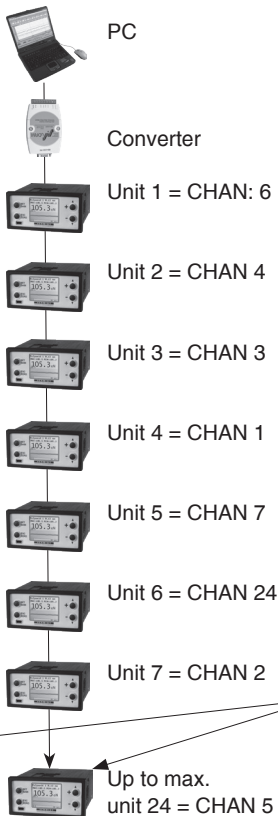
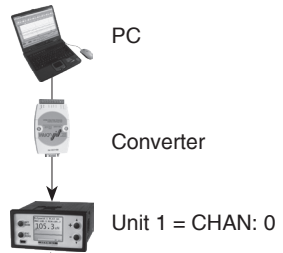



fig. 3.4.3c



  
**Always connect the terminating resistors to the physically last unit of the cable connection.**



### 3.5 Sensor calibration

All tension meters are calibrated with standard materials - such as polyamide monofilament (PA) - according to the SCHMIDT factory procedure; the material path is vertical. The corresponding diameter and material can be found in chapter 2 of the sensor. In the case of factory adjustment to the customer's sample, the procedure is the same. In this case, however, the adjustment to the SCHMIDT sample is omitted. Any difference in process material size and rigidity from the standard material may cause a deviation of the accuracy. In 95% of all industrial applications, the SCHMIDT calibration has been proven to provide the best results and is used for comparative purposes.

If required you can also operate the sensor with a material path other than vertical. Should the process material differ significantly from the SCHMIDT calibration material in size, rigidity or shape, we recommend special calibration using customer supplied material. If a different material path (e.g. horizontal) or special calibration using customer supplied material is required, you need to carry out static **zero** and **gain adjustment** as described in chapter 3.5.1.



**Since zero and gain adjustments are always performed statically, the readings may differ under dynamic load.**

### 3.5.1 Zero and gain adjustment

You can save up to three different calibrations.





**The instrument is factory-set to material characteristic curve 1. This is the factory calibration, which should not be overwritten.**

#### Requirements:

- Two weights, one corresponding to 10% and one to 90% of the selected tension range, must be provided. Pay attention to the selected unit of measure (cN or kg).
- Sensor installed at measuring location.
- Instrument switched on as described in chapter 3.2.1.
- Allow approx. 10 minutes for thermal stabilization of the instrument.
- The desired material characteristic is selected according to chapter 3.3

#### Zero adjustment:

- Thread the process material through the measuring and guide rollers, following the red material path symbol on the front of the sensor.
- Hang a weight that corresponds to e.g. 10% of the tension range (pay attention to the correct unit of measure) from the process material, vertically, as shown in fig. 3.4.1. (Always use a fresh portion of the material to be measured.)
- Press and hold the  key.
- Press the  or  key repeatedly until the tension value on the LCD is equal to the value of the suspended weight.  
For example: Sensor model TS1-200  
Weight 20 cN =

TFT display 

- Release the  key.

The set value is saved to the calibration curve after approx. 20 seconds and the instrument changes back to measuring mode.

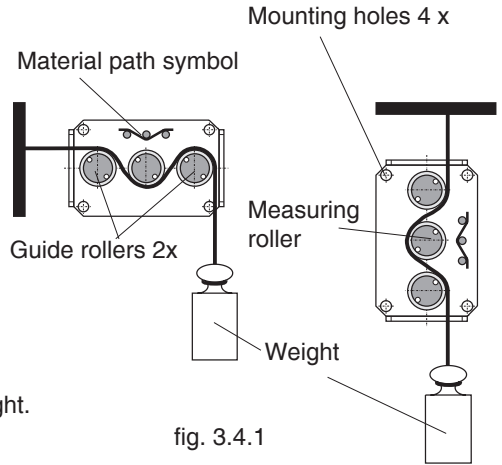

**The zero adjustment values are only saved permanently in the SC-PM memory after approx. 20 seconds. Therefore the unit must not separated directly from the power supply.**



### 3.5.1 Zero and gain adjustment (cont.)

#### Gain adjustment:

##### Requirement:

Zero adjustment carried out.

##### To carry out gain adjustment:

- Thread the process material through the measuring and guide rollers, following the red material path symbol on the front of the sensor.
- Hang a weight that corresponds to e.g. 90% of the tension range (pay attention to the correct unit of measure) from the process material, vertically, as shown in fig. 3.5.1. (Always use a fresh portion of the material to be measured.)
- Press and hold the  key.
- Press the  or  key repeatedly until the tension value on the LCD is equal to the value of the suspended weight.

For example: Sensor model TS1-200

Weight 180 cN = Display 

- Release the  key.  
The set value is saved to the calibration curve after approx. 20 seconds and the instrument changes back to measuring mode.



**The gain adjustment values are only saved permanently in the SC-PM memory after approx. 20 seconds. Therefore the unit must not separated directly from the power supply.**

- Check the adjustments with a fresh portion of the process material and repeat the procedure if necessary.

## 4 Interfaces

### 4.1 Analog interface

The analog interface is provided for customer signal processing or for connecting a line recorder which conforms to the current industrial standard.

Please refer to chapter 2.1 for the specifications.



**CAUTION - The analog interface must be calibrated only by qualified electrical personnel.**





#### 4.1.1 Zero and gain adjustment of the analog interface

##### Requirements

- Connect a volt meter to the analog interface.
- Switch on the instrument as described in chapter 3.2.1.
- Allow approx. 10 minutes for thermal stabilization of the instrument.
- Thread the process material through the measuring and guide rollers.

##### Zero adjustment:

- Select the "Analog adjustment" menu item (chapter 3.1)
- Press the  or  key repeatedly until the display of the volt meter connected to the analog interface reads 10.0 volts.  
Check the setting and repeat the procedure if necessary.
- Save the adjusted values and exit the menu by pressing 

### 4.2 Digital interface

#### 4.2.1 The »Tension Inspect 3« program

The Tension »Inspect Software 3« from SCHMIDT is described in a separate user manual.

#### 4.2.2 Windows terminal program

The measured values can be transmitted to a personal computer.

You can connect the computer to the SC-PM by using the RS-422/RS-232 converter which is available as an accessory.

##### Requirement:

A communication program, such as Terminal or HyperTerminal (provided on MS Windows Version 3.0 or later), must be installed and configured on the computer.

## 5 Online sensor specifications

### 5.1 TS, FS and MZ series

TS series (models TS1, TSP, TSR, TSH, TSL, TSF, TSF1, TSW, TSB1, TSB2)

FS series (models FS1, FSP, FSR, FSH, FSL, FSW, FSB1)

MZ series (models MAZD, MBZD, MAZF, MBZF, MBZB, MZ1, MZH, MZB1)

Calibration: According to SCHMIDT factory procedure

Accuracy: For 10% to 100% of range:

TS:  $\pm 1$  % full scale

FS:  $\pm 1.5$  % full scale

MZ:  $\pm 2$  % full scale

MZ1, MZH, MZB1: 1.5 % full scale

Remainder of range and

Other calibration material:  $\pm 3$  % full scale or better

Overload protection: 100 % of range

Measuring principle: Strain gauge bridge

Measuring roller deflection: 0.5 mm max.

Signal processing: Analog

Output signal: 0 - 1 V DC (standard)

Damping ( $f_d$ ): Standard: 30 Hz (other values on request)

Temperature coefficient: Gain: less than  $\pm 0.05\%$  full scale/ $^{\circ}\text{C}$

Temperature range: 10 - 45  $^{\circ}\text{C}$

Air humidity: 85 % RH, max.

Power supply: Standard: + 15 to + 24 V DC (21 mA, regulated)

Further technical details are provided in the instruction manual for the sensors.

### 5.2 SF series

Models SFZ and SFD

Accuracy: 0.5 % full scale

Max. applied force: 160 % full scale, overload protection afterwards

Overload protection: SFZ: 10 times of nominal load, max. 3200 N

SFD: 10 times of nominal load, max. 2000 N

Lateral force at the axis: Max. 100 % nominal load

Measuring principle: Strain gauge bridge

Output signal: SFZ: 5 - 20 N: 1 mV/V, 50 N and higher: 1.5 mV/V

SFD: 1 mV/V

Temperature range: 10 - 70  $^{\circ}\text{C}$

Power supply: 10 V DC

Further technical details are provided in the instruction manual for the sensors.

## 6 Service and maintenance

The display unit is maintenance-free.

## 7 Cleaning

For cleaning the unit, do not use any



### **AGGRESSIVE SOLVENTS**

such as trichloroethylene or similar chemicals.



### **NO WARRANTY OR LIABILITY**

shall be accepted for damage resulting from improper cleaning.

## 8 Correspondence

Should you have any questions regarding the instrument or Operating Instructions, or their use, please indicate above all the following details which are given on the ID plate:

- 1.) Model
- 2.) Serial number

## 9 Repairs

### **Shipping instructions:**

We kindly ask for return free of charge for us, if possible by airmail parcel. All occurring charges, if any (such as freight, customs clearance, duty etc.), will be billed to customer.

For return from foreign countries, we ask you to include a proforma invoice with a low value for customs clearance only, e.g. 50 Euro, each and to advise the shipment in advance by fax or eMail.



**To avoid unnecessary follow-up questions, and the resulting loss of time or possible misunderstandings, please return the unit with a detailed fault description to our service department. Please indicate in your order whether you require an Inspection Certificate 3.1 according to DIN EN 10204.**

Notizen:

---

---















---

---

---

# CHECKLINE®

MADE TO MEASURE

-  Tension Meter
-  Force Gauge
-  Torque Meter
-  Tachometer
-  Speed- and Lengthmeter
-  Electronic Lengthmeter
-  Stroboscope
-  Screen Printing Tension Meter
-  Thickness Gauge
-  Yarn Package Durometer and Shore Durometer
-  Sample Cutter
-  Balance
-  Moisture Meter
-  Leak Tester

**CHECKLINE®**  
MADE TO MEASURE