NOTES

TABLE OF CONTENTS

1.0	Calibration curves	2
2.0	Design of the device	2
3.0	Measuring procedure	3
4.0	Direction of plug in	4
5.0	Menu level overview	5
6.0	Keypad symbols	6
7.0	List of calibration curves	6
8.0	Activation of the "super user" function	6
9.0	Changing the User level	7
10.0	Measuring value out of range	7
11.0	Transfer saved data to the PC	8
12.0	Print saved data	9
13.0	Changing batteries	10
14.0	Determination of the material reference moisture	10
15.0	Exemption from liability	11
16.0	Technical data	11
17.0	Most common reasons for miss readings	12
18.0	Warranty	13

1.0 CALIBRATION CURVES

Calibration curves	Declaration	Compressed density	Measuring range limit
straw round bal.	Straw round bales	> 130kg/m ³	8,5% - 30%
straw bales	Straw bales	100 up to 130kg/m ³	8,5% - 30%
straw loose	Straw		8,5% - 30%
hay round bales	hay round bales	> 130kg/m ³	8,5% - 25%
hay bales	hay bales	100 up to 130kg/m ³	8,5% - 25%
hay loose	Hay		8,5% - 25%
cellulose	Insulating material	38 – 65kg/m ³	10,0% - 35%
Digit	Special products		0,0% - 100%
Test block	<i>! Only for testing the device with the test block !</i>		

Free Calibration curves:

There are another 2 empty calibration curves stored in the measurement device. These can be used to add some curves of special materials.





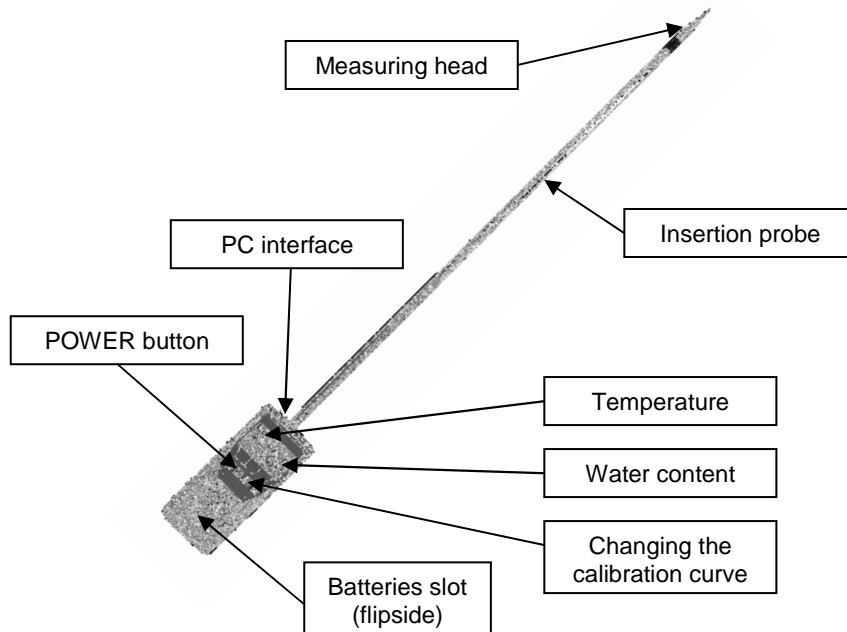



NOTES

2.0 DESIGN OF THE DEVICE



NOTES

3.0 MEASURING PROCEDURE

1. For a correct measurement please ensure that the device has the same temperature than the material you want to measure ($\pm 3^{\circ}\text{C}$). For that reason, let your MCT-HS-PRO adjust to the surrounding temperature of the material for at least half an hour before measuring (protect from direct sunlight!).
- 2.) Switch on the device: Press the  key for 3 seconds.
- 3.) To change the calibration curve, please press the  or  key.
- 4.) Plug the probe into the material. The display shows the water content immediately.
- 5.) Pay attention to the direction of plugging in! (pay attention to the following page!)
- 6.) To save the results in the save menu press the  ( button). The storage was successful when the number in front of the  symbol increased. To reach the store menu please press () until the  appears.

ATTENTION! Risk of injury!

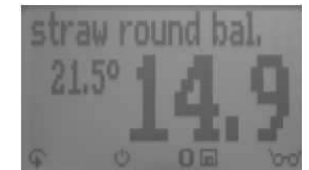
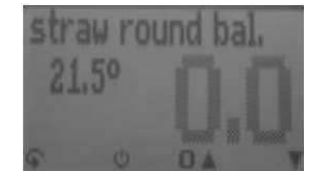

4.0 DIRECTION OF PLUG IN

Insert the device into the bale like shown in the picture below. Any other direction of plugging lead to a significant deviation of the measuring results. Pull the unit straight out again. Any mechanical damage due to mishandling is no case of guarantee.

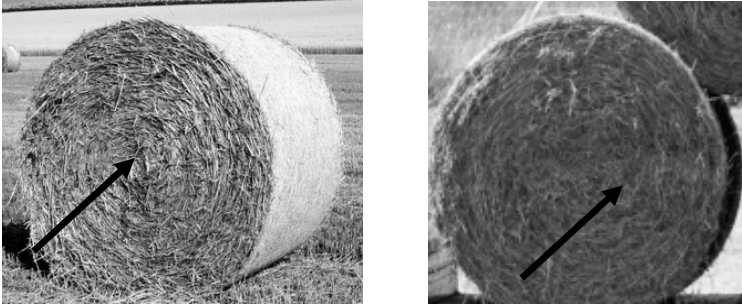

Round bales have to be measured on the face side. Measurements at the bearing surface lead to miss readings.



Rectangle bales have to be measured on the face side. Measurements at the other side can lead to miss readings.

Measuring of loose material

Fix the delivered compression plate like it is shown in the pictures. Switch to the right calibration curve ("straw loose" or "hay loose") and stab in the material. It is very important that there is a good contact between the material and the plate. These curves should be used before you press the material to bales.

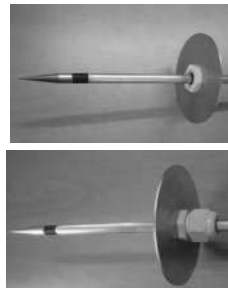

18.0 WARRANTY

Electromatic Equipment Co., Inc. (Electromatic) warrants to the original purchaser that this product is of merchantable quality and confirms in kind and quality with the descriptions and specifications thereof. Product failure or malfunction arising out of any defect in workmanship or material in the product existing at the time of delivery thereof which manifests itself within one year from the sale of such product, shall be remedied by repair or replacement of such product, at Electromatic's option, except where unauthorized repair, disassembly, tampering, abuse or misapplication has taken place, as determined by Electromatic. All returns for warranty or non-warranty repairs and/or replacement must be authorized by Electromatic, in advance, with all repacking and shipping expenses to the address below to be borne by the purchaser.

THE FOREGOING WARRANTY'S IN LIEU OF ALL OTHER WARRANTY'S, EXPRESSED OR IMPLIED, INCLUDING BUT NOT LIMITED TO, THE WARRANTY OF MERCHANTABILITY AND FITNESS FOR ANY PARTICULAR PURPOSE OR APPLICATION. ELECTROMATIC SHALL NOT BE RESPONSIBLE NOR LIABLE FOR ANY CONSEQUENTIAL DAMAGE, OF ANY KIND OR NATURE, RESULTING FROM THE USE OF SUPPLIED EQUIPMENT, WHETHER SUCH DAMAGE OCCURS OR IS DISCOVERED BEFORE, UPON OR AFTER REPLACEMENT OR REPAIR, AND WHETHER OR NOT SUCH DAMAGE IS CAUSED BY MANUFACTURER'S OR SUPPLIER'S NEGLIGENCE WITHIN ONE YEAR FROM INVOICE DATE.

Some State jurisdictions or States do not allow the exclusion or limitation of incidental or consequential damages, so the above limitation may not apply to you. The duration of any implied warranty, including, without limitation, fitness for any particular purpose and merchantability with respect to this product, is limited to the duration of the foregoing warranty. Some states do not allow limitations on how long an implied warranty lasts but, notwithstanding, this warranty, in the absence of such limitations, shall extend for one year from the date of invoice.

Electromatic Equipment Co., Inc.
600 Oakland Ave. Cedarhurst, NY 11516 - USA
Tel: 1-800-645-7330 / Tel: 516-295-4300 / Fax: 516-295-4399

Every precaution has been taken in the preparation of this manual. Electromatic assumes no responsibility for errors or omissions. Neither is any liability assumed for damages resulting from the use of information contained herein. Any brand or product names mentioned herein are used for identification purposes only, and are trademarks or registered trademarks of their respective holders.

17.0 MOST COMMON REASONS FOR MISS READINGS

- Product temperature out of application range**
 Material below 0°C resp. above +40°C may cause faulty measurements. The storage of cold material in a warm storage area usually creates condensed water which may lead to major measuring errors.
- Discrepancy in temperature between device and material**
 Please ensure that the device and the material under test are being stored at the same temperature (+/- 3°C) before measuring. Protect your measuring device from direct sunlight for a reasonable time period before taking a measurement. A high temperature difference has a negative effect on the stability of the measurement results.
- Wrong calibration curve**
 Double check the correct selection of the calibration curve before measuring.
- Wet or mouldy material**
- Frozen measuring material or material containing snow**
 This leads to a major decrease in accuracy.
- Direction of plugging in**
 The Direction of plugging has a great influence on the accuracy. Necessarily follow the instructions according to the beginning of the manual!
- Compressed density outside the application range**
 If the compressed density differs from that specified, there may be deviations!
- Moving the measuring head after the plug in leads to miss readings!**
- Water film at the measuring head**
 After measuring wet material a water film can arise on the sensor head. This could lead to a too high result in the following measurements. After measuring wet material clean both black plastic parts of the measuring head accurately with a dry cloth.





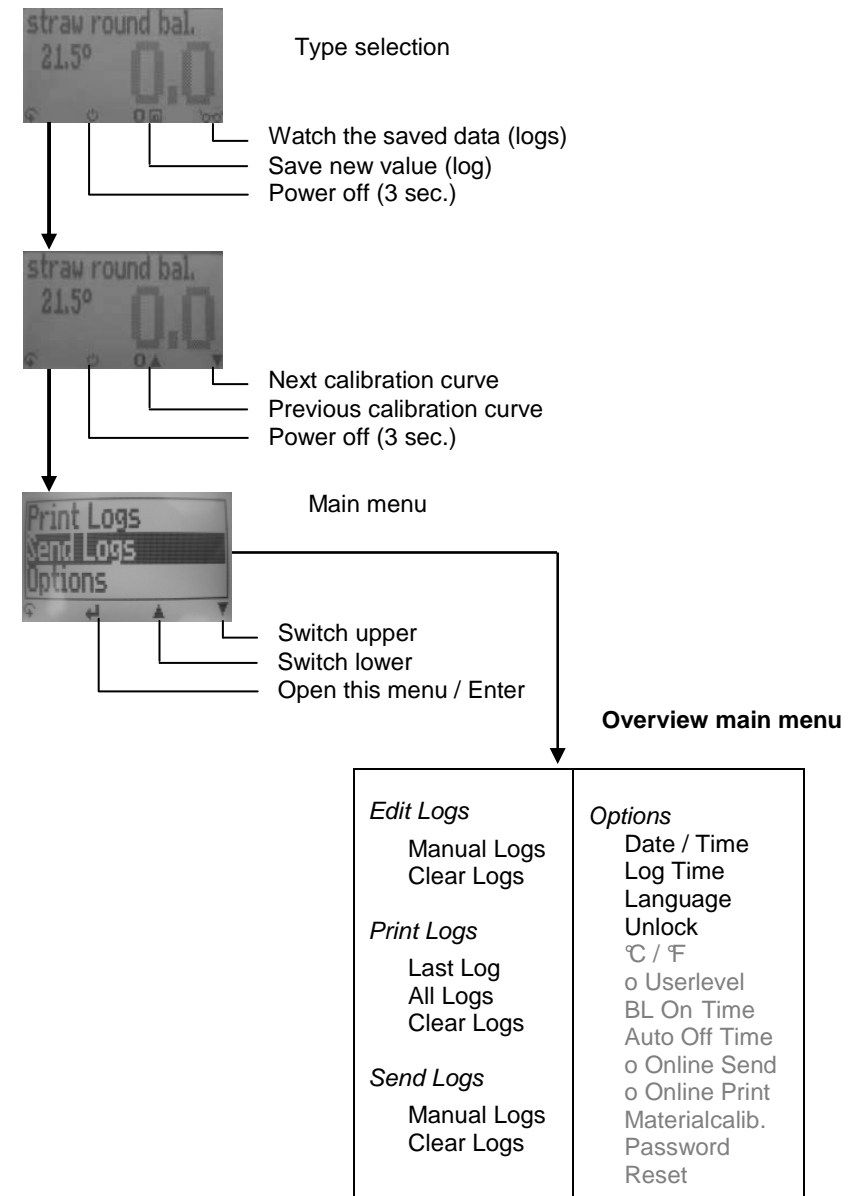

ATTENTION: Risk of injury by measuring head!
Keep away from children younger than 16 years!

5.0 MENU LEVEL OVERVIEW















6.0 KEYPAD SYMBOLS

Measuring window:

	Rolling Menu
	Power ON / OFF
	Switch upper
	Switch lower
	Save
	Hold
	Watch the saved data

Menu:

	Enter
	Switch upper
	Switch lower
	Exit
	Enter numbers
	Enter letters
	Next or right
	Left
	Yes
	No
	Shift
	OK

7.0 LIST OF CALIBRATION CURVES

Pressing the ▲ or ▼ key in the measuring window for at least 3 seconds and a list with all available sorts will appear. Select your sort by pressing ▲ or ▼ and confirm it with the ↵ key. The measurement will continue automatically.

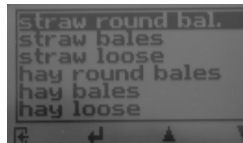

8.0 ACTIVATION OF THE “SUPER USER” FUNCTION

2 times ⌘ - *Options* – Unlock

Enter the 4-digit password by using the ▲ button (standard is the 4-digit serial number) and confirm by pressing the ↵ button.

15.0 EXEMPTION FROM LIABILITY

For miss-readings and wrong measurements and of this resulting damage we refuse any liability.

This is a device for quick determination of moisture. The moisture depends on multiple conditions and multiple materials. Therefore we recommend a plausibility check of the measuring results.

Each device includes a serial number and the guarantee stamp. If those are broken, no claims for guarantee can be made. In case of a faulty device, please contact Electromatic.

16.0 TECHNICAL DATA

Resolution of the display	0,1% water content 0,5°C temperature
Measuring range	8 to 30 % (60%)
Operation temperature	0°C to 40°C
Temperature measuring range	-20°C to 120°C (only measuring head)
Storage temperature	-20°C to 60°C
Temperature compensation	automatically
Power supply	4 pcs. 1,5 Volt AA Alkaline batteries (for approx. 1000 measurements)
Auto Switch Off	after approx. 6 minutes
Current consumption	55 mA (with light)
Display	128 x 64 matrix display, lighted
Dimensions	740 x 65 x 40 mm
Weight	approx. 450g (incl. batteries)
Degree of protection	IP 40
Scope of supply	MCT-HS-PRO, wooden case Software LogMemorizer USB cable 4 x 1,5Volt AA Alkaline batteries Compression plate

13.0 CHANGING BATTERIES

If the batteries are empty, please change them as follows:

- 1 Press with your finger onto the arrow of the battery cap and pull it back.
2. Remove the empty batteries.
3. Put four new 1.5 Volt AA Alkaline batteries into the device. Make sure that the position of the battery poles is correct.
4. Press down the batteries and close the cap.



If the battery symbol appears in the measuring window resp. if a critical charge of battery is shown in the status, the batteries have to be changed IMMEDIATELY. If you do not use your MCT-HS-PRO device for a longer period, remove the batteries. For eventual resulting damages we cannot provide any warranty.

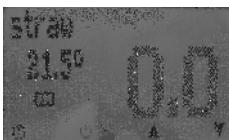

14.0 DETERMINATION OF THE MATERIAL REFERENCE MOISTURE

The MCT-HS-PRO determines the water content, that means that it calculates the moisture referred to the total mass:

$$\%F = \frac{M_n - M_t}{M_n} \times 100$$

M_n :	Mass with average moisture content
M_t :	Mass of the dried sample
%F:	Calculated absolute moisture (water content) (according to norm: CEN/TS 14774)

9.0 CHANGING THE USER LEVEL

Changing from advanced user to single user:

Make sure that you have activated the “super user” functions according to the instructions above. Afterwards change to the menu and choose „Options“.

In the submenu please select „o Userlevel“ (2 times \updownarrow - Options – o Userlevel)

Confirm by pressing the \leftarrow button. Now the single user is activated.

Changing from single user to advanced user:

Keep both the buttons \blacktriangle and \blacktriangledown pressed directly after switching on the device. Your MCT-HS-PRO automatically starts the main menu. Activate the the “super user” functions according to the instructions above.

Navigate to “Options – o Userlevel” and confirm by pressing the \leftarrow button.

10.0 MEASURING VALUE OUT OF RANGE

If the measure value is blinking, the valid measuring range is exceeded (limits see section 1.0). In this case the accuracy will be decreasing.





11.0 TRANSFER SAVED DATA TO THE PC

To send your saved logs to the PC, connect the MCT-HS-PRO device to your PC using the USB cable that was delivered with your device. Carefully loose the protection cap on your MCT-HS-PRO and plug in the USB mini B connector. The bigger connector has to be connected to a USB slot on your PC. Start the LogMemorizer software on your PC and switch on your MCT-HS-PRO.

The data transfer can be started on your MCT-HS-PRO or on the software.

Starting the data transfer on the MCT-HS-PRO:

Press the  key until you reach the menu (see image on the right). Then choose „Send Logs“ and confirm by pressing the  key. Now choose „Manual Logs“ and confirm with  again. All saved logs will be sent to your PC.

Starting the data transfer on your PC:

Press the button „remote control“ in the LogMemorizer software. A drop-down menu with several options opens (see image below).

For transferring the data you can select „Import last manual log“ (the last saved measuring series is transferred) or „Import all manual logs“ (all saved logs are transferred).

If you click on one of these menu items, the transfer starts immediately.

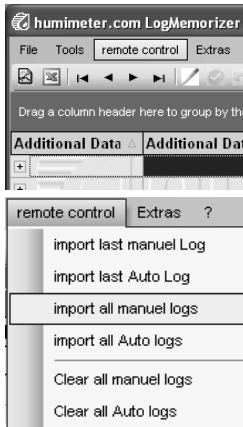
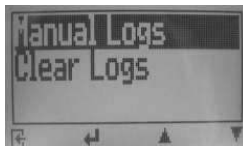

For the basic adjustments of the software please look through the instructions on the LogMemorizer CD.



12.0 PRINT SAVED DATA

To print your saved data, connect the device to the printer using the printer cable that was delivered with your device. Carefully loose the protection cap on the MCT-HS-PRO. At first plug in the side of the connector with the close plastic casing at the MCT-HS-PRO. Then switch on the device.

Not till then the other side of the cable has to be plugged in at the printer. Switch on the printer by pressing . Now the green LED is blinking. If it does not blink, please change the batteries and try again.

Press the  button at your MCT-HS-PRO until you reach the menu (see image on the right). Choose „Print Logs“ and confirm by pressing .

Now you can select if you want to print the last saved measuring series or all saved measuring series (logs).

Confirm by pressing  again. The selected logs are printed out now.

To save paper, please think of clearing the data storage regularly.

Online Print and Online Send

Your device supports the function “Online Print” and “Online Send”, this can be activated in the menu „Options“. If an option is active, every newly recorded log will immediately be printed or transferred to the PC after pressing  key.



MCT-HS-PRO

STRAW AND HAY MOISTURE METER

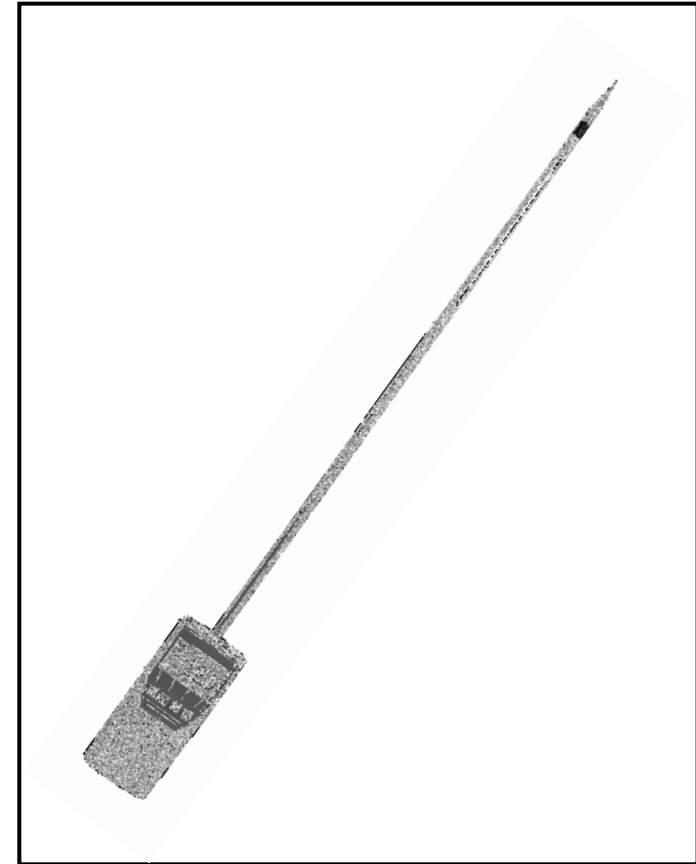

ELECTROMATIC
E Q U I P M E N T C O . I N C .

600 Oakland Ave., Cedarhurst, NY 11516-U.S.A.
TEL: 516-295-4300 • FAX: 516-295-4399