

Force Test Stands Series **TS**

MODELS TSA750, TSA750H,
TSB100, TSC1000 & TSC1000H

User's Guide

Thanks!

Thank you for purchasing a Mark-10 Series TS Force Measurement Test Stand. We are confident that you will get many years of service from this product.

Series TS Force Measurement Test Stands can be used in any number of compression and tension testing applications. To maintain smooth mechanical functioning of your test stand, avoid repetitive overloads and shock loads.

We hope that this User's Guide will provide a comprehensive explanation of the test stand's operation and sufficient detail on its specifications. However, if you have any questions or concerns our technical support and engineering teams will be eager to help you.

Thank you again for your purchase and happy testing!

TABLE OF CONTENTS

UNPACKING AND SETTING UP	3
LIST OF INCLUDED ITEMS.....	3
OPERATION, SPECIFICATIONS, AND DIMENSIONS.....	4
TSA750 / TSA750H.....	4
TSB100	6
TSC1000 / TSC1000H.....	8
WARRANTY	10

UNPACKING AND SETTING-UP

1. Carefully unpack the stand and inspect for any damage. Check to make sure that you have received a complete test stand with all accessories – see the “List of included items” section below.
2. Install the loading lever on Models TSA750, TSA750H and TSB100. The position of the loading lever can be adjusted as required – see the “Operation” section for your particular model. No assembly is required for Models TSC1000 and TSC1000H.
3. Place the stand on a firm, flat and level working surface free from vibration to ensure accurate readings. It is recommended that the test stand be secured to a work bench – see the “Operation” section for your particular model.

LIST OF INCLUDED ITEMS

Quantity	Item
1	Force measurement stand
4	#6-32 thumb screws for gauge mounting
4	#10-32 thumb screws (all models except TSB100)
1	User's guide CD
1	Mounting hole drill template (all models except TSA750H and TSC1000H)
1	Tool kit (all models except TSB100)
1	Attachment kit (all models except TSB100) - includes two hooks and a 2" diameter compression plate



TSA750 / TSA750H

OPERATION

1. Mount the test stand to a firm, flat, and level working surface for maximum safety and accuracy using four 5/16 screws (not included). Use the included mounting hole drill template to accurately drill the holes. Testing can take place without securing the test stand in such a manner, however, it is strongly recommended that the stand be secured, especially for large forces.
2. Install a force gauge onto the gauge plate with four thumb screws. Mark-10 force gauges mount directly to the stand without adapters.
3. Install any needed attachments, including grips, adapters, and other materials necessary for your test sample. Make sure these items are set up in a secure and safe manner.
4. Zero out the force gauge, then begin the test by turning the handwheel clockwise for compression or counter-clockwise for tension.

The loading lever can be adjusted to allow for ease of operation. Reposition the loading lever by removing the knob and realigning the lever pin in the mounting hub. Move the loading lever clockwise for compression, counter-clockwise for tension.

The rack brake can be set by loosening the wing nut, positioning the rack to the desired location and re-tightening the wing nut.

The clearance on the rack can be set by adjusting the four set screws using the tools provided.

The travel stops can be adjusted in 0.5" [12.7 mm] increments along the rack by moving the blocks to the desired location and tightening two screws. Fine adjustments can be made using adjusting screws on the housing and locking the jam nuts.

Note: To maintain smooth functioning of the stand, avoid overloads and repetitive shock loads.

Optional Equipment

Digital Travel Display Kit – for accurate position indication

This position indicator covers 6" of travel per setting with a 5-digit display (0.0005" resolution) and a computer interface for automated data collection. It may be easily installed by the user.

TSA750 / TSA750H

DIMENSIONS in [mm]

TSA750

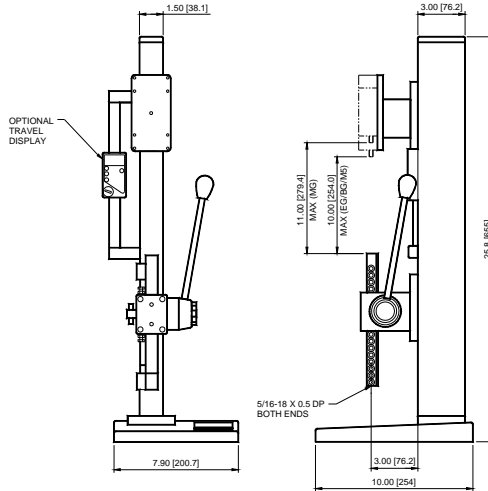

TSA750H

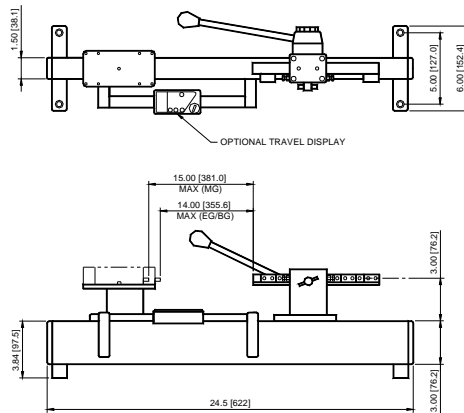

SPECIFICATIONS

Load capacity	750 lb [3750 N]
Maximum travel	6" / 3.75" [152.4 mm / 95.3 mm], with stops
Loading method / rate	Rack & pinion / 3" [76.2 mm] per rev.
Weight (test stand, only)	TSA750: 16 lb [7.3 kg], TSA750H: 13 lb [5.9 kg]
Optional digital travel display resolution	0.0005" [0.01 mm]

TSB100

OPERATION

1. Mount the test stand to a firm, flat, and level working surface for maximum safety and accuracy using four 5/16 screws (not included). Use the included mounting hole drill template to accurately drill the holes. Testing can take place without securing the test stand in such a manner, however, it is recommended that the stand be secured.
2. Install a force gauge onto the gauge plate with four thumb screws. Mark-10 force gauges mount directly to the stand without adapters.
3. Install any needed attachments, including grips, adapters, and other materials necessary for your test sample. Make sure these items are set up in a secure and safe manner.
4. Zero out the force gauge, then begin the test by turning the hand wheel clockwise for compression or counter-clockwise for tension.

The loading lever can be adjusted to allow for ease of operation. Reposition the loading lever by removing the knob and realigning the lever pin in the mounting hub. Move the loading lever clockwise for compression, counter-clockwise for tension.

The rack brake can be set by loosening the wing nut, positioning the rack to the desired location and re-tightening the wing nut .

The clearance on the rack can be adjusted by removing the gauge plate, aligning the C-bracket holes with the set screws and adjusting as necessary.

Note: To maintain smooth functioning of the stand, avoid overloads and repetitive shock loads.

Optional Equipment

Digital Travel Display Kit – for accurate position indication

This position indicator covers 6" of travel per setting with a 5-digit display (0.0005" resolution) and a computer interface for automated data collection. It may be easily installed by the user.

TSB100

DIMENSIONS

in [mm]

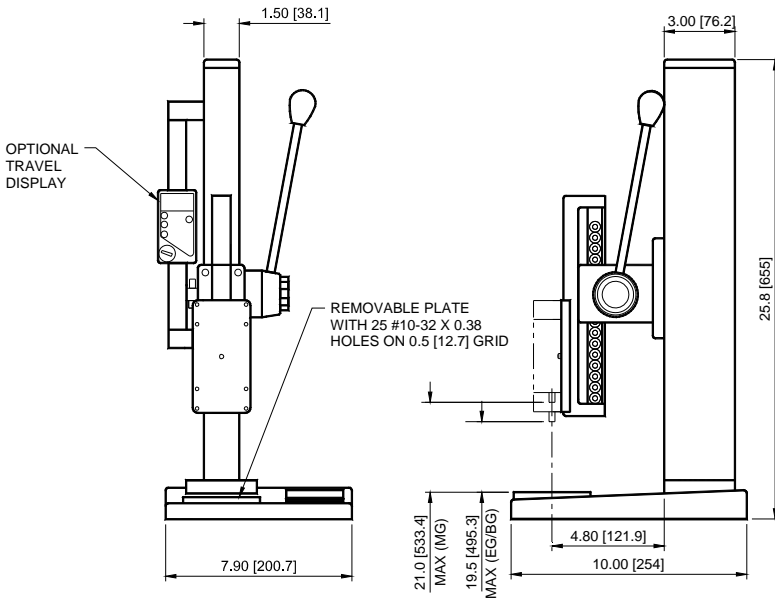

SPECIFICATIONS

Load capacity	100 lb [500 N]
Maximum travel	6" / 3.75" with stops [152.4 mm / 95.3 mm]
Loading method / rate	Rack & pinion 3" [76.2 mm] per rev.
Weight (test stand, only)	12 lb [5.4 kg]
Optional digital travel display resolution	0.0005" [0.01 mm]

TSC1000 / TSC1000H

OPERATION

1. Mount the test stand to a firm, flat, and level working surface for maximum safety and accuracy using four 5/16 screws (not included). Use the included mounting hole drill template to accurately drill the holes (TSC1000, only). Testing can take place without securing the test stand in such a manner, however, it is strongly recommended that the stand be secured, especially for large forces.
2. Install a force gauge onto the gauge plate with four thumb screws. Mark-10 force gauges mount directly to the stand without adapters.
3. Install any needed attachments, including grips, adapters, and other materials necessary for your test sample. Make sure these items are set up in a secure and safe manner.
4. Zero out the force gauge, then begin the test by turning the hand wheel clockwise for compression or counter-clockwise for tension.

Note: To maintain smooth functioning of the stand, avoid overloads and repetitive shock loads.

Optional Equipment

Digital Travel Display Kit – for accurate position indication

This position indicator covers 6" of travel per setting with a 5-digit display (0.0005" resolution) and a computer interface for automated data collection. It may be easily installed by the user.

SPECIFICATIONS

Load capacity	1000 lb [5000 N]
Maximum travel	3.5" [88.9 mm]
Loading method / rate	Handwheel 0.1" [2.54 mm] per rev.
Weight (test stand, only)	TSC1000: 25 lb [9.0 kg], TSC1000H: 20 lb [11.3 kg]
Digital travel display (optional)	Resolution: 0.0005" [0.01 mm]

TSC1000 / TSC1000H

DIMENSIONS

in [mm]

TSC1000

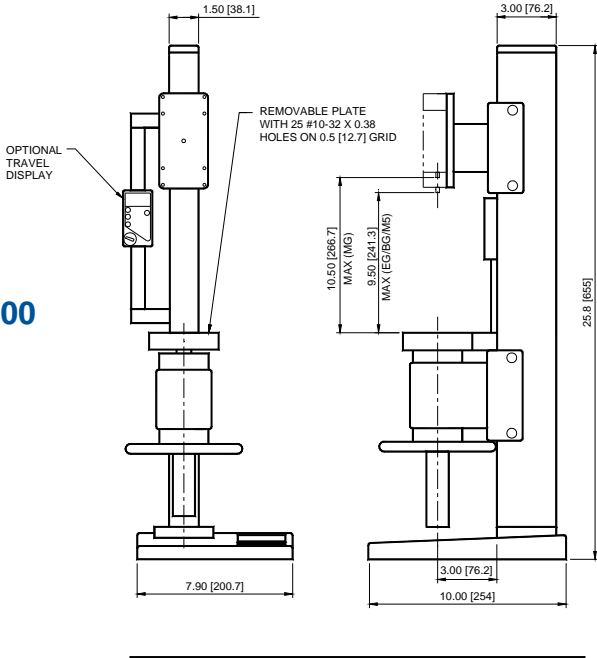

TSC1000H

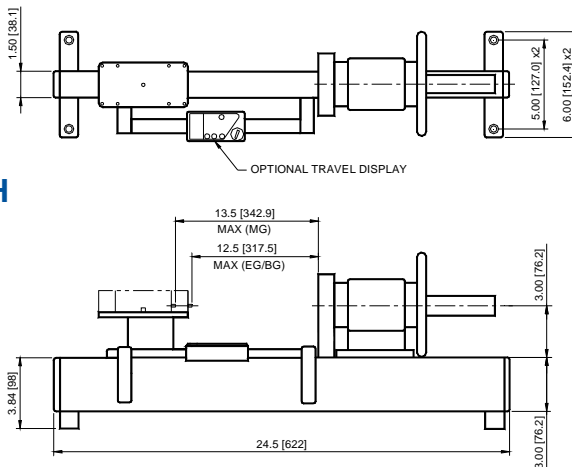

WARRANTY

Mark-10 Corporation expressly warrants to its buyer for three (3) years from the date of delivery that the goods sold are free from defects in workmanship and materials. Mark-10 Corporation will, at its option, repair or replace or refund the purchase price of goods found to be defective. This remedy shall be the buyer's sole and exclusive remedy. Any modification, abuse, exposure to corrosive environment or use other than intended will void this warranty. This warranty is in lieu of all other warranties, including implied warranties of merchantability and fitness for an intended purpose. In no event shall Mark-10 Corporation be liable for any incidental and consequential damages in connection with goods sold or any part thereof.