

Scale drawing

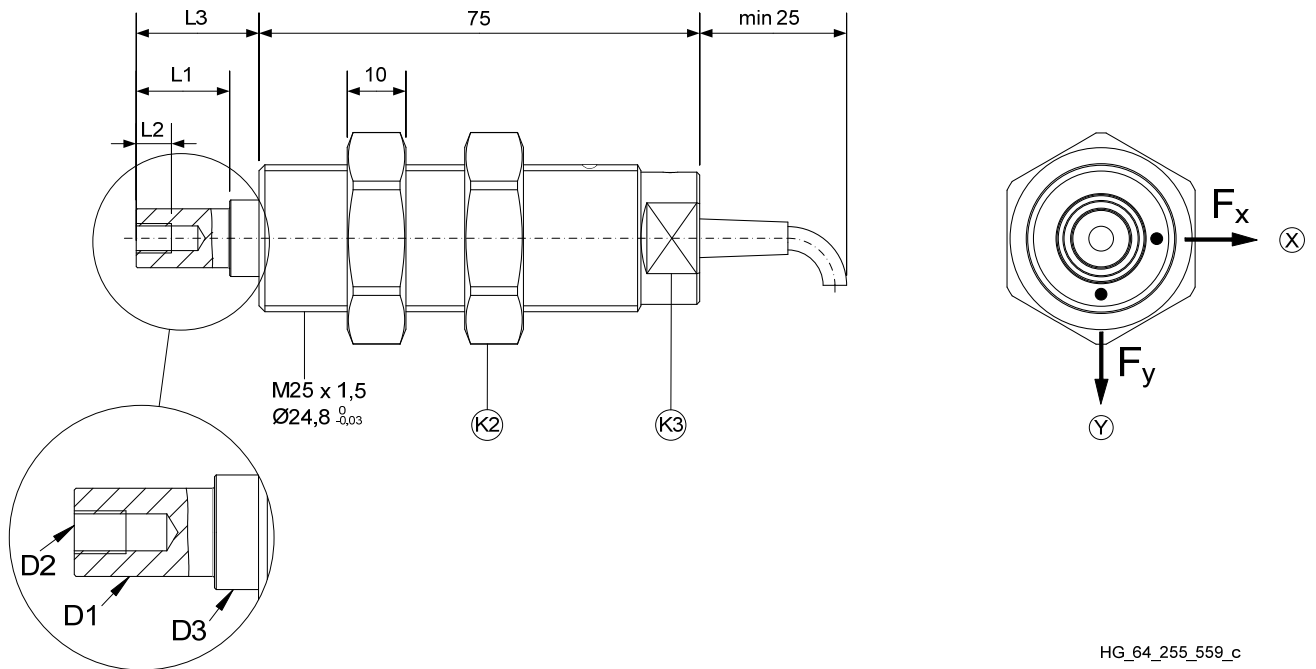

HG_64_255_559_c

All dimensions in mm

X: blue mark indicates the position of the measuring axis X

Y: red mark indicates the position of the measuring axis Y

Rated measuring ranges

Nominal force [N]						Bearing journal Ø [mm]			
5*	10	20	30	40		5	8	10	
50	60	100	200	300	400**		8	10	12
500**	600**	1000**						10	12

The measuring range of the sensor begins at the force's zero point.

Nominal forces differing from the list are available.

* Special type LR (Low Range)

** Special type HR (High Range)

Dimensions

Bearing journal Ø							
D1	L1	D2	L2	D3	L3	K2	K3
5	9,9	M3	6	7	12,9	WAF 32	WAF 19
8	11,9	M4	6	10	15,9	WAF 32	WAF 19
10	15,9	M5	8	13	20,9	WAF 32	WAF 19
12	19,9	M6	10	14	24,9	WAF 32	WAF 19

All dimensions in mm

WAF: width across flats

Non-standard dimensions and execution upon request

Technical data

Rated measuring ranges (F_N)	N	0 to 5...0 to 1000
Rated output	mV/V	1,0...1,5
Rated output tolerance	%	< $\pm 0,2$
Accuracy class		0,25
Excitation voltage max.	V	12
Reference excitation voltage	V	10
Input resistance	Ω	350 ± 3
Output resistance	Ω	350 ± 1
Isolation resistance	GΩ	> 10
Rated temperature range	$^{\circ}\text{C}$	-10 to 50, Option: -10 to 70
Operational temperature range		
- sensor	$^{\circ}\text{C}$	-10 to 70
- connection cable	$^{\circ}\text{C}$	-30 to 80
Storage temperature range	$^{\circ}\text{C}$	-30 to 70
Reference temperature	$^{\circ}\text{C}$	23
Temperature influence per 10 $^{\circ}\text{C}$		
- on the zero point	% F_N	< $\pm 0,1$
- on the calibration	% F_N	< $\pm 0,15$
Creep after 30 minutes	% F_N	< $\pm 0,05$
Linear output signal up to	% F_N	approx. 125
Mech. overload protection takes effect at	% F_N	approx. 140
Overload protected ^(#1)	% F_N	400...800 (depending on nominal force)
Deflection at nominal force	mm	0,07 $\pm 20\%$
Resonant frequency of the measuring cell	kHz	> 0,5 (depending on nominal force)
Weight	g	approx. 400
Protection class		IP 50
Sensor housing and nuts		stainless steel
Connection cable		3m long, flexible, shielded 8 x 0,14mm ² , total \varnothing 5,5mm

(#1) radial incoming force without additional bending or tilting moment

Connections

Measuring axis X			Measuring axis Y		
red	+U _{Br}	Excitation X	yellow	+U _{Br}	Excitation Y
blue	-U _{Br}		brown	-U _{Br}	
pink	+U _{Sig}	Output X	white	+U _{Sig}	Output Y
grey	-U _{Sig}		green	-U _{Sig}	

Shield (transparent or black) is not connected to sensor housing.

Order code

RFS 150 XY		- 400	- 10	- 3
Sensor type				
Nominal force [N]				
Bearing journal Ø [mm]				
Cable length [m]	Standard: 3 Option: required length			

Scope of supply

Sensor with protection cap

Options

- connection cable with male plug
- length of connection cable differing from standard
- seal gas protection
- special connection cable, e.g. oil-resistant or for use in Ex-protection areas

Special designs

- nominal forces differing from standard
- customized dimensions (housing / bearing journal)
- with turned-off threaded housing, to realize a gap ring at the bearing position
- advanced temperature range
- for measurement in vacuum

Accessories

- adapters for bearing journals
- for Ex-protection, e.g. Zener-barrier

Technical design subject to change without prior notice. © 2021 by Honigmann

Honigmann Industrielle Elektronik GmbH • In den Weiden 20 • D-58285 Gevelsberg • ☎ +49-2332-55115-0 • 📠 +49-2332-55115-99