

FGV-XY

Introducing the all new FGV-XY Force Gauge, now with USB Interface!

The all new FGV-XY series gauges feature rugged construction, ergonomic design and extensive features to provide a complete force testing instrument for a variety of industries. With free USB software and USB cable, the FGV-XY provides a total package for force testing up to 200lbs.



REVERSIBLE DISPLAY - EASY READING FOR HANDHELD OR TEST STAND MOUNTING

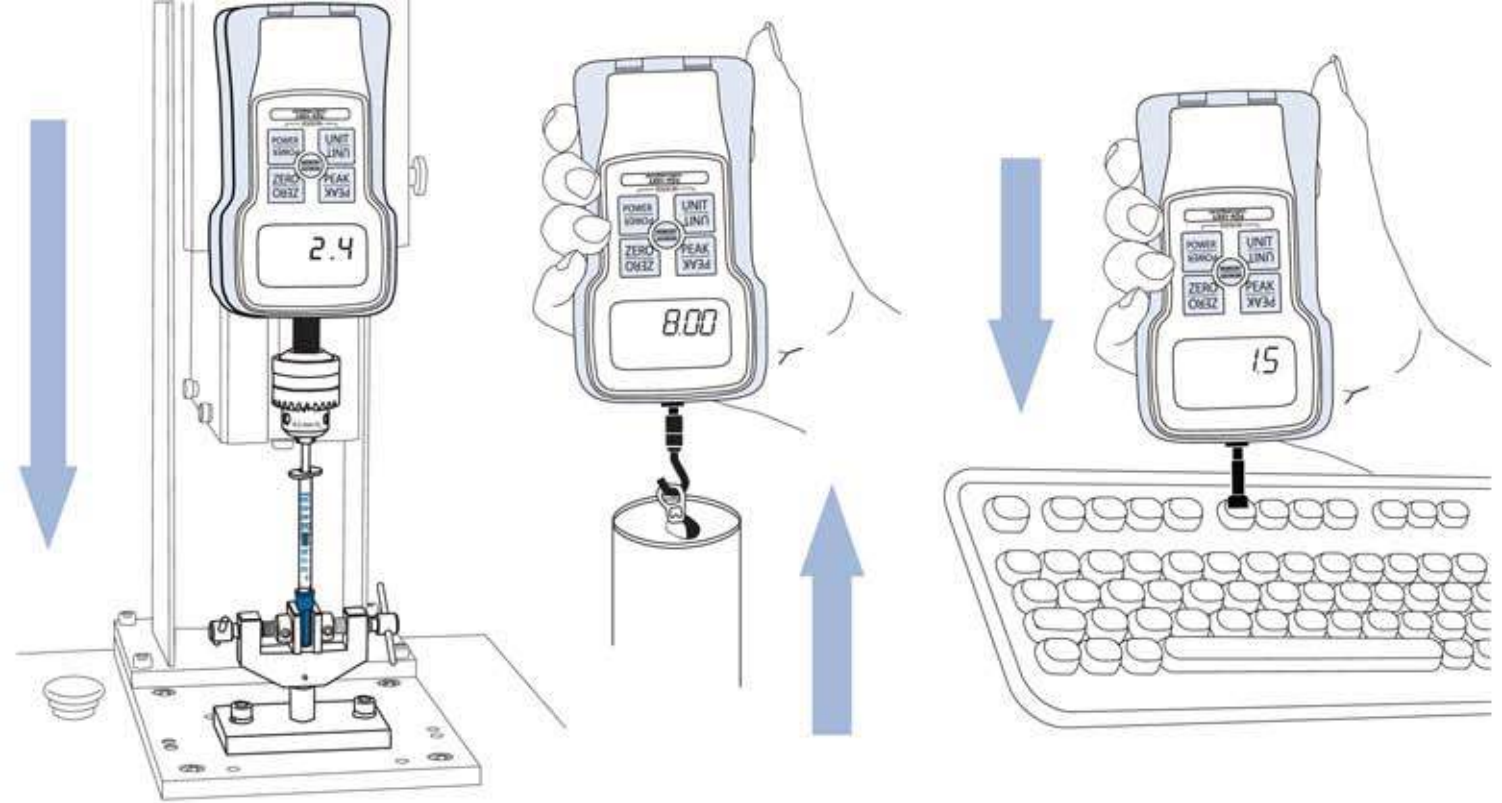

The ergonomically designed FGV-XY provides an easy to use force gauge for incoming quality inspection, finished goods testing, R&D and other force-related applications. Onboard statistical calculations provide fast access to maximum, minimum, average and standard deviation data.

The USB port and 1,000 point memory allows for data exporting in real time or after testing is complete. In addition, the RS-232C and analog outputs provide the FGV-XY with maximum flexibility.

Examples: Wallboard, wire pull, wire crimps, trigger pull, brake pedal, aerospace ceramic, springs, food ripeness, corrugated paper strength, blister pack, medical component, muscle strength, ergonomic testing, adhesives, syringe plunger, needle sharpness and many more.

FEATURES	BENEFITS
1000 Hz Sample Rate	Faster sampling to provide more accurate results
High Accuracy (0.2%)	Ideal for strict tolerances
USB/RS-232/Analog Outputs	3 different outputs for data collection provides maximum flexibility
Reversible Keypad and Display	Use as a handheld gauge or mount upside down on a stand upside down reading not required
0.5 Lb to 200 Lb Capacities	Various capacities allow testing of different applications without forfeiting accuracy
200% Overload Capacity	Higher overload protection results in less repairs - Cheap to keep
Rugged Die Cast Aluminum Construction	Exceptional durability
Selectable Auto-Shut Off	Prolongs battery life, while allowing constant use when powered via AC adapter
Small Size	Ergonomic design provides comfort for hand held testing
On Board Statistics	Obtain immediate results and analysis of your tests
Expanded Memory	Store data points for later review and transfer to PC/Laptop
Built In Hi-Lo Comparator	Perform quick and easy 'Go-No Go' Testing

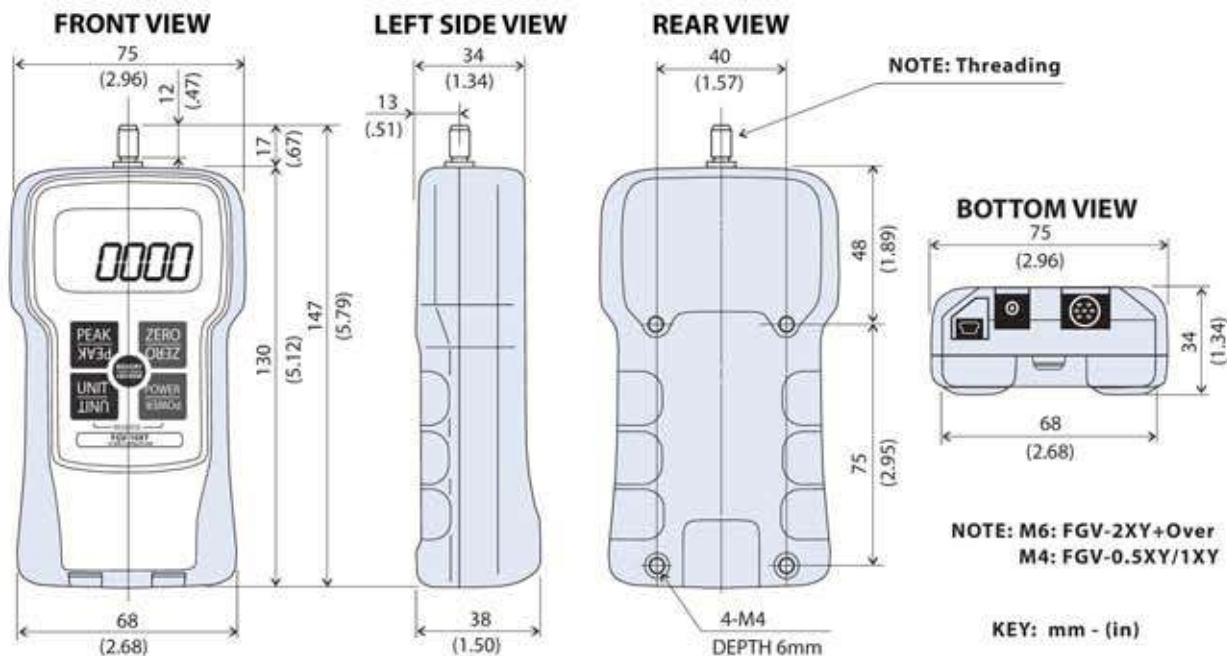

SPECIFICATIONS & DIMENSIONS

Mode	FGV-0.5XY	FGV-1XY	FGV-2XY	FGV-5XY	FGV-10XY	FGV-20XY	FGV-50XY	FGV-100XY	FGV-200XY
Capacity	0.5lb 2 N 200 g 8 oz	1 lb 5 N 500 g 16 oz	2 lb 10 N 1000 g	5 lb 20 N 2 kg	10 lb 5 N 5 kg	20 lb 100 N 10 kg	50 lb 200 N 20 kg	100 lbs 500 N 50 kg	200 lb 1000 N 100 kg
Resolution	0.001lb 0.001 N 0.1 kg 0.01 oz	0.001lb 0.01 N 1 kg	0.001lb 0.001 lb 0.01 N 0.001 kg	0.001 lb 0.01 N 0.001 kg	0.01 lb 0.01 N 0.001 kg	0.01 lb 0.1 N 0.01 kg	0.1 lb 0.1 N 0.01 kg	0.1 lb 1 N 0.1 kg	0.1 lb 1 N 0.1 kg
Units of Measure	lb / oz / g / N		lb / kg / N						
Measurement Modes	Standard, Compression Peak, Tension Peak								
Display Rate	User Selectable: 1, 2, 3, 5, 10, 20 times per second								
Sampling Rate	1000 times per second								
Accuracy	± 0.2% F.S.								
Influence of temperature	Gain : ± 0.01 LOAD / Zero : ± 0.01 / R.C. / Drift of zero point can be cancelled with tracking function.								
Display	Main display: 4-digits 12mm high, Reversible Units display: 3-digits 7mm high Other display: "LO BAT"(Low Battery Voltage), "BAT"(Battery Charging), "OVR"(Overload), "Peak"(Peak Hold)								
Overload	200% of Full Scale								150% F.S.
Tracking	User Selectable (ON/OFF)								
Output	USB	Allows communication between FGV-XY and Windows PC Software with ToriemonUSB via USB cable(included).							
	RS-232C	Allows communication between the FGV-XY and RS-232C devices. RS-232C cable is an optional accessory.							
	Analog	± 1V, Accuracy is ± 50mV through a 12 bit D/A. ZERO affects this output, and is updated at 1000 times/second. Load is >10k Ω							
	Overload/Comparator	Open-collector output (Max DC30V/5mA).							
Power	Rechargeable Nickel hydride battery or AC adapter/charger. Usable while charging. Operating Time: Approximately 8 hours after a full charge. Charging Time: 16 Hours Max.								
Auto Power Off	Default is 10 minutes. Can be disabled. Automatically disabled when connected to AC adapter.								
Memory function	Continuous memory: 1000 data points, Single memory: 100 data points, Standard memory: 50 data points Statistics functions (max minimum, peak, average, standard deviation)								
Comparator function	User Selectable: HI and LO								
Temperature range	0 - 40° C (-32 - 104° F)								
Humidity range	35 - 85% RH								
Dimensions	147mm (L)x 75mm (W) x 38mm(H)								
Weight	Approx. 450g								Approx. 500g
Accessories (Included)	AC adapter/charger, carrying case, hook, chisel, flat head, notched head, hanger, cone head, thread Adapter, extension rod, USB cable								
Application software	Application software (USB version): Available at www.shimpoint.com/software for free.								

FGV-XY DART 2.0 KIT WITH STANDARD ACCESSORIES INCLUDED



FGV-XY 2.0 Kit with Standard Accessories



FGV-XY 2.0 Manual



FGV-XY



AC Adapter

USB Cable



Flat Head



Thread Adapter



Chisel



Cone Head



Notched Head



Hook



Hanger



Extension Rod