

— WARNING —

1. Test samples can break or shatter, wear eye and body protection to avoid injury.
2. Do not exceed 500 lbf capacity. Be sure to set the upper and lower travel limits to avoid overload.
3. To reset from an overload see page 7.

2 YEAR WARRANTY (restrictions apply)

Imada, Inc. warrants its products to the original purchaser to be free from defects in workmanship and material under normal use and proper maintenance for two years (one year for adapters, attachments and cables) from original purchase. This warranty shall not be effective if the product has been subject to overload, shock load, misuse, negligence, accident or repairs attempted by others than Imada, Inc.

During the warranty period, we will, at our option, either repair or replace defective products. Please call our customer service department for a return authorization number and return the defective product to us with freight prepaid.

The foregoing warranty constitutes the SOLE AND EXCLUSIVE WARRANTY, and we hereby disclaim all other warranties, express, statutory or implied, applicable to the products and/or software, including but not limited to all implied warranties of merchantability, fitness, non-infringement, results, accuracy, security and freedom from computer virus. In no event shall Imada, Inc. and/or its affiliated companies be liable for any incidental, consequential or punitive damages in connection with the use of its products and/or software.

VERTICAL MOTORIZED TEST STAND Model MX-500

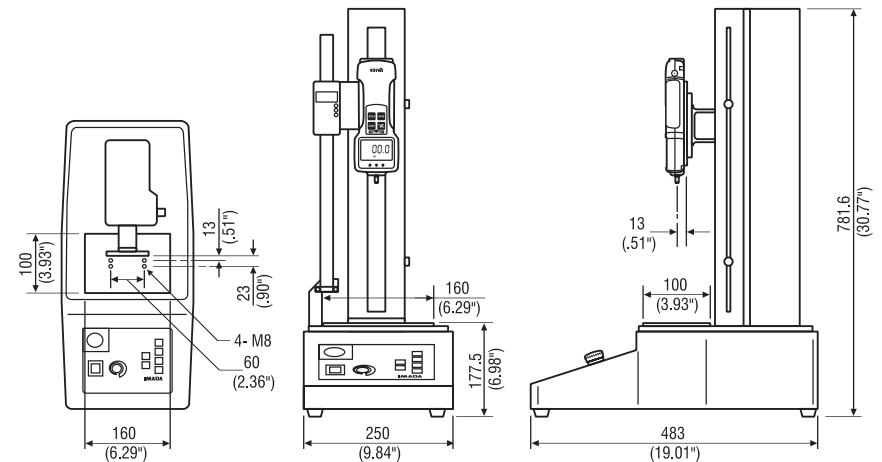

FORCE GAUGE AND DIGITAL DISTANCE METER SOLD SEPARATELY

INSTRUCTION MANUAL

INTRODUCTION

The Model MX-500 Vertical Motorized Test Stand assures consistent, identical measuring conditions by eliminating possible human error.

SPECIFICATIONS

Motorized Vertical Test Stand

Model No: MX-500

Max Load: 500 lbf

Speed: 0.2 – 7 in/min

Stroke: 13" (330 mm)

Power: 115/230 VAC

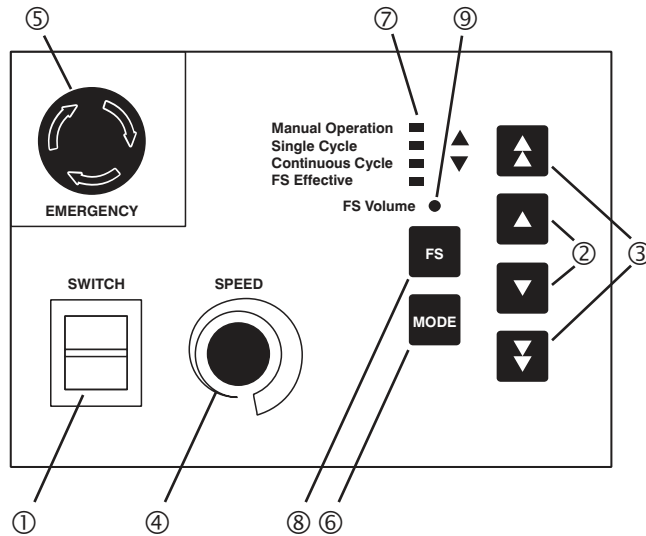

CONTROL PANEL

- | | |
|-------------------------------------|--------------------------|
| ① Power Switch | ⑤ Emergency Stop Switch |
| ② Adjustable Speed Direction Switch | ⑥ Mode Switch |
| ③ Maximum Speed Direction Switch | ⑦ Mode Indicators |
| ④ Speed Adjust Knob | ⑧ Fixed Speed Switch |
| | ⑨ Fixed Speed Adjustment |

RESET FROM OVERLOAD

If the test stand overloads or locks up during testing, disconnect the cable connecting the test stand to the force gauge, switch to Manual Operation and using a direction switch, back off the crosshead (in the opposite direction from the overload) to release the load.

TRAVEL LIMITS

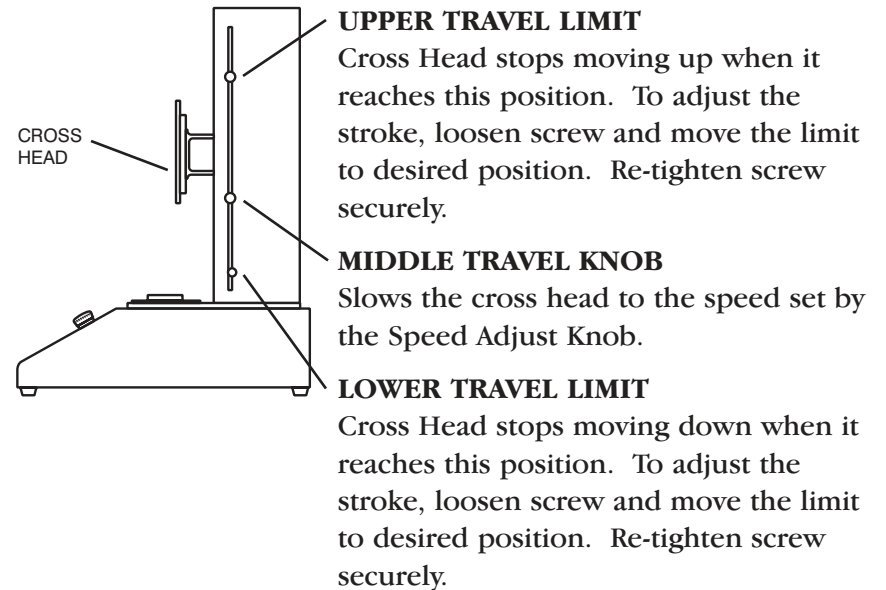

CAUTION:

Make sure to set the lower travel limit high enough to allow adequate clearance for the *force gauge and attachments*, so it will not be overloaded.

To prevent accidental movement of the lower limit position, replace the thumbscrew with an M5 Allen screw so that an Allen wrench will be required to adjust it.



3. Press **Mode Switch** ⑥ and select Continuous Cycle. *Press Mode switch again and the Continuous Cycle light ⑦ begins blinking.*

4. Select test speed:

A. Turn the **Speed Adjust Knob** ④ or

B. Press **Fixed Speed Switch** ⑧, the Mode Indicator ⑦ lights. (overrides Speed Adjust Knob). Fixed Speed can be adjusted by using a small screwdriver to adjust the **FS Volume** ⑨ potentiometer.

5. Press ZERO switch on Z2 or ZP gauge and start testing.

Single Preset One Way Force Control

Press the **Maximum Speed Direction Switch** ▲. The cross head moves (up or down) at maximum speed until the force value reaches the Low setpoint. The speed then changes to either the speed set by the **Speed Adjust Knob** ④ or the **Fixed Speed Switch** ⑧ if FS has been pressed. When the force value reaches the High setpoint programmed on the Z2 or ZP force gauge, the test stops.

High/Low Setpoints Force Control

Press the **Adjustable Speed Direction Switch** ▲. The cross head moves (up or down) at either the speed set by the **Speed Adjust Knob** ④ or the **Fixed Speed Switch** ⑧ if FS has been pressed. When the force value reaches the Low setpoint, force control is activated to maintain the force between the High and Low setpoints programmed on the Z2 or ZP force gauge.

To end force control, press a ▲ or ▼ direction switch or the **Emergency Switch** ⑤.

EMERGENCY BRAKE STOP SWITCH

Push the **Emergency Stop Switch** ⑤ whenever you are in an emergency situation. To re-engage the **Emergency Stop Switch**, simply turn the switch clockwise.



GENERAL OPERATION

Make sure of the following before plugging the power cord into the 115VAC output.

1. Turn **Speed Adjustment Knob** ④ to a middle position.
2. Turn the **Emergency Switch** ⑤ clockwise to make sure the Emergency Brake is re-engaged.
3. Move the upper and lower travel limits so that there is separation between them (see Page 7 of this manual).
4. Connect power cord to stand and plug into 115/230 VAC outlet.
5. Turn on Power Switch ①. The Orange power lamp will light.

MANUAL OPERATION

When the Power is turned on, startup mode is Manual Operation the appropriate Mode Indicator ⑦ will light. Manual Mode is for initial test position setup.

1. Press either ▲ **Adjustable Speed Direction Switch** to jog the cross head in that direction or press and hold, and the cross head moves until you release the switch. (The cross head speed is set by either the **Speed Adjust Knob** ④ or the **Fixed Speed Switch** ⑧).

Press either ▲ **Maximum Speed Direction Switch** to jog the cross head in that direction or press and hold, and the cross head moves at maximum speed until you release the switch.

2. Select speed

A. Turn the **Speed Adjust Knob** ④ or

B. Press **Fixed Speed Switch** ⑧, to override the **Speed Adjust Knob** (the Mode Indicator ⑦ lights). Fixed Speed can be adjusted by using a small screwdriver to adjust the **FS Volume** ⑨ potentiometer.

3. Regardless of the preset speed, when either **Maximum Speed Direction Switch** ▲ is pressed, the cross head moves at maximum speed.



SINGLE-CYCLE OPERATION

When the Power is turned on, startup mode is Manual Operation.

1. Press **Mode Switch** ⑥ and select Single Cycle, the Mode Indicator ⑦ lights.

2. Test Operation

Adjustable Speed Testing

Press either **Adjustable Speed Direction Switch** ▲ and the cross head moves (up or down) at the speed set by the **Speed Adjust Knob** ④. When the cross head reaches the lower or upper travel limit it stops, then returns to the opposite travel limit.

Fixed Speed Testing

Press the **Fixed Speed Switch** ⑧, the Mode Indicator ⑦ will light. Press either **Adjustable Speed Direction Switch** ▲ and the cross head moves (up or down) at the speed set by the **Fixed Speed Switch** ⑧. When the cross head reaches the lower or upper travel limit it stops, then returns to the opposite travel limit.

Maximum Speed Testing

Press either **Maximum Speed Direction Switch** ▲ and the cross head moves (up or down) at maximum speed. When the cross head reaches lower or upper travel limit it stops and then returns to the opposite travel limit.

CONTINUOUS CYCLE OPERATION

When the Power is turned on, startup mode is Manual Operation.

1. Press **Mode Switch** ⑥ and select Continuous Cycle, the Mode Indicator ⑦ lights.

2. Test Operation

Adjustable Speed Testing

Press either **Adjustable Speed Direction Switch** ▲ and the cross head moves (up or down) at the speed set by the **Speed**

Adjust Knob ④. When the cross head reaches the lower or upper travel limit it stops, then returns to the opposite travel limit. The cross head automatically repeats this cycle until a ▲ or ▲ direction switch or the Emergency Switch ⑤ is pressed.

Fixed Speed Testing

Press the **Fixed Speed Switch** ⑧, the Mode Indicator ⑦ will light. Press either **Adjustable Speed Direction Switch** ▲ and the cross head moves (up or down) at the speed set by the **Fixed Speed Switch** ⑧. When the cross head reaches the lower or upper travel limit it stops, then returns to the opposite travel limit. The cross head automatically repeats this cycle until a ▲ or ▲ direction switch or the Emergency Switch ⑤ is pressed.

Maximum Speed Testing

Press the **Maximum Speed Direction Switch** ▲ (up or down). The cross head moves (up or down) at maximum speed until it reaches the lower or upper travel limit and then stops and returns to the opposite travel limit. The cross head automatically repeats this cycle until a ▲ or ▲ direction switch or the Emergency Switch ⑤ is pressed.

FORCE CONTROL OPERATION

MX-500 test stand becomes a force control system when connected to an IMADA Z2 or ZP digital force gauge with a CB-501 interface cable. This feature may be used as overload protection and can help prevent overload damage in most cases, but due to the wide variety of testing conditions a guarantee is not possible.

1. Connect MX-500 test stand and IMADA Z2 or ZP force gauge with a CB-501 interface cable.
2. Program High and Low setpoints on IMADA Z2 or ZP force gauge. (Refer to Z2 or ZP Manual, Programming Setpoints section)