5.0 WARRANTY

ELECTROMATIC Equipment Co., Inc. (ELECTROMATIC) warrants to the original purchaser that this product is of merchantable quality and confirms in kind and quality with the descriptions and specifications thereof. Product failure or malfunction arising out of any defect in workmanship or material in the product existing at the time of delivery thereof which manifests itself within one year from the sale of such product, shall be remedied by repair or replacement of such product, at ELECTROMATIC's option, except where unauthorized repair, disassembly, tampering, abuse or misapplication has taken place, as determined by ELECTROMATIC. All returns for warranty or non-warranty repairs and/or replacement must be authorized by ELECTROMATIC, in advance, with all repacking and shipping expenses to the address below to be borne by the purchaser.

THE FOREGOING WARRANTY IS IN LIEU OF ALL OTHER WARRANTIES, EXPRESSED OR IMPLIED, INCLUDING BUT NOT LIMITED TO, THE WARRANTY OF MERCHANTABILITY AND FITNESS FOR ANY PARTICULAR PURPOSE OR APPLICATION. ELECTROMATIC SHALL NOT BE RESPONSIBLE NOR LIABLE FOR ANY CONSEQUENTIAL DAMAGE, OF ANY KIND OR NATURE, RESULTING FROM THE USE OF SUPPLIED EQUIPMENT, WHETHER SUCH DAMAGE OCCURS OR IS DISCOVERED BEFORE, UPON OR AFTER REPLACEMENT OR REPAIR, AND WHETHER OR NOT SUCH DAMAGE IS CAUSED BY MANUFACTURER'S OR SUPPLIER'S NEGLIGENCE WITHIN ONE YEAR FROM INVOICE DATE.

Some State jurisdictions or States do not allow the exclusion or limitation of incidental or consequential damages, so the above limitation may not apply to you. The duration of any implied warranty, including, without limitation, fitness for any particular purpose and merchantability with respect to this product, is limited to the duration of the foregoing warranty. Some states do not allow limitations on how long an implied warranty lasts but, notwithstanding, this warranty, in the absence of such limitations, shall extend for one year from the date of invoice.

ELECTROMATIC Equipment Co., Inc.
600 Oakland Ave. Cedarhurst, NY 11516—USA
Tel: 1-800-645-4330/ Tel: 516-295-4300/ Fax: 516-295-4399

Every precaution has been taken in the preparation of this manual. Electromatic Equipment Co., Inc., assumes no responsibility for errors or omissions. Neither is any liability assumed for damages resulting from the use of information contained herein. Any brand or product names mentioned herein are used for identification purposes only, and are trademarks or registered trademarks of their respective holders.

Table of Contents

1.0	Introduction	2
	1.1 Unpacking	
	1.2 Repacking and Storage	
2.0	Installation	3
	2.1 Mounting	
	2.2 Interconnections	
	2.3 Fuse	
	2.4 Main Chasis	
3.0	Internal Operations	5
	3.1 Controls	
	3.2 Internal Operation	
4.0	External Operations	6
5.0	Circuit Descriptions	7
	5.1 Normal (RUN) Operation	
6.0	Flashlamp Replacement	8
7.0	Specifications	9
8.0	Appendix: Modification for 230 VAC Operation	11
9.0	Warranty	12

1.0 INTRODUCTION

The AS4020, AS4060 and AS4200 Series Machine Vision Strobes provide short duration high intensity light pulses for industrial vision applications. The three models are identical, excluding the AS4200 which provides higher flash repetition rate at a lower output energy level than the AS4020 and AS4060. Refer to Specifications for details.

The AS4000 Series unit comes complete with an input power cable and connector, and an AS type Xenon Flashlamp. Each unit uses a NEMA Type 13 enclosure.

Light output is focused on a port configured to accept a fiber-optic cable. This allows light transmission to an area remote from the instrument. When coupled to a CCS/CID camera, the AS4000 Series strobe freezes motion, eliminating blur from the camera image and enhancing image quality

The AS4000 Series can be used for a variety of industrial robotics production applications including.

<i>Sorting</i>	<i>Color Differentiation</i>	<i>Part Recognition</i>
<i>Counting</i>	<i>Contaminant Detection</i>	<i>Motion Sensing</i>
<i>Label Reading</i>	<i>Component Orientation</i>	<i>Edge Detection</i>
<i>Motion Sensing</i>	<i>Package Integrity Verification</i>	<i>Web Printing Inspection</i>

ATTL input pulse from a camera unit is used to initiate the AS4000 Series flash
Operational power requirements are 115VAC or 230VAC, 50/60 Hz single phase power with a ground. Standard production units are factory set to either 115 VAC or 230 VAC.

1.1 Unpacking

The AS4000 Series strobe is shipped completely assembled in one container. Retain a and store all packing material for use during reshipment or return to the factory.

Examine the package for signs of damage or mishandling. Contact the carrier immediately if there are any signs of damage. DO NOT proceed with installation if there are any signs of damage or mishandling.



The Xenon Flashlamp is a high-pressure gas-filled device.
WARNING Wear safety glasses during handling

The Xenon Flashlamp is particularly vulnerable to rough treatment during shipping. After removing the AS4000 Series unit from the shipping container, raise the cover of the unit and observe the flashlamp mounted inside. Damage to the flashlamp should be immediately apparent.

1.2 Repacking and Storage

The AS4000 Series strobe needs to be placed in its original packaging for long periods of storage, when shipped to another location or returned to the factory for repair. If the original packing material is not available, the unit should be packaged in a container with sufficient protective material to ensure that the unit cannot move within the package and is protected from damage. Store in a dry area at a temperature of -10 °F to 194 °F (-40 °C to 90 °C).

8.0 APPENDIX A: MODIFICATION FOR 230 VAC OPERATION

The 230VAC version of the AS4000 Series strobe is available direct from the factory, so that user modification should not be required. However, in the event that conversion from 115VAC to 230VAC becomes necessary in the field, the user may perform the following:

Cut or Remove the jumper J1 in the upper left-hand corner of the AS3907 printed circuit board. Cutting J1 converts the system for 230VAC operation.

If a reverse conversion (230VAC to 115VAC) becomes necessary, return the unit to the factory. An attempt by the user to replace J1 will void the warranty and may result in damage to the unit.

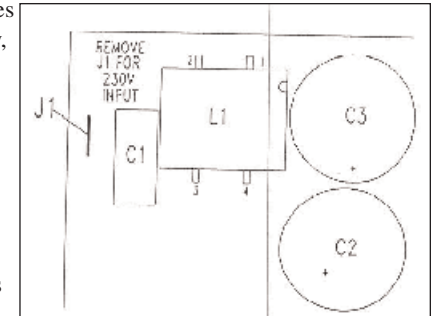

Light Output Waveform (based on 12 μF Capacitor)

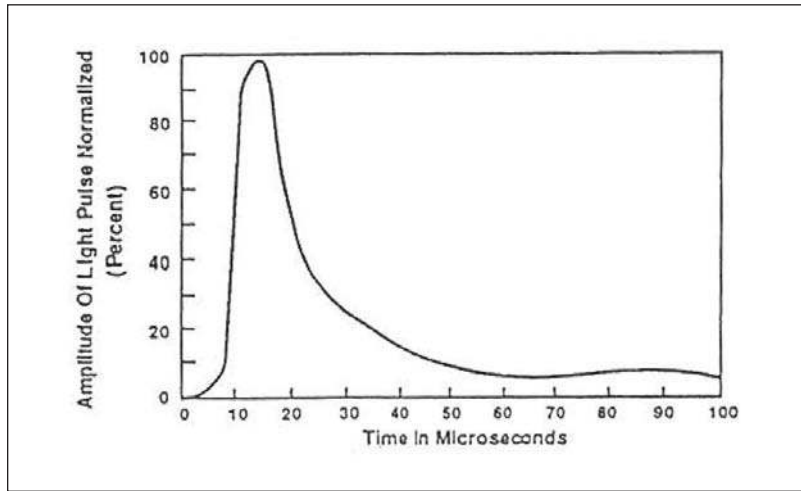

Spectral Distribution Of Light Pulse (based on 12 μF Capacitor)

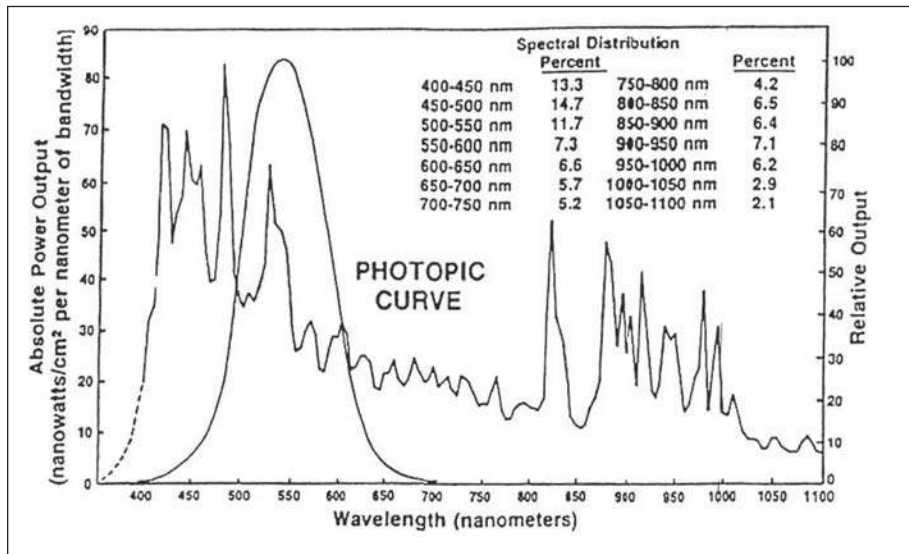

2.0 INSTALLATION

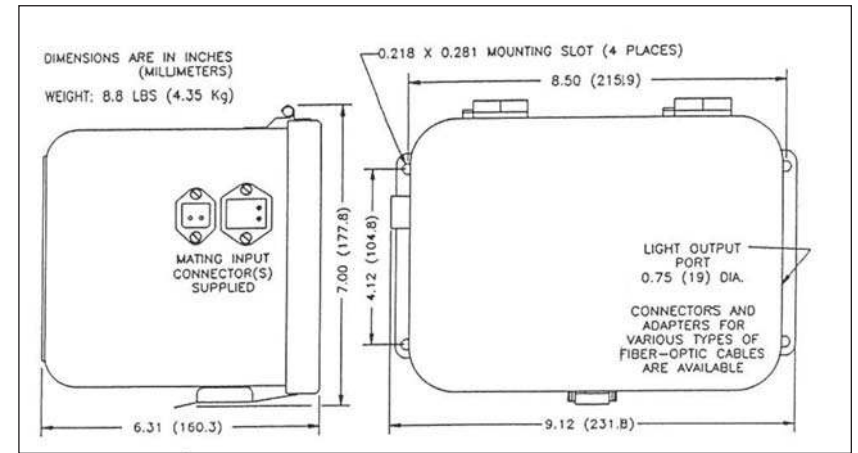

2.1 Mounting

Four holes in the base of the AS4000 Series unit provide for secure mounting in any position. Mounting hardware is not provided with the unit. Refer to Figure above.

2.2 Interconnections

Two connectors and a fuse are provided at the rear of the AS4000 Series enclosure. Refer to Figure.

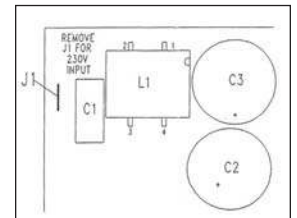

Power Connector: The input power cable (supplied) is connected to the smaller connector. Operating power is 115VAC or 230VAC (depending on the modification), 50/60 Hz single phase power with a ground.

Control Cable: A control cable (not supplied) is connected to the larger connector. The signal inputs are:

- Pin 1:** Trigger input—5V, 20mA pulse. Triggers on positive-going edge.
- Pin 2:** No connection.
- Pin 3:** Isolated input common for return of Pin 1 and Pin 5.
- Pin 4:** An external reference input signal voltage, 0 to 6V maximum or 1.7V minimum to keep lamp flashing.
- Pin 5:** Lamp failure signal output. This signal confirms the lamp has flashed as programmed. It is 12V high, with a width approximately the same as the light pulse (5 μS).
- Pin 6:** External reference return. Chassis ground.

CONNECTOR HARDWARE

Part No.	Type	Description
CN104	Power	Connector plug with strain relief, Hirschmann Type STAK 20 (Included on line cord)
CN103	Power	Connector plug for panel mounting, Hirschmann Type STASEI 2 (Included with unit)
CN106	Power	Security bracket, Hirschmann Type STASI 3 (Included with unit)
CN105	Control	Connector for cable mounting, Hirschmann Type Stak 5, 5+ ground signal connector (for cable) with six crimp contacts
CN102	Control	Connector plug for panel mounting, Hirschmann Type STASEI 5, 5+ ground connector (Included with unit)
CN100	Control	Security bracket, Hirschmann Type STASI 2 (Included with unit)

2.3 Fuse

A one amp fuse located on the NEMA enclosure provides AC line input protection.

2.4 Main Chassis

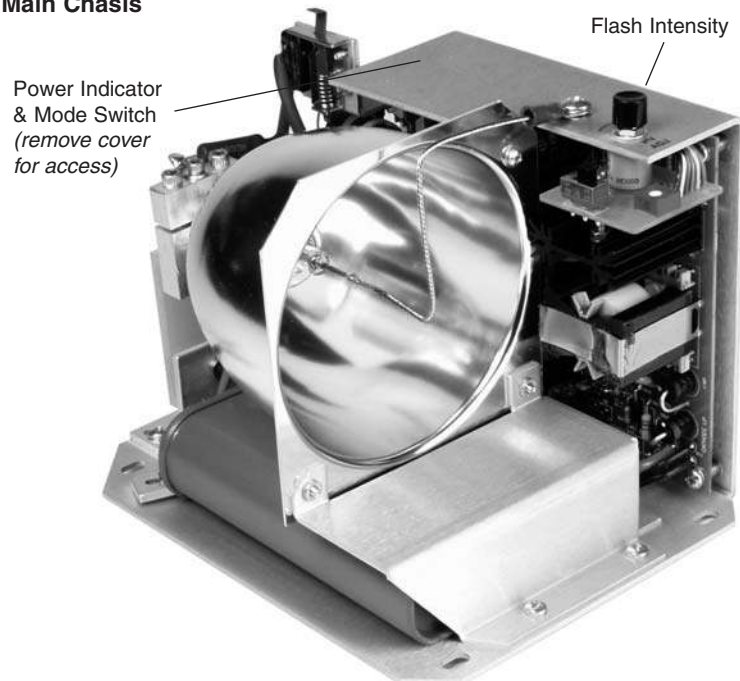

7.0 SPECIFICATIONS

Optical

Broadband light output	20 millijoules per flash at fiber-optic plane
Flash repetition rate	AS4020 - 20 flashes per second maximum AS4060 - 60 flashes per second maximum AS4200 - 200 flashes per second maximum
Input energy to flashlamp	AS4020 - 2.0 joules per flash maximum at 20 Hz AS4200 - 0.2 joules per flash maximum at 200 Hz
Light output pulse	Less than 25 μ S pulse width at all energy settings at 1/3 of peak energy
Lifetime of flash.lamp	100 million flashes while maintaining more than 70% of initial intensity (estimated)

Electrical

Power Line Requirement	115/230 VAC, 50/60 Hz
Power Consumption	0.5A maximum
Trigger Signal	+5V at 20mA (optically isolated)
Trigger Pulse Width	10 μ S (minimum)
Non-Synchronizing Time Before Pulse	200 μ S (minimum)
Turn-On Delay Command To Flash	10 μ S (Typical)

Environmental

Operating Temperature Range	-10 to 110 °F (-23 to +43 °C)
Storage Temperature Range	-40 to +194 °F (-40 to +90 °C)
Operating Altitude Range	Sea Level to 10,000 ft. (3,000 m)
Operating Humidity Range	0 to 90% noncondensing
Shock and Vibration	1.5g, 5 to 200 Hz, per MIL-STD-810C
Enclosure	NEMA Type 13; Confirms to JIC Std, EGP-1-1967 and European Std IEC 529, 1P65; Listed by Underwriters Laboratories, Inc.

6.0 FLASHLAMP REPLACEMENT

1. Disconnect power from unit.
2. Wait one minute to allow the lamp to cool and energy to capacitor to discharge.
3. Raise the cover.
4. Ground the rear lamp electrode holder using a screwdriver.
5. Loosen both socket head screws on lamp supporting bracket.
6. Remove lamp cathode ground screw.
7. Gently grasp the cathode ground wire and remove lamp.
8. To install a new lamp reverse the removal procedure,
9. The lamp is in the correct axial alignment when the rear electrode butts the back of the electrode holder.

Install a new lamp by reversing the removal procedure. Reconnect the anode wire to the trigger circuit. Secure the ground wire to the PC board.



WARNING

DANGER – The Xenon Flash lamp is a high-pressure, gas-filled device. Wear Safety glasses during handling

DANGER – HIGH VOLTAGE. Disconnect power cable and control cable before replacing Flashlamp.

CAUTION – During installation, do not apply torque to the lamp end seals.



3.0 INTERNAL OPERATIONS

3.1 Controls

In the AS4000 Series, a cover interlock switch automatically breaks the circuit whenever the unit is opened. This is to help protect the operator from danger of electric shock. To operate the unit while the cover is open, pull up on the interlock tab.

A test/run switch is provided for testing the unit in the absence of input signals. When the switch is in the **TEST** position, the unit is on and the lamp flashes at a fixed rate of 20 pps. For remote operation, the switch must be placed in the **RUN** position.

Light output intensity can be varied over a range of approximately 10:1 by means of an output control. A two-position slide switch is used to select either internal mode of control or external reference control from the input connector. Light output can be varied by means of the output control knob.

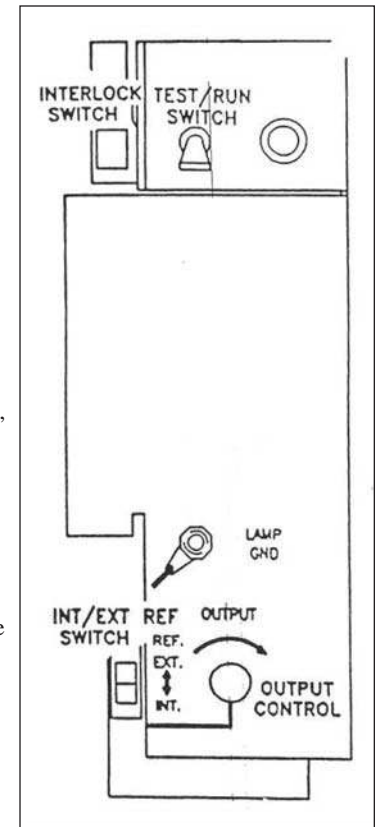

3.2 Internal Test & Operation

Check the AS4000 Series Strobe for proper operation using the following procedures (refer to figure above):

1. Disconnect power from unit
2. Lift the lid opening the enclosure
3. Visually inspect the flashlamp for damage
4. Place the TEST/RUN Switch in the **TEST** position
5. Reconnect power to the unit
6. Place the EXT/INT Reference Switch in the **INT REF** position
7. Lift the cover interlock switch to its up position



WARNING

Avoid looking directly at the high intensity light flash, either at the unit itself or at the end of the fiber-optic cable. This could result in damage to the eyes.

DANGER – HIGH VOLTAGE. Use extreme caution when operating the interlock switch, avoid contact with the front electrode of the flashlamp

-
-
8. The strobe should pulse at 20 pps.
 9. Allow the cover interlock switch to return to the **downward** position. This will cut off power to the unit.
 10. Turn the veristor HV ADJ control through its complete range, stopping at intervals to lift the cover interlock switch. Observe that light output variations occur over the total range of th HV ADJ control
 11. Return the TEST/RUN Switch to **RUN** position. Return the EXT/.INT Reference Switch to the **EXT REF** position.

4.0 EXTERNAL OPERATION

Operate the AS4000 Series Strobe in a production environment using the following procedure

1. Mount the AS4000 Series unit on a stable base in a location convenient to the production line to be viewed
2. Using option Nosepiece Adapter, connect a fiber-optic cable to the AS4000 Series light output port. Position the cable to distribute light to the desired area.
- 3 Lift the lid, opening the enclosure.
4. Place the TEST/RUN Switch in the RUN position.
5. Place the EXT/INT Reference Switch in the EXT/REF position
6. Close and secure the cover.
7. Connect power to the unit.
8. Connect a signal level input cable to the connector at the rear of the unit.
9. Connect the signal level input cable to a CCD/CID camera system that will provide TTL pulses to initiate flashes.

The system is now set to stop motion in the desired industrial vision application.

5.0 CIRCUIT DESCRIPTION

5.1 Normal Operation (RUN MODE)

The AS4000 Series strobe is made up of four functional circuit elements.

1. AS3906 Power Supply Board
2. AS3907 Voltage Control Board
3. AS3908 Add-On Board
4. Flashlamp storage capacitor and triggering circuit

A power cable supplied with the unit provides input power. A signal level input cable supplied by the customer provides operational support.

An energy storage capacitor stores energy provided by the AS3906 Power Supply Board. A trigger pulse discharges the capacitor into the flashlamp causing the lamp to flash.

The Power Supply Board recharges the energy storage capacitor during the interval between flashes.

During normal operation, the lamp will flash a maximum repetition rate of 60 when a trigger input pulse is applied between pins 1 and 3 of the signal input connector.

A transformer in the flashlamp circuit senses flashlamp current. Pins 3 and 5 of the signal input connector monitor the resulting signal. This signal is 12 volts high with a width approximately the same as the light pulse (5 μ S),

MACHINE VISION STOBOSCOPES
AS4000 SERIES



ELECTROMATIC
EQUIPMENT CO., INC.
600 Oakland Ave., Cedarhurst, NY 11516-U.S.A.
TEL: 516-295-4300 • FAX: 516-295-4399