

## 10.0 WARRANTY

ELECTROMATIC Equipment Co., Inc. (ELECTROMATIC) warrants to the original purchaser that this product is of merchantable quality and confirms in kind and quality with the descriptions and specifications thereof. Product failure or malfunction arising out of any defect in workmanship or material in the product existing at the time of delivery thereof which manifests itself within one year from the sale of such product, shall be remedied by repair or replacement of such product, at ELECTROMATIC's option, except where unauthorized repair, disassembly, tampering, abuse or misapplication has taken place, as determined by ELECTROMATIC. All returns for warranty or non-warranty repairs and/or replacement must be authorized by ELECTROMATIC, in advance, with all repacking and shipping expenses to the address below to be borne by the purchaser.

THE FOREGOING WARRANTY IS IN LIEU OF ALL OTHER WARRANTIES, EXPRESSED OR IMPLIED, INCLUDING BUT NOT LIMITED TO, THE WARRANTY OF MERCHANTABILITY AND FITNESS FOR ANY PARTICULAR PURPOSE OR APPLICATION. ELECTROMATIC SHALL NOT BE RESPONSIBLE NOR LIABLE FOR ANY CONSEQUENTIAL DAMAGE, OF ANY KIND OR NATURE, RESULTING FROM THE USE OF SUPPLIED EQUIPMENT, WHETHER SUCH DAMAGE OCCURS OR IS DISCOVERED BEFORE, UPON OR AFTER REPLACEMENT OR REPAIR, AND WHETHER OR NOT SUCH DAMAGE IS CAUSED BY MANUFACTURER'S OR SUPPLIER'S NEGLIGENCE WITHIN ONE YEAR FROM INVOICE DATE.

Some State jurisdictions or States do not allow the exclusion or limitation of incidental or consequential damages, so the above limitation may not apply to you. The duration of any implied warranty, including, without limitation, fitness for any particular purpose and merchantability with respect to this product, is limited to the duration of the foregoing warranty. Some states do not allow limitations on how long an implied warranty lasts but, notwithstanding, this warranty, in the absence of such limitations, shall extend for one year from the date of invoice.

ELECTROMATIC Equipment Co., Inc.  
600 Oakland Ave. Cedarhurst, NY 11516—USA  
Tel: 1-800-645-4330/ Tel: 516-295-4300/ Fax: 516-295-4399

Every precaution has been taken in the preparation of this manual. Electromatic Equipment Co., Inc., assumes no responsibility for errors or omissions. Neither is any liability assumed for damages resulting from the use of information contained herein. Any brand or product names mentioned herein are used for identification purposes only, and are trademarks or registered trademarks of their respective holders.

## TABLE OF CONTENTS

1.0	Introduction .....	2
2.0	Setup .....	2
3.0	Overview .....	3
4.0	Operation .....	4
	4.1 True RPM	
	4.2 Internal Triggering Mode	
	4.3 Synchronous Output Signal	
	4.4 FPM Display Mode	
	4.5 Deg m/sec Display Mode	
5.0	Changing Memory Parameters.....	7
6.0	Battery Management (DT-315A Only) .....	8
	6.1 Charging the Battery	
	6.2 Replacing the Battery	
7.0	Flash Tube Replacement .....	9
8.0	Specifications .....	10
9.0	Troubleshooting .....	11
10.0	Warranty .....	12



1. Do not look at the emitted light for long periods of time, it can be harmful to the eyes.
2. Do not disassemble or repair the unit while in operation.
3. Do not operate or store the instrument in the following places: explosive areas, areas near water, oil, dust or chemicals, or areas where the temperature is above 104°F (40 °C).

## 1.0 INTRODUCTION

Congratulations on your purchase of a Check•Line® DT-311A or DT-315A stroboscope/digital tachometer.

Please read the entire instruction manual thoroughly before initial set-up and operation; the information contained herein will aid you in operating your stroboscope safely and with excellent results.

If upon delivery shipping damage is detected, do not operate the unit. Notify the shipping carrier immediately for damage claim instructions. Refer to nameplate and record serial number for future reference.

### Items included with the DT-311A/DT-315A are:

- Handle
- Flash tube removing tool
- AC charger/adapter (Model 315A only)

### Optional Accessories:

- Carrying Case

## 2.0 SETUP

The DT-311A and DT-315A may be operated handheld or else mounted on a tripod for added convenience.

To mount the strobe on a tripod (or any other mounting surface), use screw 1/4 -20unc, length 8mm or shorter for the tripod screw hole on the bottom.

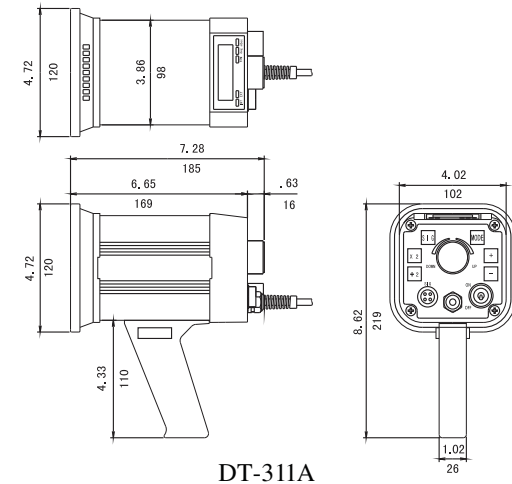

DT-311A

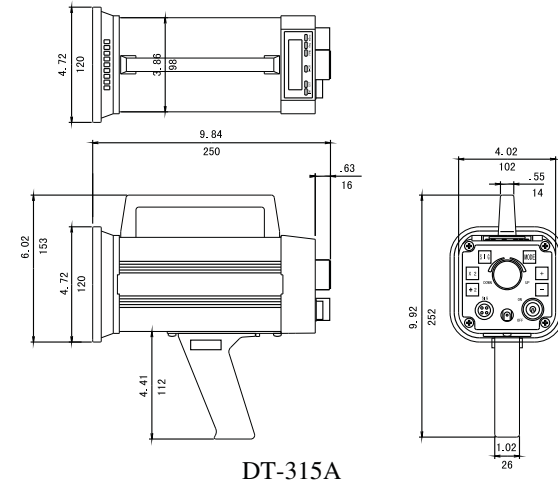

DT-315A

## 9.0 TROUBLESHOOTING

### FPM reading is displayed but unit is not flashing:

- Flash tube may need to be replaced.  
(see "Flash Tube Replacement" section).

### Stroboscope is in external trigger mode, no flash:

- Check flash tube. Replace if necessary.
- Check for damaged wiring and/or loose pin connections.

### Stroboscope is in internal trigger mode, no flash:

- Check flash tube. Replace if necessary.
- Check for damaged wiring and/or loose pin connections..

## 8.0 SPECIFICATIONS

### INTERNAL MODE

<b>Flashing Range</b>	40.0 - 35,000 FPM (flashes per minute)
<b>Accuracy</b>	±0.01% of reading
<b>Resolution</b>	0.1 FPM: 40.0 - 4,999.9 FPM 0.2 FPM: 5,000 - 7,999.8 FPM 0.5 FPM: 8,000 - 9,999.5 FPM 1 FPM: 10,000 - 35,000 FPM
<b>Phase Shift Use</b>	+/- push buttons (360° in 6 seconds)
<b>Display Update Time</b>	0.2 sec approx.
<b>Output Signal</b>	Synchronous, 400 µsec. Pulse output, 0 to +12 VDC amplitude(approx.), 4.7 K $\Omega$ impedance
<b>Rate Multiplier/Divider</b>	Multiply by 2, divide by 2

### EXTERNAL MODE

<b>Flashing Range</b>	0.0 - 35,000 FPM
<b>Accuracy</b>	±0.01% ±1 digit
<b>Phase Shift</b>	0 - 359° with 1° resolution
<b>Delay Time</b>	0 - 2,000 msec from 40 - 10,000 FPM
<b>External Trigger</b>	Input Signal LO level: 0 - 0.8 VDC, HI level: 2.5 - 12 VDC or open collector (NPN), pulse width 50 µsec min.
<b>Input Impedance</b>	4.7 K $\Omega$ at 12 V / 6.8 K $\Omega$ at 0 V

### GENERAL

<b>Display</b>	5 digits, 0.4" (10 mm) high, LED
<b>Flash Tube Power/Life</b>	Xenon, 10 W max. (100 million flashes)
<b>Flash Duration</b>	10 - 40 µsec
<b>Sensor Power Supply</b>	12 VDC (40 mA)
<b>Low Battery Indicator</b>	Display shows all L's
<b>Power Requirement</b>	
<b>DT-311A</b>	115 VAC or 220 VAC ±10% 60/50 Hz, 30 VA (specify voltage)
<b>DT-315A</b>	Internal Battery Pack
<b>Operating Temp. Range</b>	32° - 104°F ( 0 - 40°C )
<b>Weight</b>	
<b>DT-311A</b>	2.6 lb (1.2 kg)
<b>DT-315A</b>	4.4 lb (2 kg)
<b>Dimensions</b>	
<b>DT-311A</b>	7.28"L x 4.72"W x 4.72"H (185 x 120 x 120 mm)
<b>DT-315A</b>	9.84"L x 4.72"W x 4.72"H (250 x 120 x 120 mm)
<b>Warranty</b>	1 year
<b>Standard Accessories</b>	Handle, flash tube removal tool Handle, flash tube removal tool and AC charger/adaptor
<b>Optional Accessories</b>	Carrying case

## 3.0 OVERVIEW

- LED display:** Displays function and value
  - EXT:** External mode indicator
  - INT:** Internal mode indicator
  - B-CH:** Battery charge indicator (DT-315A only)
  - FPM:** Flash per minute indicator
  - deg:** Phase shift degree indicator
  - mSec:** Millisecond delay time indicator
  - Signal switch:** Switches the unit from the external mode to the internal mode (and vice-versa)
  - Display mode switch:** When unit is set to the external mode, the strobe will switch to RPM (FPM)/deg/msec each time "MODE" is depressed
- RPM (FPM)** Displays flashes per minute. External input 0-35,000 RPM (FPM)
- deg** Displays flash delay in degrees
- msec** Displays flash delay in msec
- Setter:** Changes the flashing rate
  - (x2) Switch:** In the internal mode, pressing "x2" doubles the flashing rate
  - (+) Switch:** In the internal mode, when object appears to be standing still, pressing "+" will give the illusion that the object is moving towards the rotating direction at a speed of 1 rotation in 6 seconds
  - (÷2) Switch:** In the internal mode, pressing "÷2" divides the flashing rate by two
  - (-) Switch:** In the internal mode, when object appears to be standing still, pressing "-" will give the illusion that the object is moving in reverse at a speed of 1 rotation in 6 seconds
  - Input and output connector:**  
PIN #1: +12V  
PIN #2: Synch output signal  
PIN #3: Input signal  
PIN #4: 0V
  - Power cord (DT-311A) / AC adapter (DT-315A)**
  - Power switch**

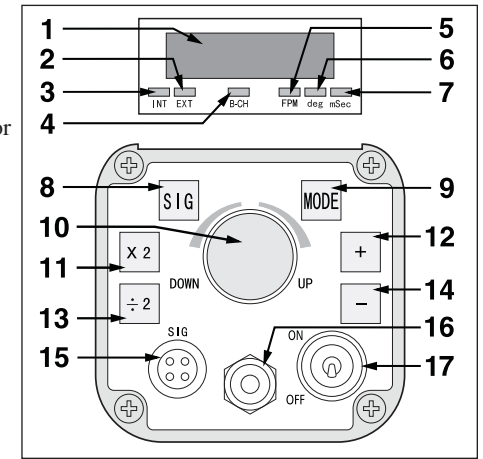

## 4.0 OPERATION

### 4.1 True RPM Measurement

DT311A/315A stroboscopes are DUAL function instruments that give the operator the illusion of “stopped motion” where in actuality the equipment under observation is in a moving state. By adjusting the flash rate, equipment in motion appears to be standing still. With a slight adjustment, movement can be viewed in apparent slow motion, which enables the operator or observer to study the process in action. All DT311A/315A stroboscopes can measure rotational (RPM) or reciprocating (strokes per minute) speeds with the same high precision as with an electronic digital tachometer.

To measure true revolutions per minute (RPM):

1. “Mark” the object to be measured by either visually noting an inherent distinguishing characteristic (such as a label, scratch, etc.) or physically marking the object with a small piece of tape, pencil mark, etc.
2. Firmly plug in power cord.
3. Turn power switch on.
4. Turn setter from highest FPM downward.
5. The true RPM can be noted once the action appears frozen and the first single image of the “mark” appears (see chart below and accompanying diagram for further explanation).
6. To verify RPM reading, press “÷2”; a single image should appear again.

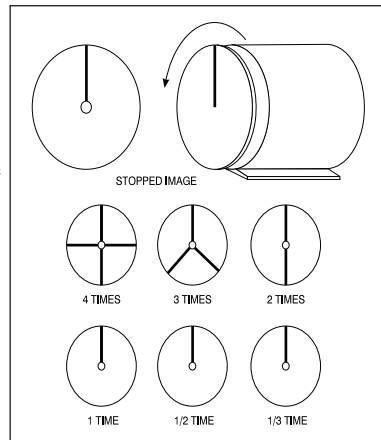

Rotation of shaft (rpm)	Number of flashes (rpm)	Flashes/ rpm shaft	Number of stopped images
at 1,500 rpm	6,000	4 times	4
	4,500	3 times	3
	3,000	2 times	2
	1,500	1 times	1
	750	1/2 times	1
	500	1/3 times	1

## 7.0 FLASH TUBE REPLACEMENT

When FPM reading is displayed but unit is not flashing, flash tube may need to be replaced:

1. Unplug line cord from power line (DT-315A).
2. Turn power switch off

**IMPORTANT:** Wait a few minutes until stroboscope is cool before replacing flash tube.

3. Remove protective window by removing the 4 screws.
4. Use tube removing tool provided: insert tool all the way and turn clockwise until tool locks. Pull out tube.
5. Install new flash tube using the removing tool.

**IMPORTANT:** Do not let the flash tube come in contact with bare skin, use a rag when handling.

**NOTE:** Make sure that the tube is placed vertically in the socket (see diagram below) otherwise it will touch the reflector. Tube should be set symmetrically within the neck of the reflector.

6. Replace protective window.
7. Mount reflector in the center so that the reflector will not interfere with the screw spacer on the corners.

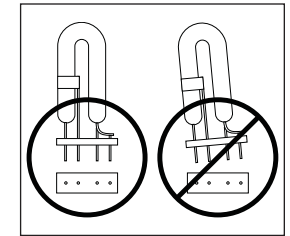

## 6.0 BATTERY MANAGEMENT (DT315A ONLY)

Model DT-315A is equipped with an internal rechargeable battery.

**NOTE:** Charge battery for approx. 15 hrs. before using the instrument for the first time.

### 6.1 Changing the battery

If battery is low, “LLLLL” is displayed and display will eventually disappear. Charge battery as follows:

1. Turn power off.
2. Insert AC adapter/charger plug into the strobe receptacle
3. B-CH lamp will be lit during battery charge; within 2 hours the battery should be charged completely.



AC adapter/charger receptacle

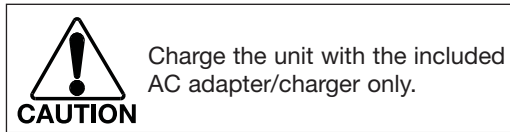

**NOTE:** The adapter/charger may be used as a power supply to power the strobe continuously.

### 6.2 Replacing the Battery

The life of the built-in battery should last for approximately 300 charges. If the time period between recharges becomes increasingly shorter, then replace battery with a new one.

## 4.2 Internal Triggering Mode

To operate the strobe in internal triggering mode:

1. Firmly plug in power cord (DT-311A only).
2. Turn power switch on.
3. If internal indicator is not on, press “SIG”; the INT light will then turn on.
4. Aim light beam at object under observation. The optimal distance between the strobe and moving object is approximately 2 feet.
5. Measure RPM by turning the setter to adjust the flashing rate to the rotational speed of the object.

**NOTE:** To achieve a particular rate quickly, use the “x2” or “÷2” switches and then the setter for fine tuning.

**NOTE:** Once the internal timer has expired, the strobe will stop flashing and the display will flash rapidly. To restart the strobe, turn power switch off, then on, and the cycle will repeat

## 4.3 External Triggering Mode

To operate the strobe in external triggering mode:

1. Connect external trigger or sensor wires according to connector pin designation:

- 1 +12V (for powering sensor)
- 2 Synch output signal
- 3 External input signal
- 4 0V (common)

2. Firmly plug in power cord.
3. Turn power switch on.
4. If INT lamp is on, press “SIG” until EXT lamp turns on.
5. Press “MODE” to select proper mode:

**FPM:** Light will flash in correspondence with input signal; the input signal will be calculated into FPM and displayed.

**deg** One cycle of input signal is 360°. A delayed angle will be displayed from 0 up to 359°. (The delayed angle can be changed by turning the knob setting as previously described).

**msec** The above delayed angle will be displayed in msec.

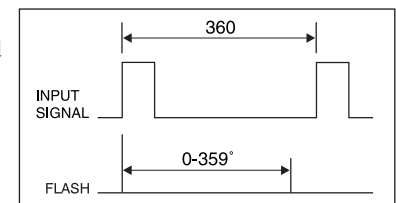

**NOTE:** If the input signal frequency exceeds upper or lower limits, the alarm dashes (----) will be displayed and the strobe will stop flashing.

**NOTE:** Once the internal timer has expired, the strobe will stop flashing and the display will flash rapidly. To restart the strobe, turn power switch off, then on, and the cycle will repeat.

#### 4.4 Synchronous Output Signal

For triggering and controlling additional stroboscopes, the synchronous output signal appears on pin #2 (see below).

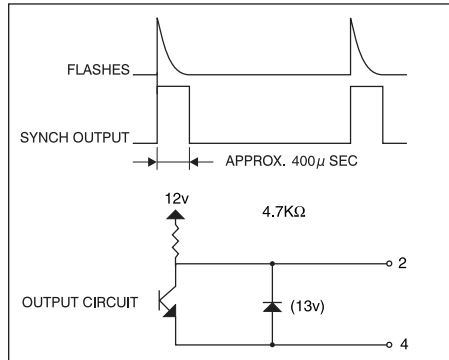

#### 4.5 FPM Display Mode

If the input signal exceeds 585Hz, the upper dashes on the digital display will be flashing:

---- upper dashes

If the input signal is lower than 0.67Hz, the lower dashes on the digital display will be flashing:

---- lower dashes

#### 4.6 Deg/msec Display Mode

If the input signal exceeds 167Hz, the upper dashes on the digital display will be flashing:

(deg) ---- upper dashes ---- (msec)

If the input signal is lower than 0.67Hz, the lower dashes on the digital display will be flashing:

(deg) ---- lower dashes ---- (msec)

If the input signal is lower than 0.67Hz, the lower dashes on the digital display will be flashing:

(deg) ---- lower dashes ---- (msec)

#### 5.0 CHANGING MEMORY PARAMETERS

The following parameters are set at the factory:

- Decimal point: autorange
- Internal timer: continuous
- External trigger edge: L-H (Lo to Hi)

These parameters can be changed in the field to facilitate different situations. To change any of the above parameters, follow these steps:

1. Turn power on.
2. Make sure that **INT** lamp is on. If not, press “**SIG**” until it turns on.
3. Change the desired memory parameter:

##### a. To change the decimal point:

- Press “÷2” and “-“ at the same time for approximately 2 seconds until display alternates between —1— and 0.0.
- Press “+”. The display will freeze and show 0.0.
- Change decimal point accordingly by pressing “+”. If 0.0 is selected the decimal point is in the autorange mode. If 0 is selected the decimal point is eliminated throughout the entire range.

##### b. To change the internal timer:

- Press MODE. The display will alternate between —2— and 0.
- Press “+”. The display will freeze to 0.
- Use the setter to set timer anywhere between 1 and 120 minutes.

---

## **Models DT-311A / DT-315A**

---

**DIGITAL TACHOMETER/STROBOSCOPE**

---



**ELECTROMATIC**  
EQUIPMENT CO., INC.  
600 Oakland Ave., Cedarhurst, NY 11516-U.S.A.  
TEL: 516-295-4300 • FAX: 516-295-4399

**Operating Instructions**