

2 YEAR WARRANTY (RESTRICTIONS APPLY)

Imada, Inc. warrants its products to the original purchaser to be free from defects in workmanship and material under normal use and proper maintenance for two years (one year for adapters, attachments, batteries, and cables) from original purchase. This warranty shall not be effective if the product has been subject to overload, shock load, misuse, negligence, accident or repairs attempted by others than Imada, Inc.

During the warranty period, we will, at our option, either repair or replace defective products. Please call our customer service department for a return authorization number and return the defective product to us with freight prepaid.

The foregoing warranty constitutes the **SOLE AND EXCLUSIVE WARRANTY**, and we hereby disclaim all other warranties, express, statutory or implied, applicable to the products and/or software, including but not limited to all implied warranties of merchantability, fitness, non-infringement, results, accuracy, security and freedom from computer virus. In no event shall Imada, Inc. and/or its affiliated companies be liable for any incidental, consequential or punitive damages in connection with the use of its products and/or software.

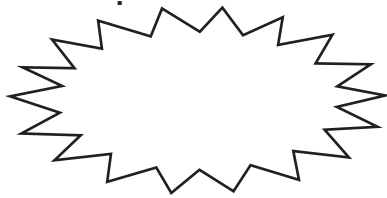

Specifications subject to change without notice.

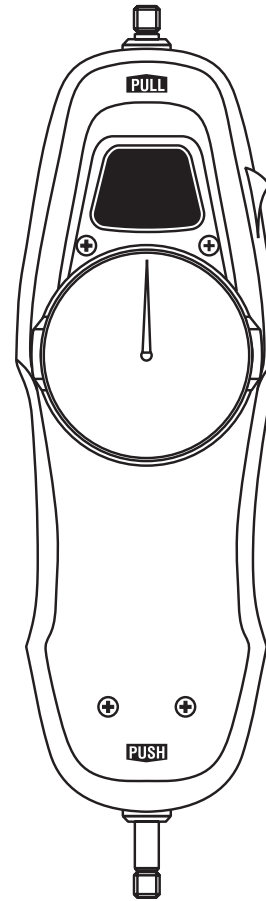

Model PS
Model MF
Model FB

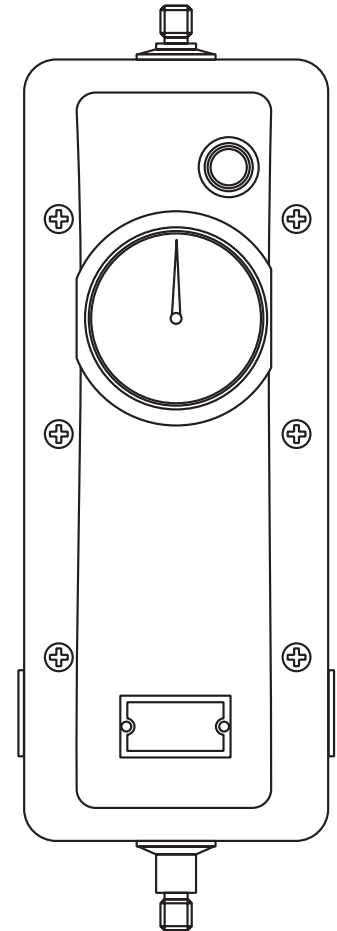

Model PSH
Model ESH

INSTRUCTION MANUAL

GENERAL OPERATION

1. Press (or rotate for Model PSH/ESH) Peak Switch OFF.
2. Hand tighten (no tool!) attachment to the measuring shaft.
3. Rotate Tare Ring to read "0" to tare the weight of attachment and measuring shaft orientation.
4. Begin measuring.

Real Time Mode: the Peak Switch is OFF and the gauge displays force as it changes. During Real Time Mode, you can hold a critical reading by turning the Peak Switch to the ON position.

Peak Mode: the Peak Switch is ON and the gauge will retain highest reading taken which will not change until a higher value is measured. Turn the Peak Switch OFF to zero the gauge and turn it ON again to measure Peak values.

MOUNTING

When mounting IMADA mechanical gauges to IMADA test stands, hold the gauge firmly and unscrew the 4 screws in back, making sure the case does not separate. (FIG. 1)

AP-002 adapter plate mounts IMADA mechanical gauges to IMADA test stands. Align plate and gauge holes and insert the 4 long screws supplied to attach gauge. Then utilize the 4 PEM nuts on the adapter plate to mount to IMADA test stands with the mounting bolts supplied.

AP-001 adapter plate mounts IMADA low capacity gauges to most other brands of test stands. Use the 4 screws (supplied) to mount the IMADA gauge to the AP-001 adapter plate. Then utilize the 2 PEM nuts on the AP-001 adapter plate to mount to other brands of test stand.

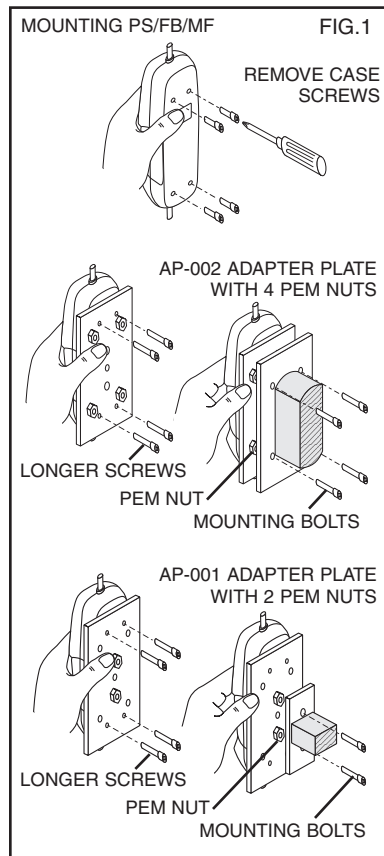

DIMENSIONS

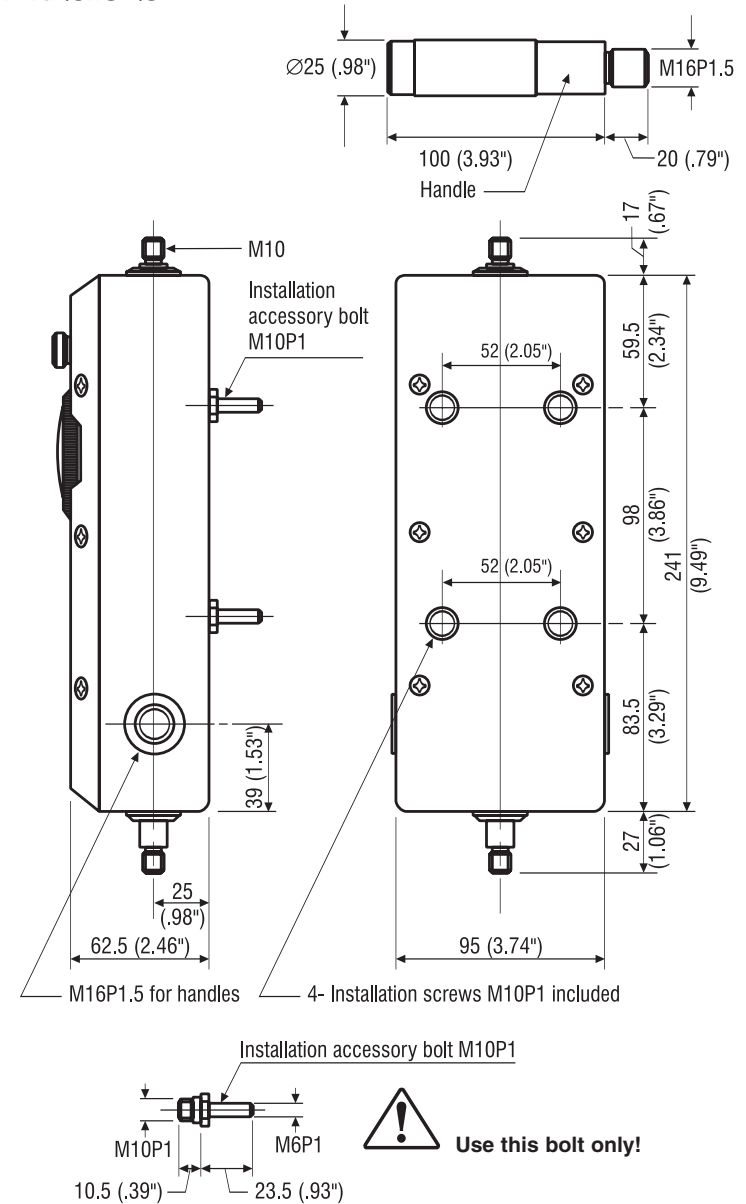

Specifications subject to change without notice.

DIMENSIONS

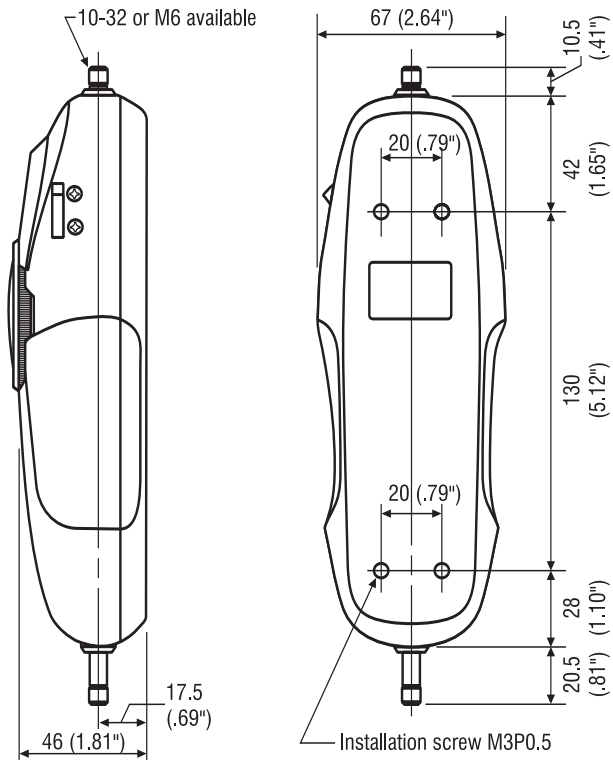

When installing be sure to keep the depth to 8mm

Specifications subject to change without notice.

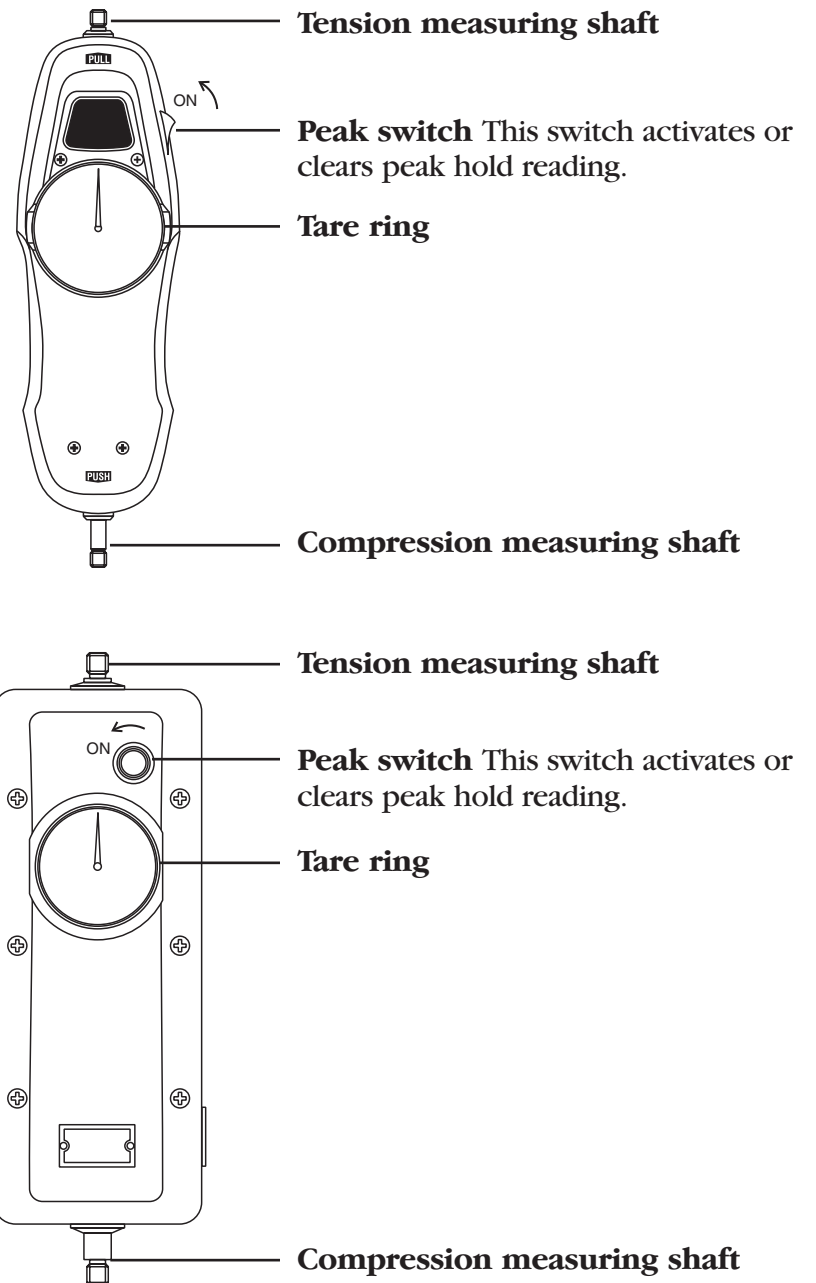

IMPORTANT

1. Do not exceed the capacity of the unit and avoid shock loading.
2. Failure to allow for sufficient overload capacity in the load, structure and mounting elements, may result in property damage, serious injury, and death. For applications involving suspension of equipment, additional safeguards are also a necessity.
3. Do not use the tension shaft to measure compression or the compression shaft to measure tension.
4. Accuracy may be affected if unit is exposed to high humidity or dust.
5. Do not apply oil or chemical soap, which causes corrosion or dust adhesion.
6. Do not remove warranty seal or disassemble gauge. Disassembly voids warranty.
7. Specifications subject to change without notice.

OPTIONAL HANDLE

The OH-1/MOH-1 fits PS, MF and FB series. Constructed of high quality steel for rugged use, the handle facilitates measurements of heavy loads. Complete with mounting screws, the OH-1 handle ensures safe and consistent measuring conditions.

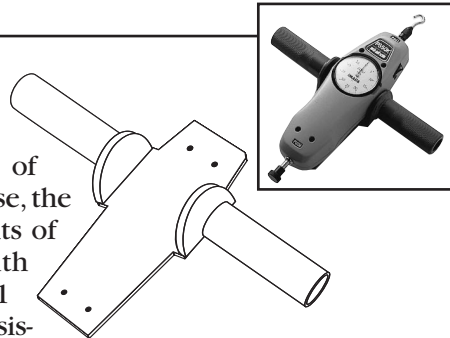

PS/MF Ranges (Resolution) Accuracy: PS±0.2% F.S. MF±0.3% F.S.

Pounds		Kilograms		Newtons	
Model	Capacity (Resolution)	Model	Capacity (Resolution)	Model	Capacity (Resolution)
PS-32oz	32ozf (0.25 ozf)	PS-0.5 kg	500 gf (2.5 gf)	PS-10 N	10 N (0.05 N)
PS-80oz	80ozf (1 ozf)	PS-1 kg	1 kgf (5 gf)	PS-20 N	20 N (0.1 N)
PS-2	2 lbf (0.01 lbf)	PS-2 kg	2 kgf (10 gf)	PS-30 N	30 N (0.2 N)
PS-5	5 lbf (0.025 lbf)	PS-3 kg	3 kgf (20 gf)	PS-50 N	50 N (0.25 N)
PS-10	10 lbf (0.05 lbf)	PS-5 kg	5 kgf (25 gf)	PS-100 N	100 N (0.5 N)
PS-20	20 lbf (0.1 lbf)	PS-10 kg	10 kgf (50 gf)	PS-200 N	200 N (1 N)
PS-30	30 lbf (0.2 lbf)	PS-20 kg	20 kgf (100 gf)	PS-300 N	300 N (2 N)
PS-50	50 lbf (0.25 lbf)	PS-30 kg	30 kgf (200 gf)	PS-500 N	500 N (2.5 N)
PS-100	100 lbf (0.5 lbf)	PS-50 kg	50 kgf (250 gf)		

Overload capacity: 165 lbs. for all ranges Stroke: 10 mm F.S.

FB Ranges (Resolution) Accuracy: FB ±0.3% F.S. FB-150 ±0.5%F.S.

Pounds		Kilograms		Newtons	
Model	Capacity (Resolution)	Model	Capacity (Resolution)	Model	Capacity (Resolution)
FB-32oz	32ozf (0.25 ozf)	FB-1 kg	1 kgf (10 gf)	FB-10 N	10 N (0.1 N)
FB-80oz	80ozf (1 ozf)	FB-2 kg	2 kgf (20 gf)	FB-20 N	20 N (0.2 N)
FB-2	2 lbf (0.02 lbf)	FB-3 kg	3 kgf (25 gf)	FB-30 N	30 N (0.25N)
FB-5	5 lbf (0.05 lbf)	FB-5 kg	5 kgf (50 gf)	FB-50 N	50 N (0.5 N)
FB-10	10 lbf (0.1 lbf)	FB-10 kg	10 kgf (100 gf)	FB-100 N	100 N (1 N)
FB-20	20 lbf (0.2 lbf)	FB-20 kg	20 kgf (200 gf)	FB-200 N	200 N (2 N)
FB-30	30 lbf (0.25 lbf)	FB-30 kg	30 kgf (250 gf)	FB-300 N	300 N (2.5 N)
FB-50	50 lbf (0.5 lbf)	FB-50 kg	50 kgf (500 gf)	FB 500 N	500 N (5 N)
FB-100	100 lbf (1 lbf)				
FB-150	150 lbf (1 lbf)				

Overload capacity: 165 lbs. for all ranges Stroke: 10mm F.S.

ESH and PSH Ranges (Resolution) Accuracy: ESH±0.5% F.S. PSH±0.3% F.S.

Pounds		Kilograms		Newtons	
Model	Capacity (Resolution)	Model	Capacity (Resolution)	Model	Capacity (Resolution)
ESH-200	200 lbf (2 lbf)	ESH-50 kg	50 kgf (0.5 kgf)		
PSH-200	200 lbf (1 lbf)	PSH-50 kg	50 kgf (0.25 kgf)		
ESH-300	300 lbf (2.5 lbf)	ESH-100 kg	100 kgf (1 kgf)	ESH-1000 N	1000 N (10 N)
PSH-300	300 lbf (2 lbf)	PSH-100 kg	100 kgf (0.5 kgf)	PSH-1000 N	1000 N (5 N)
ESH-400	400 lbf (4 lbf)	ESH-200 kg	200 kgf (2 kgf)	ESH-2000 N	2000 N (20 N)
PSH-400	400 lbf (2 lbf)	PSH-200 kg	200 kgf (1 kgf)	PSH-2000 N	2000 N (10 N)
ESH-500	500 lbf (5 lbf)	ESH-300 kg	300 kgf (2.5 kgf)	ESH-3000 N	3000 N (25 N)
PSH-500	500 lbf (2.5 lbf)	PSH-300 kg	300 kgf (2 kgf)	PSH-3000 N	3000 N (20 N)

Overload capacity: 135% of rated capacity Stroke: 10mm F.S.